



www.samenacouncil.org

SAMENA TRENDS

FOR SAMENA TELECOMMUNICATIONS COUNCIL'S MEMBERS

BUILDING DIGITAL ECONOMIES



Featured

Olayan M. Alwetaid
CEO
stc Group

THIS MONTH

SUSTAINABLE ICT DEVELOPMENT & DIGITAL ENABLEMENT

SAMENA TRENDS

Editor-in-Chief
Bocar A. BA

Contributing Editors
Izhar Ahmad
Javaid Akhtar Malik

Knowledge Contributions
Avaya
Kearney
Syniverse
Tech Mahindra

Publisher
SAMENA Telecommunications Council

Subscriptions
subscriptions@samencouncil.org

Advertising
ads@samencouncil.org

SAMENA TRENDS
trends@samencouncil.org
Tel: +971.4.364.2700



The SAMENA TRENDS eMagazine is wholly owned and operated by the SAMENA Telecommunications Council (SAMENA Council). Information in the TRENDS is not intended to serve as a professional services advice. Articles and information contained in this publication are the property of SAMENA Council (unless otherwise noted, described or stated) and cannot be reproduced, copied or printed in any form without the express written permission of the publisher.

DISCLAIMER: The SAMENA Council also does not necessarily endorse, support, sanction, encourage, verify or agree with the content, comments, opinions or statements made in the SAMENA TRENDS by any entity or entities or persons. Information, products, or services promoted in the TRENDS by other than the SAMENA Council belong to their respective entity or entities and are not representative of the SAMENA Council. The SAMENA Council hereby expressly disclaims any and all warranties, expressed and implied, including but not limited to any warranties of accuracy, reliability, merchantability or fitness for a particular purpose by any entity or entities offering information, products and services in this eMagazine. The user agrees that The SAMENA Council is not responsible, and shall have no liability to such user, with respect to any information, product or service offered by any entity or entities mentioned or advertised in this publication. The SAMENA Council's only liability, in the event of errors, shall be the correction or removal of the erroneous information after verification.

CONTENTS

04 EDITORIAL

17 REGIONAL & MEMBERS UPDATES

- Members News
- Regional News

63 CONNECTIVITY UPDATES

- Satellite News

68 WHOLESALE UPDATES

- Wholesale News

74 TECHNOLOGY UPDATES

- Technology News

82 REGULATORY & POLICY UPDATES

- Regulatory News
- A Snapshot of Regulatory Activities in the SAMENA Region
- Regulatory Activities Beyond the SAMENA Region

ARTICLES

52 Avaya's Environmental, Social, And Governance Strategy — Creating Better Experiences Worldwide

59 5G Roaming: Key Elements for a Successful Launch

65 Saudi Arabia: Success Factors and Advancements Towards Becoming the Leading Regional Technology Hub

80 Digitalization and Sustainability to Revolutionize Telecom Energy Management

FEATURED

13



stc Strives Forward in Driving Digital Transformation in the Region

SAMENA COUNCIL ACTIVITY

05

At the 1st Annual Meeting of the ITU's Partner2Connect Digital Coalition, SAMENA Telecommunications Council Presses Upon Intensified Global Collaboration...

06

SAMENA Council Advocates Enablement of Sustainable ICT Environment to Overcome Sustainability and Climate-Action Challenges

09



SAMENA Council, in Strategic Collaboration with the ITU, Saudi CST Commission, and Leading Telecom Operators, to Hold the Industry's First "RISE" Conference on January 11th 2023 in Riyadh

CONTENTS



**Let's advance together digital transformation for all!
Let's Partner2Connect!**

Sustainable ICT Development & Digital Enablement

Presently, economic growth and sustainability across every function of business and life are among the most pressing focus areas for the ICT Industry. It is important to recognize how digital solutions and ICT infrastructure can help our region in achieving digital-economy goals as well as in realizing green, low-carbon and high-productivity based economic transformation. Needless it is to say, such transformation should be human-centric, digitally-powered, and be mindful of the needs of the next generations and the environment.

Telecom/ICT Private Sector, on its evolutionary as well as revolutionary path, is creating new opportunities, digitally enabling business and societal functions, and creating new experiences. It is also strengthening the digital foundation on which educational delivery, financing services and inclusion, efficient municipal processes, for example, will be carried out in a world of smart connectedness.

At this stage, both as society and as industry, sustainable ICT development requires access to new capital and new funding and financing mechanisms to build new or revamp existing digital infrastructure. This is required across all countries and such capital investments have to come from a broad range of contributors. Incentives would play a critical role in this regard. The role of leading financing institutions, such as those with which SAMENA Council is closely engaged within the SA-ME-NA region in building collaboration bridges with leading ICT industry players, can also be a game-changer in future ICT development and digital enablement.

For all collaborations and intra and inter-

industry initiatives to yield good outcomes for socio-economic transformation and service delivery, adequate underlying ICT infrastructure is crucial, well-supported by Telecom Operators and financially sustainable to absorb and maintain all future energy efficiency and sustainability needs.

Creating a sustainable ICT environment as the enabler of a sustainable digital economy is both a challenge and opportunity area, especially as greater resource mobilization for building future digital infrastructure emerges as a priority need. As the year 2023 approaches us and brings new challenges, opportunities, and imperatives to work ever more closely together, SAMENA Council anticipates eventful months ahead, starting with its RISE Conference, which would steer the discussion on ICT sustainability and digital infrastructure development from multiple angles to SAMENA Council's collaboration with both regional and global bodies on elements that would be necessary for ensuring ICT sustainability. Fruitful engagement and outcomes expected from deliberations with the Industry stakeholders and decision-makers from across industries would also be an enabler of the Council's endeavors throughout the new year.

At the conclusion of 2022 and the dawn of 2023, I wish all colleagues, friends, leaders, and resource mobilizers of the Industry a Happy New Year and extend the Council's best wishes to stc Group, Mobily, China Mobile, the ITU, the Saudi CST Commission, DCO, and SAP Signavio, and valued Members of SAMENA Council on their valued collaboration in our upcoming RISE Conference in Riyadh. May the year 2023 bring prosperity and new successes in digital transformation and enablement to all. 🌱



Bocar A. BA
Chief Executive Officer
& Board Member
SAMENA Telecommunications
Council

SAMENA COUNCIL ACTIVITY

At the 1st Annual Meeting of the ITU's Partner2Connect Digital Coalition, SAMENA Telecommunications Council Presses Upon Intensified Global Collaboration to Fund & Finance Digital Broadband Infrastructure and Green ICTs

SAMENA Telecommunications Council's CEO Bocar BA, during the Partner2Connect Digital Coalition's first annual meeting in Geneva, emphasized the importance of strong global partnerships and cooperation to accelerate progress-making toward fulfilling the Sustainable Development Goals. BA reiterated that

To advance further the goal of sustainable digital transformation, BA highlighted the need for access to new capital and stressed that funding and financing mechanisms, approaches and infrastructures must be made available and efficiently put in place across all countries and in LDCs to support the scaling of sustainable ICT solutions. To ensure that investments are sustainable and come from a broad range of contributors, incentives must be made central to policies going forward.

Bocar BA, CEO & Board Member of SAMENA Council

the key areas of collaboration in being able to move forward with regards to scaling sustainable digital transformation include appropriate financing and funding mechanisms, including incentives for the private sector to invest, and infrastructures needed for scaling. He also underscored collaborative pathways for a green ICT sector, including for space, as key to achieving a sustainable future. Bocar BA commended the achievements of the P2C initiative to bring together stakeholders from the entire spectrum of the digital ecosystem, and beyond. He highlighted the tremendous efforts that the private sector has committed to connecting the unconnected. To advance further the goal of sustainable digital transformation, BA highlighted the need for access to new capital and stressed that funding and financing mechanisms, approaches and infrastructures must be made available and efficiently put in place across all countries and in LDCs to support the scaling of sustainable ICT solutions. To ensure that

investments are sustainable and come from a broad range of contributors, incentives must be made central to policies going forward. BA also highlighted in this regard that key recommendations are available in the BCom's 21st Century financing, funding, and investment models WG Report, which has particularly described and recommended how different economic stakeholders can be enabled to contribute to digital infrastructure and how demand-side initiatives can be taken to foster adoption. The first Annual Meeting of the P2C Coalition took place on 8 December 2022 to report on progress on the implementation of pledges made through the Coalition, celebrate the announcement of new pledges and commitments, discuss the challenges and opportunities for connecting the unconnected at specific breakout sessions, as well as network and share experiences to further advance global digital transformation. The meeting was attended by over 600 participants. 📺



SAMENA Council Advocates Enablement of Sustainable ICT Environment to Overcome Sustainability and Climate-Action Challenges

SAMENA Council, speaking at the 11th International Envirocities Conference in Fujairah - UAE, and represented by CEO and Board Member, Bocar BA, advocated the need for realizing green, low-carbon and high-productivity based economic transformation, while remaining human-centric and sustainable in the long-run. Describing the requirements for realizing the desired ICT environment, full of digital possibilities, digital solutions and applications, and bearing positive impact on both business and citizens, SAMENA Council corroborated the imperatives and initiatives being led by Telecom Operators in prioritizing sustainability and climate action across business operations. Bocar BA, citing the UAE as one of the key markets where sustainable ICT infrastructure development, inclusion-based digital transformation, and green energy consumption are materializing from vision to reality, stated: "Many countries, especially the UAE, have stepped-up efforts to transform economies towards sustainable green economies with the help of ICTs and the introduction of future visions that have sustainable transition at their heart. The UAE is an excellent example of this, where happiness levels and productivity are now higher than before, enabled by strong ICT infrastructure." To



overcome sustainability challenges in the Arab region, BA mentioned a bi-dimensional approach, whereby, firstly, ICTs should undergo transformation and be developed to be more environmentally sound and less carbon-intensive – a necessity that various Telecom Operator members of the SAMENA Council are addressing, for example, via climate-action collaboration memoranda; and, secondly, ICT-enabled

solutions should be deployed to help steer the region towards a more sustainable and energy efficient future. SAMENA Council also emphasized that for all of the initiatives to work, however, adequate underlying ICT infrastructure is crucial, well-supported by Telecom Operators and financially sustainable to absorb and maintain all future energy efficiency and sustainability needs. Creating a sustainable ICT environment as the enabler of a sustainable digital economy is both a challenge and opportunity area, especially as greater resource mobilization for building future digital infrastructure emerges as a priority need. SAMENA Council's intervention at the 11th Envirocities Conference followed a similar message delivered earlier during the Arab sustainability week, whereby the Council had advocated on behalf of Telecom Operators the need to adopt and sustain implementable policy-making and enabling regulatory approaches, to help set the right incentives in place and to move forward with the region's green initiatives. 🌱

"Many countries, especially the UAE, have stepped-up efforts to transform economies towards sustainable green economies with the help of ICTs and the introduction of future visions that have sustainable transition at their heart. The UAE is an excellent example of this, where happiness levels and productivity are now higher than before, enabled by strong ICT infrastructure."

Bocar BA, CEO & Board Member of SAMENA Council

Cybersecurity Compliance Merits Incentives for Telecom Operators and Preservation of Commercial Sensitivities, Says SAMENA Council

SAMENA Council, during the recently held Global Cybersecurity Forum in Riyadh, organized by the Saudi National Cybersecurity Authority (NCA), voiced the views of its Members and reiterated the need to commit to ensuring digital inclusion while balancing key aspects of digitalization, including countering existing and emerging cyber vulnerabilities. Bocar BA, CEO and Board Member of the Council, in his Intervention “cybersecurity at the heart of the next-gen telcos”, building on the views of SAMENA Council’s community of telecom service providers and network technology providers, described how the challenge of connecting 2.7 billion still-unconnected people around the world and the connectedness of billions of devices and machines that are emerging as a part of IoT and industrial IoT, require adaptation of the private-sector players within the digital ecosystem and balancing digitalization with security of the cyberspace. Bocar BA emphasized

that “Given the role of Telecom Operators at the nucleus of the digital ecosystem, Operators must unify and harmonize their security requirements and conformance obligations to prevent fragmentation. Isolated initiatives introduce complexity but do not demonstrably improve security. At the same time, regulatory and business expectations and priorities for Operators and Regulators should be aligned. Cybersecurity measures and costs incurred in compliance to regulatory requirements by the Private Sector be rewarded with incentives.” A longstanding desire of Telecom Operators to evolve from being telecom companies to being technology companies is coming to life in this age of 5G. As a host of digital experiences are increasingly made possible, the foundation for the next “G” is being created. On the road to universal connectivity and new economic activity, Operators and policymakers must align themselves, and framework of security processes, such as

“Given the role of Telecom Operators at the nucleus of the digital ecosystem, Operators must unify and harmonize their security requirements and conformance obligations to prevent fragmentation. Isolated initiatives introduce complexity but do not demonstrably improve security. At the same time, regulatory and business expectations and priorities for Operators and Regulators should be aligned. Cybersecurity measures and costs incurred in compliance to regulatory requirements by the Private Sector be rewarded with incentives.”

Bocar BA, CEO & Board Member of SAMENA Council



Network Equipment Security Assurance Scheme (NESAS) and Security Assurance Specifications (SCAS) should become the Mobile networks regulations standards. The complexity of the ecosystem, access to the network, and numerous uses of the communication infrastructure, inherently make network and data security daunting challenges. Moreover, Operators, given cloudification rates across various sectors, also need to focus on telco Cloud-native developments and securing the Edge, to help better strategize on network security, privacy, and data security offerings. Mobile

As a host of digital experiences are increasingly made possible, the foundation for the next “G” is being created. On the road to universal connectivity and new economic activity, Operators and policymakers must align themselves, and framework of security processes, such as Network Equipment Security Assurance Scheme (NESAS) and Security Assurance Specifications (SCAS) should become the Mobile networks regulations standards.

Bocar BA, CEO & Board Member of SAMENA Council

networks are critical infrastructure and need to be robust and reliable. While they must ensure trust-building among the end-users to sustain the Internet, Operators may themselves need to adopt “Zero Trust” architecture principles within to ensure security and safety of the cyberspace. While preserving their commercial advantages and internal efficiencies, Operators must necessarily collaborate to synchronize their needs and requirements, and strategic messaging on the cybersecurity front. 📍

SAMENA Council Highlights Elemental Role of Microwave in Transitioning to 5.5G Development in the Region and Requirements for Achieving New Connectivity Milestones

SAMENA Council, represented by its CEO – Bocar BA, has drawn attention to connect the 2.7 billion people still without any access to broadband connectivity, whether fixed or mobile. The Council notes that while the status quo is changing gradually—and in some rare cases, quickly—billions of dollars are still required to complement the trillions that have already been invested so far in connecting the 5.3 billion people. SAMENA Council believes that future connectedness, including transition from 5G to 5.5G and beyond, requires accelerated implementation of new technologies and new forms of multi-stakeholder cooperation in digital development, centered on meeting “access, affordability, and equality” KPIs. Lately, SAMENA Council has been actively advocating on the need to fund and finance digital infrastructure through innovative financial approaches. Advocating at the Global Microwave Industry Forum, Bocar BA, emphasized that “Two things are categorically clear - First, we need to attract vast investment in order to support sustainable broadband development and digital connectedness —ranging from people to people, people to machines, to machines to machines. Second, especially for Telecom Operators, we need strategic adaptation to physical realities of telecom network design, accessibility, investment viability, and what is around us in terms of network innovations and time-tested and new microwave transport technologies.” BA, in his message, was acknowledging and referring to the GCC region’s leadership and to the Telecom Operators’ and Regulators’ powerful role on the 5G front, not only in terms of early adoption but also in terms of data transmission speeds. The region’s 5G momentum has been boosted by a number of factors, including the economic recovery from the pandemic, rising 5G handset sales, network coverage expansions and overall marketing efforts. Referring to the ultimate goal of making 5G a success for the Private Sector, Policymakers and Regulators alike, and as 5.5G emerges with its new use-cases, BA reiterated that fifth-generation network expansion must extend from urban areas to far beyond into far-flung territories. Under this scenario, multiple

BA, in his message, was acknowledging and referring to the GCC region’s leadership and to the Telecom Operators’ and Regulators’ powerful role on the 5G front, not only in terms of early adoption but also in terms of data transmission speeds.

variables, including cost, time, complexity, right-of-way, and other administrative, regulatory, and business pressures, have to be balanced out, which could affect deployment and inhibit growth ambitions. Because microwave has played a major role in mobile technology rollouts in the region, and because microwave transport capacity has now evolved from hundreds of megabit-per-second capacity to tens of gigabit-per-second capacity and offers low-cost, quick installation and reliable, secure operations, 5G/5.5G capable microwave, supported by a sound wireless backhaul strategy, holds the strongest potential for accelerating 5G deployments and developing 5.5G through consensus-driven approaches. In order to address impediments to adoption and to bring its benefits to the region, as a trusted industry voice and through its private-sector representative role within the ITU’s Industry Advisory Group for Development Issues (IAGDI), SAMENA Council will play its role in fostering 5.5G development, which includes agreeing on definitions and standardization way forward. SAMENA Council recognizes that fifth-general digital infrastructure development in the region has also been carried out successfully due to advancements in Fiber, Cloud, latest Radio Access, and Microwave Backhaul, as well as several other factors, including Operators’ willingness to tread through challenging paths. 📍

SAMENA Council, in Strategic Collaboration with the ITU, Saudi CST Commission, and Leading Telecom Operators, to Hold the Industry's First "RISE" Conference on January 11th 2023 in Riyadh



The banner features the SAMENA logo (Telecommunications Council Building Digital Economies) and the RISE IN RIYADH logo. It lists sponsors: ITU, CST, stc, Mobily, China Mobile International, SAP Signavio, and Digital Cooperation Organization. The main text reads: "Sustainable ICT Development The Future of Digital Visions & Cross-Industry Innovation" followed by the date "11th January, 2023" and location "Fairmont Riyadh Riyadh, Saudi Arabia". The background is a futuristic cityscape with a network overlay and a glowing planet.

SAMENA Telecommunications Council announces that its first Rising for Industry Sustainability & Efficiencies (RISE) Conference will be held on 11th January 2023 at Fairmont Riyadh, Saudi Arabia, in strategic collaboration with stc Group, Mobily, China Mobile International, the Communication, Space & Technology Commission (CSTC) of Saudi Arabia, and the 193 Member States and private-sector driven UN premier ICT agency, the International Telecommunication Union (ITU).

Recent policy and regulatory developments in Saudi Arabia and the GCC region, particularly with respect to accelerated focus on digital transformation; adopting

technology and regulatory sandboxes; making beneficial use of 5G investments; network evolution toward 5.5G/5G-Advance; rising discussion on 6 GHz; new cybersecurity imperatives; emergence of metaverse; the role of financial services industry and other sectors; and the overarching critical requirement of ICT ecosystem sustainability, are serving as catalysts to rethink investment, sustainable operations, end-user and enterprise service delivery, while delivering on globally-agreed digital development expectations. Rising synergies among ICT Industry and other Industries, especially the Financial Services industry, also merit repositioning of perspectives.

Eng. Olayan M. Alwetaid, Group CEO of stc and Chairman of the Board of Directors of SAMENA Council, has stated: "As the Kingdom's maturity shifts into a world-class digital nation driven by Vision 2030, among the many initiatives now taking place within the Kingdom, the RISE Conference is structured to address the emerging needs and challenges of the digitally transforming businesses, economic sectors, telecom industries and the society at large becoming a platform toward sustainability in investment and improved collaborations."

Mr. Bocar BA, CEO & Board Member of SAMENA Council views that "The RISE Conference as a new dimension of SAMENA

Council's extended support to the region's ICT and digital transformation visions via greater and more advanced collaboration with Telecom Operators and Tech Providers. RISE is also a demonstration of the Council's commitment to remaining in constant engagement with regional operators, regulators, regional government bodies, and global institutions."

At a time when MCIT, under the leadership of H.E. Eng. Abdullah Alswaha, Minister of Communications and Information Technology, is leading key digitalization efforts across the public sector and when a robust and cutting-edge digital architecture has been created in Saudi Arabia in alignment with the national Vision 2030, the RISE Conference can help extend knowledge support on multiple areas. Similarly, the Saudi Communication, Space & Technology Commission (CSTC, formerly CITC) also has been a decisive force that has empowered the Saudi ICT ecosystem to progress and grow in the desired national policy direction.

In this light, **H.E. Governor of CSTC, Dr. Mohammed Altamimi** has emphasized that "Regional regulatory authorities need to enhance strategic cooperation in developing the digital economy and in harnessing digital technologies for sustainable economic development. Sustainability and efficiency centric

initiatives such as the SAMENA Council RISE Conference can help take our dialogue forward (quote from HE Governor suggested). The Commission is pursuing a long-term vision of digital transformation and sustainability at its heart. SAMENA Council's RISE conference should help star the year 2023 with fresh perspectives on ICT sustainability and how ecosystem players plan to strive forward in such goals, which the Commission fully supports."

The ITU, as UN specialized ICT agency, has been strongly promoting the need to address challenges and opportunities offered by ICTs in the areas of innovation, governance, education, job creation and economic growth. This demands newness in the way key industry decision-makers conduct dialogue on pertinent issues.

H.E. Ms. Doreen Bogdan-Martin, the first woman Secretary-General-elect and the current Director of Telecommunication Development Bureau of the ITU, reiterating the need for collaborations and partnerships, has stated that: "RISE is taking place at a key moment. As the world rapidly adopts digital technologies, greater cross-sector collaboration is urgently needed to help every country advance on its digital transformation journey. Best-practice regulation and policy making play a crucial and catalytic role in advancing digital inclusion, empowering

governments, industry and consumers to capitalize on the many exciting opportunities new technologies can bring."

RISE is a new flagship leaders-centric project by SAMENA Council to assist proactive engagement and industry discourse with Saudi Administration as well as regional policymakers and regulatory authorities. The Conference is structured on the essential requirement of addressing emerging needs and challenges of the digitally transforming businesses, economic sectors and industries, and the society at large. RISE, as ICT sustainability-driven industry meeting, also has the objective of becoming the platform for recognizing, appreciating, and guiding fifth-generation collaborative regulation and policy requirements and achievements, to help incentivize the Operator Community, Sectors and Verticals, and the Private Sector, at large, toward sustainability in investment and improved collaboration.

RISE is inviting the participation of all ICT and non-ICT industry stakeholders. Participation can be requested by writing to SAMENA Council (smnrise@samencouncil.org) or by visiting RISE 2023 in Riyadh - Sustainable ICT Development (samencouncil.org) 

Avaya Joins SAMENA Council to Support Industry Advocacy and Explore Partnerships in Creating Game-Changing Digital Experiences Across Industries



Experiences That Matter

SAMENA Telecommunications Council has announced that Avaya, a global leader in solutions to enhance and simplify communications and collaboration, has joined its membership of leading communications service providers and technology providers. Bocar BA, welcoming Avaya to the SAMENA Council membership, stated that “Avaya’s cloud communications and workspace collaborative expertise across the telecommunications, education, healthcare, media, financial services, and public sectors provide an ideal opportunity for Avaya and SAMENA Council to build knowledge, voice issues relevant to these sectors, explore new business opportunities for Avaya, and create new advocacy and partnership potential with the Council’s membership as well as

the South Asia – Middle East- North Africa region.” With over 90,000 customers in over 190 countries, Avaya is shaping what’s next for the future of work, with innovations and partnerships that reimagine the ways people and businesses engage with and experience the world. Avaya’s multi-cloud application ecosystem power personalized, intelligent, and effortless customer and employee experiences. And its packaged communications and collaboration applications and APIs can be combined to compose AI-enabled total experiences that each interaction and moment demands. “SAMENA Telecommunications Council is doing fantastic work in creating a sustainable ICT environment and broadening value creation in key vertical industries. We’re proud to be a part of this vibrant community, and look forward to contributing to the council’s efforts in helping to enable digital transformation across the South Asia-Middle East-North Africa region,” said Nour Al Atassi, Director - Service Providers, Avaya. With its established and industry-wide recognized aim of addressing telecoms ecosystem priorities, enabling access to greater region-wide collaboration in digitalization and digital transformation, SAMENA Council actively advocates on behalf of its members and engages closely with private-sector stakeholders, including regional operators and regulators, and policymakers. SAMENA Council is pursuing improved policymaking, agile regulation, and close collaboration among the digital ecosystem players, and is using its internal advocacy support mechanism as well as collaborated knowledge-creation highlights among government and private-sector stakeholders’ issues, such as those relating to spectrum, need for accelerated digitization and sustainability in digital development, investments, operations, and the environment. 🌱

“Avaya’s cloud communications and workspace collaborative expertise across the telecommunications, education, healthcare, media, financial services, and public sectors provide an ideal opportunity for Avaya and SAMENA Council to build knowledge, voice issues relevant to these sectors, explore new business opportunities for Avaya, and create new advocacy and partnership potential with the Council’s membership as well as the South Asia – Middle East- North Africa region.”

Bocar BA, CEO & Board Member of SAMENA Council

فول FULL
5G

GO
FULL 5G

The first and only network to take 5G further

#go_full_5G

stc



stc.com.kw

stc Group Strives Forward in Driving Digital Transformation in the Region



"We will continue working on accelerated pace, providing the latest technological solutions in addition to developing a reliable digital infrastructure within our digital ecosystem. This will boost the Kingdom's position as a leading digital service center through innovative projects and global partnerships. Thus, enabling the digital transformation of the public and private sectors will reflect in strengthening the digital economy in harmony with the Kingdom's Vision 2030."

Olayan M. Alwetaid
CEO
stc Group

stc

The Saudi Vision 2030 has catalyzed tremendous mobilization of resources and investments in the ICT sector and has affirmed the need for innovative digital services and capacity-building for the Saudi citizens.

stc Group, as the leading digital enabler in Saudi Arabia as well as the region, has been at the forefront of adopting and integrating advanced technologies to boost the Kingdom's socio-economic transformation by harnessing the power of digital communications technologies. Ultimately, it aims to help realize the country's considerable potential and achieve its Vision 2030 goals by accelerating the digital transformation of its burgeoning and thriving industries. To this effect, stc group, in addition to its digital services and solutions, has also specifically focused on modernizing the nation's industrial landscape, spurring the shift from traditional factories to automated facilities powered by robots and artificial intelligence.



**digitizing towards
a sustainable and
efficient future**

The growth and expansion plan launched by stc Group at the beginning of the second decade of the 21st century has since driven the digital transformation journey in the Kingdom and has undergone evolution as a result of the technical development witnessed in the region.

Over the past few years, stc Group has transformed from a mere communication and internet service provider to being a leading regional digital enabler. The comprehensive strategy launched by the group had a transformative role in catalyzing digital transformation in the GCC region's largest economy, further driving investment and sector diversification in Saudi Arabia.

During the past two years, stc Group has launched subsidiaries in the fields of cybersecurity, Internet of Things, cloud computing, infrastructure and 5G technologies that serve different gulf communities and support the digital transformation in the region. Furthermore, the group obtained the most valuable brand certificate in the Middle East region in the telecommunications sector, according to the classification of Brand Finance International. The success story of this development, growth and accomplishments achieved by the group extended to become the main driving force of the communications and information technology sector for both Kuwait and the Kingdom of Bahrain, in addition to its home market of Saudi Arabia.

stc Group has launched subsidiaries in the fields of cybersecurity, Internet of Things, cloud computing, infrastructure and 5G technologies that serve different gulf communities and support the digital transformation in the region.

stc Group's Accelerated Investment & Growth Path in the GCC Region

The beginning of the group's success story in the expansion and growth process accelerated in Kuwait, where, in its first year, it attracted half a million customers and within only four years it began to achieve profitable returns for investors. The company's official listing on the Kuwait Stock Exchange was one of the highlights of success and growth, as the volume of retained profits increased with the development of the company's profits. It also acquired the second place in terms of revenues and market share from the subscribers, afterwards the achievements continued until it acquired a market share of about 36% of the sector's revenues in 2021.

In the Kingdom of Bahrain, stc Group entered the telecom market in 2010 as the third telecom operator in the Kingdom. The group quickly became a major driving force towards achieving the digital transformation vision, as it captured 41% of the market revenues, and proved its strength in the competition to become the first operator in the mobile phone markets, carrier sector customers and operators in the Kingdom of Bahrain, as well as the fastest performing company throughout the region and the first in developing local, regional and global networks, through continuous investments in infrastructure development. It was approved as the first commercial operator of the 5G network in Bahrain in the field of cybersecurity, and cloud computing. The company also provided services outside the scope of communications, including financial services and insurance services at the highest levels, in order to keep up with the requirements of customers' daily lives.

stc's Contributions to Fulfilment of ICT Visions in Kuwait and Bahrain

The year 2019, witnessed the launch of the unified brand in Kuwait, Saudi Arabia and Bahrain. stc group also launched an updated corporate identify and developed a strategy befitting the company's basic objectives during the subsequent years in 2019 to enhance the process of enabling the company's digital transformation in line with the national visions in each country.

In Kuwait, the Kuwait Strategic Vision 2035 seeks digital transformation among the many goals set by the state, to keep pace with the internet services at all levels. stc group has had a fundamental role in accelerating the transformation process, as the company's acquisition of Quality-net and its transformation into "solutions by stc" had a prominent role to be the active technical arm in enabling the business sector and supporting local projects. It announced the establishment of the 5G Innovation Center in 2019, with the aim of exploring, developing and launching the uses of advanced 5G technologies. Moreover, it provided a range of digital solutions for companies that include data centers, infrastructure support and applications for companies. In addition, stc group introduced an IoT strategy that allowed companies to manage their resources more efficiently and make the most of their business models.

Based on the company's strategy and the promising projections of the institutional sector in Kuwait, the company undertook a major transformation process to meet the needs of customers and enrich their experiences in the information and communication technology field, which was highlighted in the company's "AHEAD" strategy. The company was keen to improve its efficiency and internal capabilities in this sector through its acquisition on the entire capital of the Electronic Gate Holding Company in April 2022, to keep pace with the latest rapid global developments in the field of communications and information technology, and to provide the best integrated technical solutions to its individual and institutional clients. stc group successfully completed its capital increase during 2022 to reach KD 99.9 million by distributing 100% bonus shares to its shareholders. During the third quarter of 2022, stc's market share reached 39.8% of the telecom sector's revenues in Kuwait, for the first time since the company's establishment, to be at the forefront of the telecom sector in terms of revenue.

In Bahrain, stc Group contributed to supporting Bahrain's Economic Vision 2030. For the enterprise sector, the company developed a comprehensive

range of information and communication technology products, including cybersecurity, asset tracking, data hosting, and cloud services to serve this sector. To support service providers, the stc group has succeeded in consolidating its position as an empowered enabler, providing services to more than 400 national and international companies. The company also enhanced the customer service experience across all points of contact, as it always aimed to continue advancing the digital transformation in the Kingdom of Bahrain to become a digitally enabled societ.In Bahrain alone, stc group has invested

To support service providers, the stc group has succeeded in consolidating its position as an empowered enabler, providing services to more than 400 national and international companies.

more than \$2 billion in developing digital infrastructure. The company has remained at the forefront of launching innovative services in Bahrain, even becoming the first operator to launch 5G technology across the Kingdom. stc Bahrain has also worked to develop its innovation center and its platform for developing modern technologies for various sectors, and has also launched many digital services, including self-service machines (SSM), smart queue management service, and many other services, which contributed to providing an improved experience for customers by providing them with the opportunity to complete their transactions in a few seconds and in any time and place. The company launched a cyber security training academy, with the aim of raising awareness about potential cyber threats through its leading solutions in this field.

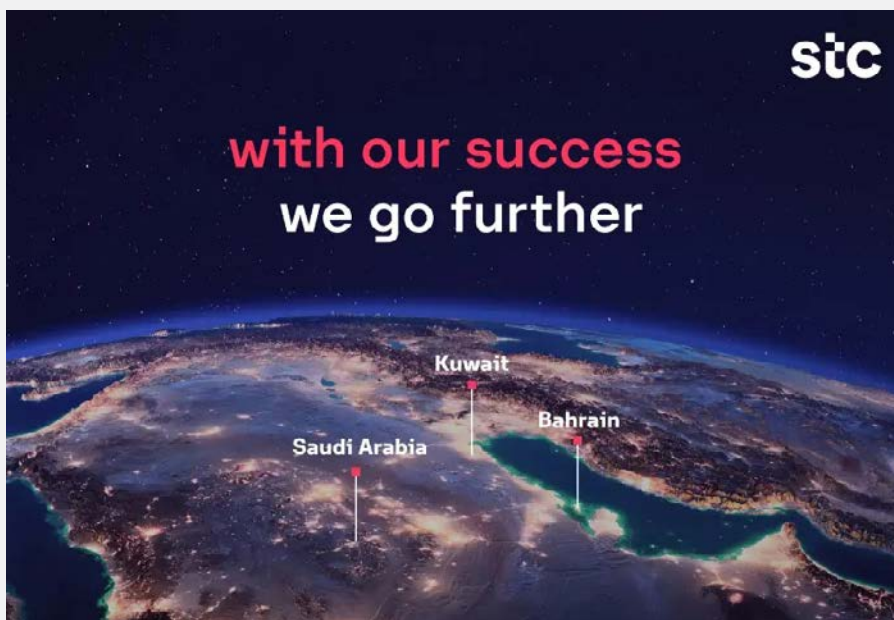

Investment in Sustainability and Social Empowerment

Since its establishment in Kuwait, stc group has been able to achieve many contributions and achievements to support the local community and its social responsibility agenda. It succeeded in participating across various initiatives in cooperation with various government agencies and private sector institutions to small and medium-sized companies that aimed at supporting and empowering the Kuwaiti society to achieve sustainability in line with Kuwait Vision 2035. The company focused its efforts in key areas such as health, sports, education, entrepreneurship, and the environment. It launched several initiatives, such as the "Safe Education" campaign in cooperation with the Ministries of Education, Health,



As the Group perseveres on its path to digital enablement throughout the GCC region, and with its various investments within the SAMENA region, stc group brand carries on with its legacy of digital and socio-economic empowerment, and to progress forward on both national ICT visions as well as the global Connect 2030 Agenda.

Interior, and Information, and the "Weyak" initiative to support local SMEs in enabling their digital transformation strategies.

stc Group is striving to consistently and continuously invest in the development of its human resources, as they form the cornerstone of its outstanding performance. It is endlessly focused on providing education and development programs, as it has effectively launched its e-learning programs through many recognized international organizations, such as LinkedIn Learning and Gartner, to continue providing training and development opportunities for employees. The company also launched its training academy "Academy by stc",

which seeks to empower employees with high potentials.

Leveraging its resources, expansive network, ecosystem and advanced infrastructure, stc group has pioneered novel ICT solutions and digital services that have stimulated the growth and development of various economic sectors Saudi Arabia, Bahrain, and Kuwait. As the group perseveres on its path to digital enablement throughout the GCC region, and with its various investments within the SAMENA region, stc group brand carries on with its legacy of digital and socio-economic empowerment, and to progress forward on both national ICT visions as well as the global Connect 2030 Agenda. 🌱

MEMBERS NEWS



stc and SkyFive Sign MoU to Introduce Broadband Inflight Connectivity to MENA

stc Group, the leading digital enabler in the region, and SkyFive Arabia, the leading provider of Air-to-Ground (A2G) based solutions and services, announced the signing of a Memorandum of Understanding (MoU) to introduce inflight connectivity (IFC) through A2G-based solutions to airlines in Saudi Arabia. With plans to further expand across the entire MENA region in the near future, the partnership will deliver unparalleled connectivity that will enrich passengers' travel experience. Through the MoU, stc aims to contribute towards the Kingdom's digital transformation while providing unrivaled connectivity, be it on the ground or in-air. Inflight connectivity through A2G-based solutions will enhance airline passengers' experience, who will benefit from access to high-speed connectivity, allowing them to experience high-quality (up to 4K) video-streaming, web browsing, and social media usage. Eng. Mohannad Makki, VP of Carrier and Wholesale at stc,

said: "Having seen Saudis' internet usage rocket by more than 92% in 2021 versus 2020, we know that our customers want to stay connected no matter where they are. Our partnership with SkyFive Arabia is the latest in a series of investments geared towards meeting the rapidly growing demand for high-speed and superior-quality connection services, by introducing innovative technologies that elevate the user experience. As the Kingdom's digital transformation accelerates, stc is paving the way for our customers and business partners to connect in more ways than ever." Eng. Hazem Bahy, VP of Sales and Head of Business Saudi Arabia at SkyFive Arabia, said: "We are pleased to partner with stc for this milestone that will benefit the Kingdom's aviation industry and beyond. Air-to-Ground brings broadband connectivity to the skies, providing airline passengers with an unmatched data experience. This unique service differentiator and digital enabler will undoubtedly enhance passengers'

experience so that they can enjoy the same great services in-air as on-ground." stc and SkyFive Arabia have already tested this state-of-the-art technology on a flight between Riyadh and Jeddah, in collaboration with the Communications, Space and Technology Commission (CST) and a leading airline company. Following this, the service is expected to be launched across all deployed routes in the Kingdom and the region by 2025. The MoU follows the CST's earlier announcement of stc as the auction winner for a 15-year license for both spectrum blocks - A2G-based network and mobile satellite services (MSS). The win supports stc's ongoing contribution towards the Kingdom's digital transformation, in alignment with the CST's mission to enable innovative NTN (Non-Terrestrial Network) technologies, provide end users with the latest generation of satellite technology, and to cover rural and remote areas in the Kingdom and beyond with the best telecom services.



The Minister of Human Resources and Social Development Crowns stc Group with 4 Awards

stc Group and its subsidiaries, channels by stc and solutions by stc attained 4 awards within the nationalization and work environment categories, during the 2nd edition of the labor awards, after competing with 10,000 private organizations. His Excellency the Minister of Human Resources and Social Development, Eng. Ahmed bin Sulaiman Al-Rajhi, handed over the prizes to the award winners. Eng. Abdullah Bin Abdulrahman Al-Kanhal,

Group Chief Strategy Officer received the award representing stc Group, while Eng. Faisal Al-Ateeq, CEO of channels by stc received the award and Eng. Moataz Al-Darrab, Chief Strategy Officer of solutions by stc received the award. stc Group, the digital enabler in the region won the working environment award for people with disabilities within the large and vast enterprises division, furthermore stc won the Saudization award for nationalizing

the communications and information technology sector. Also, channels by stc won the nationalization award in the wholesale and retail trade sector, while solutions by stc won the distinguished working environment award, within the large and oversize enterprises' division. stc Group achieved these awards due to its outstanding nationalization efforts. The group could attain higher percentages that reached to 92% with its localization program, in addition to many initiatives the group worked on, aiming to improve and develop the work environment, to become more flexible and attractive for local talents. Moreover, stc constantly extends concerns to balance work and life elements for all its employees. Besides, stc, regularly pursues its employees' needs across all level and categories, under all circumstances. This reflects the success of stc's strategy as a pioneering digital and national group that contributes to achieving the Vision's 2030 goals. It is worth mentioning that the labor award is an initiative along the many initiatives that the Ministry of Human Resources and Social Development has done to appreciate the efforts of distinguished establishments and private sector organizations in raising nationalization rates, complying to the standards of an innovative and attractive working environment, and investing in the development of their human resources, in line with the Kingdom's vision 2030.



The 9th Annual Internal Audit Conference Honors stc Group

His Excellency the President of the General Court of Audit and Chairman of the Board of Directors of the Saudi Association of Internal Auditors Dr Hussam Al-Anqari, honored stc Group for its digital support and sponsorship of the 9th annual internal audit conference, which was hosted in Riyadh, and it reflected the motto of "Elevating Impact". While Eng. Olayan Alwetaid, stc Group CEO received the recognition, the honoring was the result of stc's capability of being the leading digital enabler in the Kingdom, and as the digital sponsor of

the 9th version of the conference. The conference discussed the most important challenges of the internal audit profession and presented the best professional solutions and practices for the business environment. Eng. Alwetaid confirmed stc's commitment and interest to sponsoring the conference in contribution to enabling digital transformation and helping internal audit processes achieve the set objectives through adopting a regular approach which enables evaluating and improving the effectiveness of risk management and

internal controls. Eng. Abdullah AlEnezi, Internal Audit CEO at stc group participated in a session titled: "Preparing the internal audit to keep pace with the transformation plans". Within his session, he discussed the most important, current challenges of the rapid changes and transformations of the economy, the development of technology and the constant updates in regulations and legislation. Furthermore, he discussed ways to support the control system, allowing the business sector, to make an impact by adding value to push

development plans, leading to the success of the business sector, in accordance with best professional practices. The internal audit annual conference is a large gathering for Saudi and non-Saudi professionals interested in the field of internal auditing in KSA. A group of local and international leaders and experts meet during the conference to discuss the most important challenges facing the internal auditing profession, and the best professional solutions and practices in the field of internal auditing. The conference also highlighted the rapid changes that the world is experiencing today, the new governance challenges, risks, and compliances, as well as the role of regulators in supporting internal auditors and preparing them for further development plans.



stc Secures All Spectrum in CST's 2100MHz NTN Auction

Saudi Arabia's Communications, Space and Technology Commission (CST) has announced that it has completed its 2100MHz spectrum auction for non-terrestrial networks (NTN) technologies,

after a total of 32 bidding rounds. The two available spectrum blocks (1980MHz-2010MHz/2170MHz-2200MHz) were secured by Saudi Telecom Company (stc); the company will be required to build an Air

to Ground (A2G) network covering the air routes in the Kingdom with internet services, as well as to provide mobile satellite services (MSS) across the Kingdom.

CST Announces that STC has won both channels in the Spectrum Auction for NTN in the 2100 MHz Band

Auction Winner

Saudi Telecommunication Company

stc

License Duration **15** Years



ARABSAT Sponsor the 22nd Arab Broadcasting Festival

The Arab Satellite Communications Organization, Arabsat, announces its sponsorship of the 22nd edition of the Arab Broadcasting Festival, which will be held for the first time in Riyadh, from 9 to 12 November 2022, in partnership with the Arab States Broadcasting Union. The Saudi Broadcasting Authority organized this festival in the presence of more than 1,000 media professionals and an audience of more than 5,000 people. This annual festival aims to achieve several goals, including contributing to the development of Arab radio and television production and improving its quality to meet the aspirations of member companies and reflect the principles that underpin their work. Expressing he is delighted in participating in 22nd edition of the Arab Broadcasting Festival, Mr. Al-Hamed Al-Anezi, CEO of Arabsat declared: "We are very proud with our long-term strategic partnership with the ASBU, we have seen the fruit of this strong relation grow through turnkey projects as the global Arabic bouquet as well as our partnership agreement" MENOS" for exchanging



multimedia content over satellites. We believe that we are going on the right track that will allow us to deploy new technologies that suit the requirements of our customers in the Middle East." "This annual gathering has become a ritual for us in Arabsat. An essential meeting that give us intimate close up to hear our partners and customers' feedback to keep providing them with the best solution and services in the media and entertainment sector."

Added Alanezi The event will witness the participation of representatives of ASBU member corporations, working in the fields of staging, production and preparation of programs, as well as representatives of private Arab production companies, news agencies, and radio and TV stations. Representatives of private radio and television networks, international radio and television unions will also attend the festival.



Etisalat by e& Partners with Abu Dhabi Global Market to Digitally Enable Startups and Businesses

Etisalat UAE, branded etisalat by e&, has partnered with Abu Dhabi Global Market (ADGM), the capital's financial center, to provide digital solutions and products to all new tenants and startups, accelerating its digital transformation journey and vision to deliver the best-in-class customer experience and become a world-class innovative financial hub. The ADGM has established itself as one of the world's leading international financial centers, putting Abu Dhabi firmly on the international business map. In just seven years, the financial hub has become home to more than 5000 entities, including international financial institutions, professional services firms, investors and start-ups. Through

this partnership, etisalat by e&'s digital solutions will address the digital needs of businesses by providing benefits that will facilitate office, remote and hybrid working. The next-generation Internet solutions are comprehensively designed to provide high-speed Internet access based on the size of the workforce, as well as specific user benefits The proposition is an all-in-one solution designed to ensure complete business mobility by equipping each employee to work remotely or in a hybrid work environment. Employees will have access to user packages that include a multitude of collaboration, communication, productivity and security tools. Esam Mahmoud, Senior Vice President,

SMB, etisalat by e&, said: " Businesses undergoing digital transformation are constantly looking at how they can add more value for all their customers. ADGM is looking to innovate and expand its offering to advance its competitive ecosystem and support the ease of doing business with and from the region. Through this partnership, etisalat by e& will bring together its network capabilities, teams and expertise to meet the needs of the financial center's growing startup and enterprise community." "This will enhance ADGM's digital platforms, intelligent services and applications, improving the overall experience of hosting a business. This collaboration and our efforts to bring

this digital connectivity is part of the overall vision of the UAE leadership to chart a course towards a diversified, knowledge-based economy and attract investments that generate long-term benefits for society and future generations." Hamad Sayah Al Mazrouei, Chief Operating Officer at ADGM said, "ADGM is delighted to partner with Etisalat by e& to bolster the digital transformation of the UAE economy. This partnership is in line with and is an extension of our commitment to foster, protect and strengthen Abu Dhabi, UAE and the wider region's financial landscape. We look forward to working with Etisalat by e& to digitally empower the ADGM community, *ease customer onboarding journey through integrations* and positively contribute towards the prosperity of the economy." etisalat by e& offers a variety of solutions to businesses at ADGM, including the e-Store, which helps businesses to have the ability to build their own digital platforms with the etisalat by e& e-Store solution, a fully integrated shop that allows SMBs to sell their products online, manage payments through etisalat by e&'s secure payment gateways and other platforms in the region for seamless payments. Businesses can

upload all their products and publish their website in minutes, integrate their shop configuration, categorize their products, secure their payments, configure and manage their shop on mobile. e-Store is designed to provide SMBs with a first-class website experience that meets their business needs. They can create a professional looking website without using a web designer, as it contains over 1,000 free ready-made templates covering more than 80 SMB verticals. Its drag-and-drop interface has a photo editor, video clips, free stock images and Google Maps, among other features. ADGM fosters a holistic and thriving ecosystem that will enable the growth and development of local and international enterprises from across the region and around the globe. The business infrastructure at ADGM is built around three independent authorities that work together to help companies and entities operate seamlessly, innovate and grow, namely the ADGM Courts, the Financial Services Regulatory Authority (FSRA) and the Registration Authority (RA). These three entities guide SMEs, start-ups and international entities throughout the entire business lifecycle, right from the launch or registration and all the

way to portfolio and geographic growth. Etisalat Group has changed its brand identity to e&, effective on February 2022. Its strategy aims to accelerate growth through the creation of a resilient business model represented by Group's main business pillars. The telecoms business currently continues to be led by etisalat by e& in the Group's home market and e& international markets, upholding the Group's rich telecoms heritage, bolstering the strong telecoms network and maximizing value for the Group's various customer segments. Ramping up the digital services for individuals to elevate their digital-driven lifestyle, e& life brings next-generation technologies through smart platforms in entertainment, retail and financial technology. e& enterprise focuses on maximizing value through its end-to-end solutions in cybersecurity, cloud, Internet of Things (IoT) and Artificial Intelligence (AI), as well as deploying mega projects, in order to enable the digital transformation of governments, large-scale enterprises and corporates. e& capital allows the Group to focus its efforts on driving new mergers and acquisitions while maximizing shareholder value and strengthening the Group's global presence.



e& Becomes the First UAE Private Sector Entity to Join the UAE Independent Climate Change Accelerators (UICCA)

In line with its ambitions to become a regional leader in climate action, e& (formerly known as Etisalat Group), the global technology and investment conglomerate signed a significant Memorandum of Understanding (MoU) with the UAE Independent Climate Change Accelerators (UICCA), at the UAE Pavilion, as part of its participation at COP27, the 27th Conference of the Parties of the UNFCCC, currently taking place in Egypt. The strategic partnership marks e&'s stance as the first entity from the UAE's private sector to join the UICCA. The move reaffirms the group's commitment towards the climate action efforts led by the Group while supporting the transition to a greener economy. Sheikha Shamma bint Sultan bin Khalifa Al Nahyan, Executive Director of UICCA, said: "As the driving force towards actualizing the UAE's commitment to net zero by 2050, UICCA's mission is to enable and energize an ecosystem of public and private entities that have shared values and a joint vision of building a sustainable future." Sheikha Shamma added: "Today's signing with e& at COP27, as the first private sector entity to join the UICCA, is a tremendous achievement that depicts our progress towards our climate action aspirations, and we look forward to partnering together

and pushing forward with our goals to preserve natural ecosystems for future generations." Sheikha Shamma concluded by stating: "This marks the beginning of the UICCA's concentrated efforts towards supporting the UAE's sustainable solutions commitment, as well as the acclaimed actions and efforts that have already been undertaken by the Egyptian presidency as part of our concerted efforts towards the 'Decade for Action'. "I sincerely look forward to working in close cohesion with all of our peers within the global sustainability community and achieving tangible outcomes here at COP27 and COP28 UAE." "Sustainability is at the heart of everything we do, and we believe that tangible sustainable goals are essential to ensure a better future for generations to come" said Hatem Dowidar, Group CEO, e&. "Today, we have taken an important step forward in visualizing our sustainability strategy and supporting the UAE's net zero climate action ambitions, and we remain confident that the signing of the MoU will become a catalyst for making the difference as we inspire and motivate other corporates and organizations to drive the necessary change." "The telecoms sector has always been a key enabler for other sectors to achieve their sustainability goals. Together with UICCA,

we will create an action group that will drive implementation of sustainability-based solutions in UAE's ICT industry." UICCA is a non-partisan climate action entity that functions as a think tank, providing evidence-based policy recommendations on climate action to both the public and private sector. Working across sectors industry groups UICCA will actively work to build industry coalitions to facilitate the region's transition to a green economy through activities that stimulate GDP growth, increase job creation, and reinforce UAE's position as a global hub for best practices in Environmental, Social and Governance (ESG). Etisalat Group had changed its brand identity to e&, effective from 23 February 2022. Its strategy aims to accelerate growth through the creation of a resilient business model representing the Group's main business pillars. The telecoms business currently continues to be led by etisalat by e& in the UAE which is its home market and by e& international in the global markets, upholding the Group's rich telecoms heritage, bolstering the strong telecoms network and maximizing value for the Group's various customer segments. Ramping up the digital services for individual customers to elevate their digital-first lifestyle, e& life brings next-generation technologies through smart



platforms in entertainment, retail and financial technology. To maximize the digital potential of governments, large-scale enterprises and corporates, e& enterprise focuses on delivering innovative

digital vertical value propositions through its end-to-end solutions in cybersecurity, cloud, Internet of Things (IoT) and Artificial Intelligence (AI), as well as deploying mega projects. e& capital allows the

Group to focus its efforts on driving new investments while maximizing shareholder value and strengthening global presence.

e& and Huawei Jointly Complete the Industry Leading 1.2T/Channel Trial in DWDM Network



Etisalat UAE e& announced that it has collaborated with Huawei to complete the trial of 1.2Tbps/channel in United Arab Emirates (UAE). This achievement is a major industry milestone in driving down the cost per bit of telecommunications networks. The trial showcased the ability of fiber networks reaching the overall capacity of single fiber transmission up to 96Tbps. The 1.2Tbps/channel technology will address etisalat by e&'s growing demand of capacity with the current new shift towards online digital behaviors, cloud-based business services, enhanced Home broadband and 5G services. Dense wavelength division multiplexing (DWDM) is an optical fiber multiplexing technology that is used to increase the bandwidth of existing fiber networks. etisalat by e& is again leading the optical industry with latest innovative solution and early technology adoption. This accomplishment is particularly significant in emphasizing the promise to deliver the best-in-class and the most advanced robust network in UAE. Based on the 1.2Tbps/channel adoption, etisalat by e& optical network will be able to take a leap closer to attain an innovative agile transmission network model that can rapidly adapt to external changes

and respond to customer business requirements. This trial leverages Huawei's latest 1.2Tbps/channel optical module by using the unique second-generation channel-matched shaping (CMS) technology, including a series of advanced transmission algorithms such as Nyquist-shaping, Transmit pre-compensation and SOP (state of polarization) tracking. The result of the trial demonstrated the excellent transmission performance, while achieving the optimal spectrum efficiency. Combined with Super C-band and Super L-band solution, it will provide the industry's largest single-fiber capacity of 96Tbps. Marwan Bin Shakar, Senior Vice President, Access Network Development at etisalat by e&, said: "The successful trial of 1.2Tbps/channel with Huawei is a result of our continuous efforts to deliver enhanced customer experiences by pushing the boundaries of what is possible as a digital telco. This has resulted in etisalat by e& taking the lead in building one of the most advanced networks globally and using industry leading technology to deliver superior network services to our customers across UAE. With 1.2Tbps/channel solution, we are able to deliver more data by every wavelength, and build

an optimal cost-per-bit optical network for best-in-class customer experience. This trial will further strengthen our efforts in maximizing value for customers and bring positive change to their lives in the age of digitalization." Victor Zhou, President of Huawei's Transmission Network Domain, said: "We are glad to work with etisalat by e& to complete this 1.2Tbps/channel trial. We will continue to collaborate with etisalat by e& to achieve more innovations by Huawei ultra-high-speed OTN solution, and build a high-quality, reliable, and scalable transmission network, helping Etisalat by e& to achieve business success." Etisalat Group has changed its brand identity to e&, effective on February 2022. Its strategy aims to accelerate growth through the creation of a resilient business model represented by Group's main business pillars. The telecoms business currently continues to be led by etisalat by e& in the Group's home market and e& international markets, upholding the Group's rich telecoms heritage, bolstering the strong telecoms network and maximizing value for the Group's various customer segments. Ramping up the digital services for individuals to elevate their digital-driven lifestyle, e& life brings next-generation technologies through smart platforms in entertainment, retail and financial technology. e& enterprise focuses on maximizing value through its end-to-end solutions in cybersecurity, cloud, Internet of Things (IoT) and Artificial Intelligence (AI), as well as deploying mega projects, in order to enable the digital transformation of governments, large-scale enterprises and corporates. e& capital allows the Group to focus its efforts on driving new investments while maximizing shareholder value and strengthening the Group's global presence.

Etisalat (Now Rebranded as e& at The Group Level) Named Most Valuable ‘Emirati’ Brand of the Year

Etisalat, which evolved as e&, has been named the most valuable UAE brand of the year 2022, topping the list across all categories in the UAE by Kantar BrandZ, the world's leading marketing data and analytics company. Kantar's annual local and global brand valuation rankings combine and analyze financial data with in-depth research into consumer opinion of brands. They identify the most valuable UAE and Saudi Arabia's brands and provide the most definitive and robust ranking of consumer brands in the country. The Kantar BrandZ study includes the opinions of over 30,000 consumers in the UAE and Saudi markets, looking at 695 brands in 53 categories. Etisalat received this recognition for its brand value for leading the UAE's league table with a brand value of USD 11.84 billion, showing a value growth of 129 per cent between 2020 and 2022. As part of its growth transformation journey, the group rebranded in 2022 to e&, to reinforce its position as a global technology and investment conglomerate that digitally empowers societies. The brand was also ranked fourth in the region in the overall Top 30 UAE and Saudi brands, ahead of other well-known UAE brands. "Being recognized as the leading Emirati brand and the most valuable brand in the UAE emphasizes our progressive outlook and aspirations in transforming Etisalat into e&, a global technology and investment conglomerate. This reflects the growth mindset that drives us to create a future-ready business model and meet the growing digital needs of our consumers and enterprise customers," said Hatem Dowidar, Group CEO, e&. "Our relentless efforts to remain customer-centric and pushing the boundaries by investing in futuristic technologies and solutions to enhance the overall experience have contributed to reaching such a milestone. We are also grateful to the UAE leadership, which has always been at the forefront of innovation in elevating the ICT sector in the country and

staying future-focused to empower communities and enrich lives." Etisalat Group has changed its brand identity to e&, effective on February 2022. Its strategy aims to accelerate growth through the creation of a resilient business model represented by Group's main business pillars. The telecoms business currently continues to be led by etisalat by e& in the Group's home market and e& international markets, upholding the Group's rich telecoms heritage, bolstering the strong telecoms network and maximizing value for the Group's various customer segments. Ramping up the digital services for individuals to elevate their digital-driven

lifestyle, e& life brings next-generation technologies through smart platforms in entertainment, retail and financial technology. e& enterprise focuses on maximizing value through its end-to-end solutions in cybersecurity, cloud, Internet of Things (IoT) and Artificial Intelligence (AI), as well as deploying mega projects, in order to enable the digital transformation of governments, large-scale enterprises and corporates. e& capital allows the Group to focus its efforts on driving new investments while maximizing shareholder value and strengthening the Group's global presence.

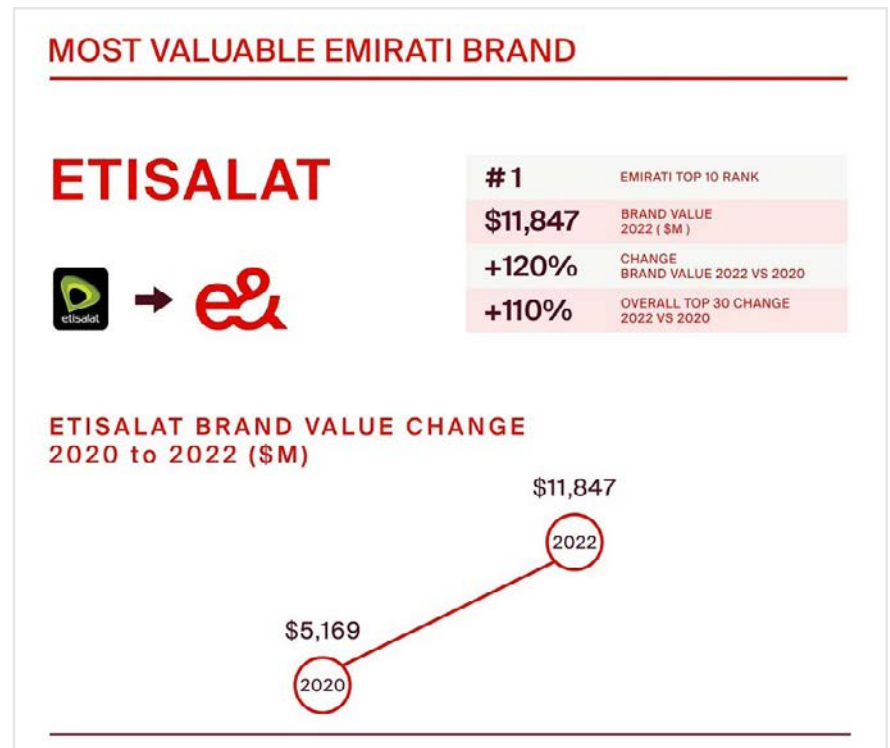

e& Boosts Stake in Vodafone Group to 11%

UAE-based e& (formerly Etisalat Group) has announced that it has increased its stake in British telecoms giant Vodafone Group. In a press release regarding the development, e& confirmed that it now holds 11.0% of Vodafone Group's issued share capital (excluding treasury shares). No financial details of the transaction that

boosted the shareholding were disclosed, however. e& said its rationale for boosting its stake in Vodafone Group was unchanged from when it first announced making a strategic investment in the company, with that being 'to gain significant exposure to a world leader in connectivity and digital service at an attractive

valuation'. In May 2022 e& announced that, via wholly owned subsidiary Atlas 2022 Holdings Limited, it had acquired 2.766 billion shares in Vodafone Group, representing 9.8% of the latter's issued share capital (excluding treasury shares), at a cost of around USD4.4 billion.



Mobily Achieves 3.8Gbps in 5G SA Trial Using CA

Saudi telecoms operator Mobily has achieved a maximum download speed of 3.8Gbps on its 5G Standalone (SA) network using tri-band CA (3C), in collaboration with Nokia. The companies claim this is the first experiment of its kind in the Middle East and Africa, where three frequencies are integrated within the medium-range

spectral band with a width of 100MHz for each band separately, totaling 300MHz. As a result of this experiment, Mobily will be able to add 100MHz to its 5G network. Mikko Lavanti, head of Mobile Networks at Nokia MEA, said: 'Together we have successfully demonstrated that 5G Carrier Aggregation plays a key role in improving 5G network

coverage, capacity, and performance to meet the growing consumer and business demand for advanced mobile services. The trial is further strengthening the long-term relationship between Mobily and Nokia as well as improving the global ranking of Saudi Arabia and Mobily in providing distinctive 5G services'.



Omantel Launches Middle East's First 400GbE DCI Service with Ciena

Oman Telecommunications Company (Omantel), Oman's first and leading integrated telecommunications services provider, has announced the launch of a 400GbE DCI service utilizing Ciena's Data Center Interconnect solution. The service is designed to meet the rapidly rising connectivity demands of Omantel's wholesale, cloud and content provider customers while delivering a superior customer experience through optimized performance. Omantel's 400GbE DCI service runs on Ciena's 6500 Packet-Optical Platform powered by WaveLogic 5 Extreme coherent optics and is managed by the Manage, Control and Plan (MCP) domain controller. The Ciena solution gives Omantel the ability to deploy 100G and, for the first time, 400GbE DCI connectivity over wavelengths up to

800Gb/s to accommodate increasing network traffic. "Our vision is for Oman to be the leading gateway to the region and beyond. We are bringing this mission to life, and a recent example is our new 400GbE data center interconnect service that we developed with Ciena. At Omantel, considering the numerous benefits on technical, commercial and social levels, we acted upon a clear strategy for data centers by partnering with Equinix, the world's digital infrastructure company, to launch MC1, the premier carrier-neutral data center in MENA. We are now taking the next step by introducing an innovative new DCI service, the first of its kind in the region," said Sohail Qadir, Vice President of Wholesale at Omantel. He added, "Crucially, we were able to launch the service sustainably—without deploying

additional platforms—doubling wavelength transmission capacity from 400G to 800G and improving overall fiber capacity leveraging our existing footprint. What this means for our customers is faster delivery of on-demand cloud applications and content with the highest quality." Virginie Hollebecque, Vice President and Leader of EMEA, Ciena, said: "With a flexible, scalable network foundation from Ciena, Omantel is able to get ahead of the growing demands on today's networks and provide its customers with unrivaled connectivity by way of its DCI service." Omantel and Ciena continue to work together on various levels to introduce advanced products based on the latest technologies in the industry. The collaboration has resulted in innovative products that reflect the leading role of both companies in the wholesale domain.

Omantel and ETCO Give a Major Boost for the Digital Economy of the Sultanate of Oman in the Space Sector

Omantel, the leading provider of integrated communications and technology solutions in the Sultanate of Oman, announced the signing of a partnership agreement with the international emerging technology company "ETCO" aimed at providing satellite image data analysis services for the Cube Satellite (Aman Sat). The agreement was signed by Dr. Ghalib bin Saif Al Hosni, Chief People Officer at

Omantel, and Eng. Abdul Aziz Jaafar, the Chief Executive Officer of ETCO. Based on the terms of the agreement, which was signed at the Cornwall Spaceport in UK, Omantel will contribute to this project with its technical expertise in information technology and digitalization as a technology partner to Aman Mission. Commenting on this event, Eng. Aladdin Baitfadhil, Chief Commercial Officer at

Omantel, said, "This strategic partnership with ETCO will enable Omantel to expand its digital services and support pioneering investments in the satellite image data sector, especially as Omantel owns artificial intelligence solutions, Internet of Things and its relevant technologies. Thus, satellite image analysis services come to complement these solutions and will provide a qualitative addition to the digital



services we provide, especially those related to the space field, which allows data analysis and supports scientific research projects in space sciences and much more. We, at Omantel, always support national institutions and vital projects for the benefit of the national economy and society". In turn, Eng. Abdul Aziz Jaafar, the Chief Executive Officer of ETCO, said, "We are pleased to sign this agreement with Omantel to complete its technical partnership in Aman mission and to expand our commercial operations in the space sector so as to provide satellite

image data to customers in the Sultanate of Oman and the region. Therefore, we seek from this partnership to transfer knowledge, technologies and involve national competencies by engaging in space-related industries and technologies. It is worthy stating that we have started our projects in the space sector with a number of global partners, and today we are proud of this national partnership with Omantel as it is a cornerstone for achieving the national goals of the Sultanate of Oman to create an interactive digital economy with the latest developments in the advanced

technology sector." "Aman Sat" satellite – which is owned by the Omani company "ETCO" - will be launched by the American company "Virgin Orbit" from Cornwall Spaceport in the United Kingdom, and it will provide several services including environmental monitoring images of coasts and nature reserves, images of weather readings, tracking climatic phenomena, marine and port monitoring images, urban and structural planning maps, oil and gas infrastructure management, vegetation cover images, water resources monitoring images, and insurance services images. Accordingly, the importance of operating this satellite lies in the fact that it is the first national satellite in the category of cubic satellites dedicated to capturing space images through ground stations to meet the needs in the Sultanate of Oman and the region in the space sector, along with the focus on strengthening local capabilities in analyzing satellite image data and supporting national competencies in the local engineering and scientific sectors in the relevant sectors and continue transferring the latest knowledge to them, in addition to reducing the costs for the sectors benefiting from the satellite image analysis services, where these images can be used for environmental inspection and increase agricultural efficiency, maps of all kinds, infrastructure management, oil, gas, mining , and renewable energy services.

Omantel Tops 5G Utilization in the Middle East Region with 5G for Fixed Wireless Access

After three years of relentless efforts across the nation, Omantel’s 5G now accounts for more than 60% of the total wireless access traffic on its network - making it the first operator in the Sultanate of Oman to reach such figures in 5G deployment and have positioned the company as a leader among the best 5G network operators in the region. Commenting on the achievement, Eng. Aladdin Bait Fadhil, Chief Commercial Officer at Omantel, said, "Our sustained efforts are bearing fruits and I am glad that more people throughout the Sultanate of Oman are now connected through our state-of-the-art 5G network. We are keen on accelerating our progress to take 5G



deployment miles ahead, and we are getting future-ready by bringing the most advanced technologies to the nation.” Omantel was the first operator in the Sultanate of Oman to commercialize 5G services, after leading the commercializing of the FWA and eMBB (Enhanced Mobile Broadband) services, significantly expanding all basic 5G outdoor coverage in major cities of Oman in 2022. Omantel is proud of its leadership of the 5G market in the Sultanate of Oman and for being one of

the leading regional 5G operators. Omantel is engaged with vertical industries and partners to expand the industry's digital transformation. During last year's GITEX, Omantel along with Hutchison Ports Sohar and Huawei collaborated to successfully launch the use case of 5G smart port in the Sultanate of Oman. This was the first 5G application in the field of ports in the Middle East region. Omantel is also using 5G to take cloud gaming to the next level. It recently joined hands with

NVIDIA and Zain to launch the powerful cloud-based GeForce Now for its home broadband customers. Gamers can just use GeForce Now and play online by connecting to their favorite gaming stores/platforms like Steam, Ubisoft and Epic Games. Omantel's focus is to take the user experience to higher levels, in terms of network performance, service provisioning channels, and after-sales care that builds market competitiveness through user experience leadership.



Zain Awarded the 'Best Diversity & Inclusion Strategy' PR at Informa Connect Future Workplace Awards 2022

Zain, a leading mobile telecom innovator in seven markets across the Middle East and Africa, has been recognized as having the 'Best Diversity & Inclusion (D&I) Strategy' in the Middle East at the Future Workplace Awards 2022, held in Dubai on 15 November, organized by the UK based Informa Connect, a member of the FTSE 100. Zain also won the award for "Best Women Development & Leadership Program" at the gala event, solidifying the company's reputation as being one of the most progressive and inclusive companies to work for. Future Workplace Awards (formerly known as Middle East HR Excellence Awards) showcases the best human resources (HR) talent in the Middle East and honors HR professionals in government and the private sector for their outstanding contributions in creating a high performing workforce for the future. Zain operates one of the most comprehensive D&I programs of any organization in the Middle East, which is now in its fifth year. Since its introduction, Zain's D&I initiative has become a key part of the fabric of the company, transforming how it hires, plans for succession, develops its people, and ultimately creates a vibrant and inclusive culture. The program focuses on six key pillars: Gender Diversity (WE); Disability Inclusion (WE ABLE); Youth Empowerment Initiatives (ZY); Innovation & Entrepreneurship (Zainiac); Employee Well-being (BE WELL); as well as mentoring (REACH). Zain Group Chief Diversity & Inclusion Officer, Maryam Saif commented, "To be recognized as an award-winning Diversity and Inclusion team is testament not only to how much we believe in our purpose, but how relentless we are to push for change within Zain. By nurturing a diverse and inclusive culture, through a series of carefully crafted programs and initiatives, we are beginning to observe significant evolution internally. We seek to harness the power of our differences to position Zain as a global catalyst for change." Zain's internal agenda seeks to promote innovation from within, with the ZY strategy based on critical thinking, creativity, and collaboration. Through Generation Z programs, Reverse Mentoring, and ZY Leadership Development initiatives, Zain's priority is to prepare young leaders for the future of work. Wellness and inclusion are vital and to truly live its values and deliver on the promise of becoming a fully accessible and inclusive organization, Zain's BE WELL and WE ABLE pillars



aim to deliver on this. With respect to women development and leadership, Zain set a target to have 25% women in leadership roles against a background of just 14.5% when the program was first introduced. Our focus for Women at Zain is succession, development, and leaders who will role model behaviors for entry level women in tech. Thanking the judging panel of the Future Workplace Awards 2022 for the recognition of Zain's efforts in the important areas of diversity and inclusion, Ms. Saif added, "Zain will continue investing in its people as upskilling staff, mentoring, and guiding them, allowing them to feel part of something that is greater than themselves, and appreciating their individualism and talents, all help build strong workforces which organizations can ultimately harness and benefit from." Zain's values, of Heart, Radiance and Belonging are ingrained into the company and the culture. It was imperative to integrate the strategy into the DNA of the company for it to be effective and thus Diversity & Inclusion at Zain is closely intertwined with these values, enabling the company to implement its programs and initiatives effectively. The two prestigious D&I awards follow Zain's recent recognition by Forbes magazine as Best Employer in Kuwait and among the top-10 companies to work for in the Middle East.

Zain Ranked Best Employer in Kuwait and Among Top-10 Companies to Work for in Middle East by Forbes

Zain Group, a leading mobile technology innovator in seven markets across the Middle East and Africa was included in the global list of "Best Employers" compiled by the renowned Forbes magazine. Zain was identified as the Best Employer in Kuwait as well as one of the top-10 employers across the entire Middle East. Forbes compiled its sixth annual World's Best Employers list, surveying 150,000 full-time and part-time workers from 57 countries, employed by multinational companies and institutions to determine which ones excel in areas including corporate impact and image; talent development; gender equality; and social responsibility. Along with higher salaries, better benefits and advancement opportunities, and work/life balance, employees say purpose-driven work is a top priority. Survey participants were asked to rate their willingness to recommend their employers to friends and family and to evaluate other employers in their respective industries that stood out either positively or negatively. This year's list comprises 800 companies that received the highest scores. Multiple Human Resources initiatives including talent development, as well as Sustainability, and Diversity and Inclusion programs remain strategic focus areas in Zain's work culture, as they are part of the company's ethical commitment to aligning with the UN's Sustainable Development Goals to create positive economic, social, and governance impacts in the communities Zain serves and beyond. Bader Al-Kharafi, Zain Vice-Chairman and Group CEO commented, "As a purpose-driven technology leader in the region, our contribution to digital transformation, talent development, and proactive workplace initiatives are key to better customer experience and socio-economic progress. Embedding sustainability and meaningful connectivity in every aspect of our business, Zain is dedicated to its '4Sight' strategy of working consistently towards developing the mobile telecommunications and ICT ecosystem centered on a vision of diversity and inclusive development, aligning to the aim of the UN's Sustainable Development Goals of leaving no one behind." Al-Kharafi added, "As we continue to grow and adapt to foster a diverse and inclusive workforce, Zain has always insisted that its people are the company's greatest single differentiator, and we take pride in our ongoing efforts to support and empower our employees. Our Diversity and Inclusion program has become a key part of the fabric of the company. Transforming how we hire, plan for succession, and develop our people ultimately creates a vibrant and inclusive culture that values employees' unique abilities and contributions." Zain's highly impactful, and often pioneering employee-focused initiatives motivating its people include: D&I: Zain's Diversity and Inclusion program has proven extremely successful in motivating employees as one of the most progressive initiatives of any entity in the region, with programs focusing on WE, Zain's gender diversity initiative; WE ABLE, the disability inclusive program; ZY, the youth development program; ZAINIAC, the internal innovation drive; BE WELL, the mental health program and Reach, the mentoring initiative. The overall program demonstrates Zain's company values and increases employee engagement and creativity, bringing it closer to all stakeholders. Digital Innovation: Zain's strategy of digital transformation is based on investing in new business verticals such as ICT and Digital



Infrastructure, including ZainTech, Data centers and Tower entities, as well as in 4G, 5G, and FTTH networks to offer more innovative customer-focused, and B2B services to government, business, IoT, and smart city sectors, bolstering the digital economy. Moreover, the Group API platform, 'Dizlee', continues to grow exponentially, offering rich entertainment content and gaming, with Zain making substantial progress in various fintech and esports services. Human Rights: Since inception, Zain has been deeply committed to the basic principles of human rights, respect for the rule of law and the well-being of society, making it an employer of choice. Conducting business in a fair, transparent, and equitable manner, and proactively engaging with various stakeholders, the Board of Directors recognizes it has the responsibility to uphold respect for human rights and contribute towards positive systemic change in the communities in which the company operates. Notably, Zain tracks the effectiveness of its policies through engaging frequently with employees, suppliers, the general public and third-parties likely to be affected by such procedures, as well as ensuring mandatory compliance with the Zain Group Supplier Code of Conduct throughout its ecosystem. The many purpose-driven programs implemented across all facets of Zain's day-to-day business operations are positively impacting the level of employee satisfaction and attracting high caliber talent to the company across its footprint.

Zain Scoops 7 Awards, Including 'Best Brand'

Zain announces that its brand has been identified as the 'Best Telecom Brand' in the Middle East for the third consecutive year during the Telecom Review Summit Excellence Awards gala ceremony held recently in Dubai. The 'Best Brand' accolade confirms the ongoing impact of Zain's investment in 5G network upgrades and unique digital offerings that enhance the customer telecom experience, ground-breaking media campaigns, focus on corporate sustainability and diversity and inclusion (D&I) initiatives, making the company one of the most respected and recognized corporate brands in the region, since its introduction in 2007. Distinctively, Zain Saudi Arabia was recognized for its successful transformational and digital growth in recent years that has taken the operation to new heights. The operation was awarded four prestigious awards for the 'Best CSR Initiative'; 'Best Standalone 5G Network'; 'Best Cloud Provider'; and a Global Merit award for the Chief Technology Officer for his efforts in the successful 5G rollout that placed the Kingdom on the 5G world map. ZainTech received two awards for the 'Best ICT Investment' for its agreement to acquire BIOS Middle East, a managed cloud service provider and 'Best Enhanced Service Provider' for its Drone-as-a-Service offering. ZainTech was established in October 2021 with the primary aim to offer enterprises and governments across the region a unique, one-stop shop across the full stack of ICT services. The two awards are testament to the ongoing progress that the new entity has attained in signifying itself as a key player in this lucrative and fast-growing sector. Telecom Review is a leading industry publication, and the multiple awards recognize the outstanding performance of Zain's brand and enhanced customer experience across its markets, reflective of the company's significant investments and pioneering innovation in digitalization, better serving individuals, enterprise and government customers across the region. In its 2022 global ranking, Brand Finance, a leading valuation and strategy consultancy based in London, valued the Zain brand at USD 2.4 billion, a 9.6% increase year-on-year. Zain's marketing campaigns



on various media channels across the region have captured the hearts and minds of millions of people. Zain's Ramadan, Eid and other television commercials throughout 2022, for example, received an impressive 250 million views on YouTube, indicative of the brand power of Zain. Today, Zain Group and its local operations boast over 13 million fans on Facebook, more than 7 million followers on Twitter, 2.6 million on Instagram and 750,000 on LinkedIn, totaling more than 23 million fans and followers across its social media footprint. Zain continues to introduce new, dynamic services to its customers, evident by the expansion of Zain's digital services and API platform 'Dizlee' in offering over 50 unique and appealing content and gaming services, as well as the growth of Zain Esports that has attracted over 30,000 gamers and 50 million social media views since its establishment in November 2020. In the Fintech space where Zain provides far-reaching benefits to needy and vulnerable groups across

various operations, the company's market leadership saw it increase its customer base by 34% and revenue by 231% year-on-year in 2022, processing approximately US\$ 3 billion transaction value annually. Sustainability and good corporate governance lie at the heart of every aspect of Zain's day-to-day operational activities in pursuing its sustainability agenda and supporting the communities it serves. Zain is passionate about curbing the effects of climate change, children's rights and safety, capacity-building, education, socio-economic development, and environmental stewardship. The company's focus on environmental, social and governance (ESG) indicators, ensures that ESG issues are integrated into the business strategy, and Zain's Corporate Governance structure and sound practices in providing accurate, timely, and actionable information in a transparent and accountable manner has won the confidence of local and global investors.

Zain Wins Top Titles at 10th Kuwait Creativity Award

Zain, Kuwait's leading digital service provider, was recognized with four accolades during the tenth Kuwait Creativity Award in recognition of its notable track of media productions and digital campaigns, becoming the most recognized company in the Award's 10-year history. The announcement was made during the special event held under the patronage of H.E. Minister of Information and Culture and Minister of State for Youth Affairs Abdulrahman Al Mutairi, attended by Undersecretary of Kuwait's Ministry of Information Mohammed Bin Naji and a distinguished group of actors, artists, and public figures from the local and regional media scenes. Zain received a total of four awards: Direction Award in recognition of its Ramadan TVC, Creativity Award in recognition of its Eid TVC, Entertainment Programs Excellence Award for its Eid

Play Zain Forever, and the Public Relations Award presented to Chief Corporate Affairs and Relations Officer Waleed Al Khashti. Zain was awarded with the Direction Award for its Ramadan 2022 TVC, produced by Joy Productions, in recognition of Director Samir Aboud. The TVC featured Lebanese star Nadine Nassib Njeim and Bahraini star Hala Al Turk, and was written by Heba Meshari Hamada, with music by Ehab Abdelwahed, music arrangement by Wissam Abdelmonem, and sound engineering by Amit Nathan. The TVC has yielded over 16 million views since its launch. Zain received the Creativity Award in recognition of its much beloved Eid 2022 TVC, produced by Joy Productions and A One Productions, directed by Ahmed Abdulwahed, music production by Music Yard, music composition by Ehab Abdulwahed, lyrics by Menna Al Keiy, music

arrangement by Wissam Abdelmonem, and sound engineering by Amit Nathan. As of today, the TVC has a staggering 184 million views. Zain was also awarded with the Entertainment Programs Excellence Award for its Eid 2022 Play Zain Forever, which made a comeback after a two-year pause due to the COVID pandemic. Zain celebrated the tenth year of producing Eid Al Fitr theatrical productions with the debut of Zain Forever, which drew joy and happiness on the faces of children and their families throughout the Eid holiday at Arena Kuwait, 360 Mall. The show centered around the story of a little girl and her friends adventuring through challenges and surprises via beautifully made art scenes like snowy fields, green forests, and deep oceans. The play featured stunning musical pieces and child-focused lyrics, and was written by Heba Hamadah, composed by Haneen Hussain, arranged by Ammar Al Bunni, and directed by Samir Aboud. The annual event, hosted by the Arab Media Forum in collaboration with the Kuwaiti Media and Communications Society and the Integrated Media Academy, witnessed the presence of many media organizations, public figures, creative people, and media professionals from across the Arab world. This recognition comes in light of Zain's distinguished advertising and media efforts, and further showcases the company's role as a leading private sector company launching distinguished marketing and advertising campaigns all year round. Zain will continue supporting this very important field which carries significant and informative messaging to the public at large and the communications world as a whole, whether through traditional or modern media tools.



Zain Plans to Invest US\$800 Million in Sudan in Next Five Years

Kuwaiti-owned telecoms company Zain Group has earmarked investment of US\$800 million for its Sudanese operations over the next five years, reports Sudan News Agency (SUNA). In a meeting with the President of the Transitional Sovereignty Council Abdul-Fattah Al-Burhan, Zain Group's Executive President and Vice Chairman of the

Board of Directors Badr Nasser Al-Kharafi said that the firm will invest the funds in improving network and service quality, as well as the deployment of fiber-optic services. Al-Kharafi added that Zain will invest in digital services and digital banking services, stating that the company has begun procedures for obtaining a license

from the Ministry of Communications and Digital Transformation. Zain Sudan is the country's largest mobile operator by subscriptions with a market share of 47.7% at 30 September 2022, ahead of South Africa-based MTN with 26.3% and locally-owned Sudatel (Sudani) with a 26.0% share of subscriptions.

Arthur D Little

Arthur D Little Launches Dedicated Team to Accelerate Transformation of Japanese Financial Institutions

Arthur D Little (ADL), a strategy consulting firm, has established a team dedicated to accelerating the transformation of financial institutions in Japan. The team will work closely with the firm's global finance practice to help clients of all sizes and business models in the financial services industry, including domestic and international banks, securities firms, insurance companies, and new entrants, transform themselves in a rapidly changing world. In "Disruption - Can banks strike back?", Global Finance Practice discusses the challenges facing traditional banks as new competitors emerge and the banking models that need to change and survive. The rise of digital natives and the entry of other industries into the banking industry are reshaping the landscape. However, the financial soundness and name recognition of existing banks cannot be built overnight. To ensure that this advantage is not squandered, we believe it is important to embark on fundamental reforms without fear of change, and we have identified six priorities for action.

1. Flexible setting of "battle plans" with a medium-term vision of the future (3-5 years) and formation of an ecosystem with different industries, including FinTech companies, to realize these plans.
2. One-stop customer understanding that maximizes data analytics, moving away from traditional perspectives such as attributes and purchase history
3. Promote organizational innovation, including incubation of start-ups, to fully benefit from accelerating improvements in finance-related technology
4. Align leaders who can find direction from an incomplete set of unrelated information, and build a diverse management team that can help drive change
5. Fostering a multifaceted organizational culture that promotes future change across the company without being limited by past successes
6. Developing strategic and consistent partnerships to meet diverse customer needs, without being fixated on achieving them on a

stand-alone basis in the own bank

Yoshiro Makita, a partner in the firm's Financial Services Practice in Japan, offers the following observations in response to this discussion. "The basis of competition in the financial services industry continues to change with the advancement and penetration of digital technology. However, the emergence of non-financial businesses with cutting-edge digital technology is creating new competitive dynamics for these strengths. As this paper discusses, there is a need to redefine their strengths in terms of creating new value for customers through collaboration with the competitive advantages of other companies and industries". ADL, together with its global network of experts, is committed to making an unparalleled difference for clients in financial institutions and related industries by combining a full range of solutions to meet the challenges and growth opportunities presented by changes in technology, regulation, and client needs.



AT&T, Amarillo Break Ground on New Fiber Network

AT&T and BlackRock Alternatives (BlackRock), through a fund managed by its Diversified Infrastructure business, have signed a definitive agreement to form a joint venture that will operate a commercial fiber platform. The newly formed joint venture – Gigapower, LLC – expects to provide a best-in-class fiber network to internet service providers (ISPs) and other businesses across the United States. Gigapower will serve customers outside of AT&T's traditional 21-state wireline service footprint with fiber access technologies in innovative and efficient ways. And AT&T will leverage its nationwide wireless sales capabilities to sell fiber to customers in Gigapower territories. "Now more than ever, people are recognizing that connecting changes everything" said John

Stankey, CEO of AT&T. "With this joint venture, more customers and communities outside of our traditional service areas will receive the social and economic benefits of the world's most durable and capable technology to access all the internet has to offer." "We are excited to form the Gigapower joint venture in partnership with AT&T, which will be serving as not only a joint owner but also the first wholesale tenant. We believe Gigapower's fiber infrastructure designed as a commercial open access platform will more efficiently connect communities across the United States with critical broadband services," said Mark Florian, Global Head of Diversified Infrastructure, BlackRock. "We look forward to partnering with Gigapower's highly experienced management team

to support the company's fiber deployment plans and shared infrastructure business model." Gigapower plans to deploy a reliable, multi-gig fiber network to an initial 1.5 million customer locations across the nation using a commercial open access platform. The Gigapower fiber deployment will be incremental to AT&T's existing target of 30 million-plus fiber locations, including business locations, by the end of 2025. Combined with existing efforts within AT&T's 21-state footprint, this capital efficient network deployment will advance efforts to bridge the digital divide, ultimately helping to provide the fast and

highly secure internet people need. This network expansion will also help spur local economies in each of the communities in which Gigapower operates. "Fiber is the lifeblood of digital commerce," said Bill Hogg, CEO of Gigapower. "We have a proven team of professionals building this scalable, commercial open access wireline fiber network. Our goal is to help local service providers provide fiber connectivity, create the communications infrastructure needed to power the next generation of services and bring multi-gig capabilities to help close the gap for those who currently are without multi-gig service." Following

close, AT&T and BlackRock will jointly own and govern Gigapower. AT&T does not expect to consolidate Gigapower's financial results but does expect to report its consumer subscribers served through Gigapower in Consumer Wireline business unit operational results. Any impacts to AT&T's 2023 capital investment or free cash flow forecast will be included in AT&T's 2023 financial guidance when it announces fourth-quarter 2022 results in January 2023. This transaction is subject to customary closing conditions, including regulatory approvals. Additional terms were not disclosed.

AT&T's Mexican 5G Network Reaches 31 Cities

AT&T Mexico has announced that its 5G footprint has reached 31 cities – one year after soft-launching the network in parts of Mexico City. New locations covered by the 5G network are listed as San Jose del Cabo, La Paz, Cabo San Lucas, Rosarito, San Luis Rio Colorado, Los Mochis, Tecate,

Nogales, Topolobampo, Huatabampo, Puebla and Queretaro. Nicole Rodriguez, VP and CTO at AT&T Mexico, commented: 'A year ago, we had the goal of turning on our network in 25 cities and today I am happy to announce that we have reached 31 cities with access to AT&T 5G.' The US-

owned cellco soft-launched its 5G network on 8 December 2021 in the Cuauhtemoc and Napoles districts of Mexico City. A full launch took place in May 2022, when AT&T switched on 5G technology in Mexico City, Guadalajara and Monterrey.

AT&T, Amarillo Break Ground on New Fiber Network

AT&T and city of Amarillo officials broke ground on a new state-of-the-art fiber network that will provide blazing fast internet to more than 22,000 customer locations in the city. AT&T Vice-President and General Manager – North Texas, Lynette Aguilar joined Amarillo Mayor Ginger Nelson and other community leaders at the Alamo Center to mark the \$24 million public-private project between AT&T and the city. "This groundbreaking signifies the start of new possibilities for Amarillo," said Mayor Nelson. "Technology is ever evolving, and our city deserves broadband that can handle the present and future demands. I'm glad that we were able to collaborate with AT&T and other community partners to find the best solution to connectivity for our residents." "Expanding our fiber footprint to connect underserved communities like Amarillo is necessary to our work to help close the digital divide," said Aguilar. "AT&T's history building communications in this state spans over 140 years. Our job is to continuously evolve with those demands to continue to serve our customers and



the community. That's what we're doing in Amarillo." "Amarillo's dedication to investing in fiber broadband is going to bring life-changing opportunities to our panhandle community," added Rep. Four Price. "Our schools, businesses, and families thrive when public officials and experienced internet service providers like AT&T come together to address the digital divide." The network, which is expected

to be complete in the next 12-18 months, will bring AT&T's hyper-fast fiber service to more residential and small business locations across the Amarillo area. One of the areas that will benefit directly from the new AT&T fiber network is the Barrio neighborhood, located in East Amarillo. The historic area, with a rich Hispanic heritage, has been the focus of a revitalization plan approved by the Amarillo City Council

in 2018 in conjunction with the Barrio Neighborhood Planning Committee. "The Barrio Neighborhood Planning Committee advocates for ways to strengthen our community and showcase our local talent," said Teresa Kenedy, President, Barrio Neighborhood Planning Committee. "This investment in connectivity by both the city and AT&T will bring countless opportunities for our residents to work, learn and play." AT&T Fiber is the fastest among major providers and offers symmetrical speeds of up to 5-Gigs on downloads and uploads.¹ Residents and businesses can learn more about AT&T Fiber at att.com/fiber and can sign up to be notified when

service will be available at their address at att.com/notifyme. AT&T is committed to connecting more Americans to reliable, high-speed broadband internet in several ways, including expanding and upgrading our network and participating in the federal Affordable Connectivity Program (ACP). The ACP provides eligible households with a benefit of up to \$30 a month (up to \$75 a month on qualifying Tribal lands) to reduce the cost of broadband service and can be applied to AT&T Fiber, where available. Or use it toward Access from AT&T, offering speeds up to 100Mbps for \$0 after the ACP benefit is applied. After you confirm your ACP eligibility, call us at 866-986-0963 or

visit us online to review your options and order service. Be sure to have your ACP application ID handy when you do this. AT&T Fiber, now delivering speeds of up to 5-Gigs, is truly internet that upgrades everything. Offering consumers the fastest internet¹ paired with network reliability, AT&T Fiber supports the powerfully interconnected home, work and family life. Our straightforward pricing eliminates annual contracts, data caps, equipment fees and price increases at 12 months, for all new customers. Plus, AT&T ActiveArmor SM internet security and our next-gen Wi-Fi are included at no additional cost.



Cisco Shares Key Trends Around Risk Reduction and IT Security

Cisco published the 2022 Duo Trusted Access Report under the motto "Logins in a dangerous time". The report analyzes data from 13 billion authentications on almost 50 million different devices worldwide made via Cisco Duo. Overall, the report shows that companies recognize and use multi-factor authentication (MFA) and passwordless technologies as important elements for risk reduction and IT security. "Digitization in the region and beyond, paves the way for a surge in cyber threats at all levels across organizations. With companies rigorously adopting hybrid and remote working models, indispensable business devices such as laptops and mobile phones are now more vulnerable than before. At Cisco we believe that business and IT leaders need to train, and ultimately, encourage the organization's workforce to implement MFA and passwordless technologies to ensure their assets are updated with additional layers of security," said Fady Younes, Cybersecurity Director, EMEA Service Providers and MEA, The report highlights the following important insights:

1. Passwordless adoption continues to rise: our data shows a 50% increase in the percentage of accounts allowing WebAuthn authentication and a fivefold increase in WebAuthn usage since April 2019.
2. Biometrics have stalled: The percentage of phones with biometrics enabled held steady at around 81% (a minor increase from 2021), indicating that progress towards biometrics across the board has stalled.
3. MFA continues to strengthen passwords: Multi-factor authentication holds strong while adding to the security of only traditional password usage. The number of MFA authentications using Duo rose by 38% in the past year.
4. Cloud usage continues to rise: An increasing number of authentications are attributed to cloud applications, with a 24% rise in the percentage of cloud applications in 2022.

5. Hybrid work and back to the office: Remote access authentications peaked in 2020 but have declined since then.

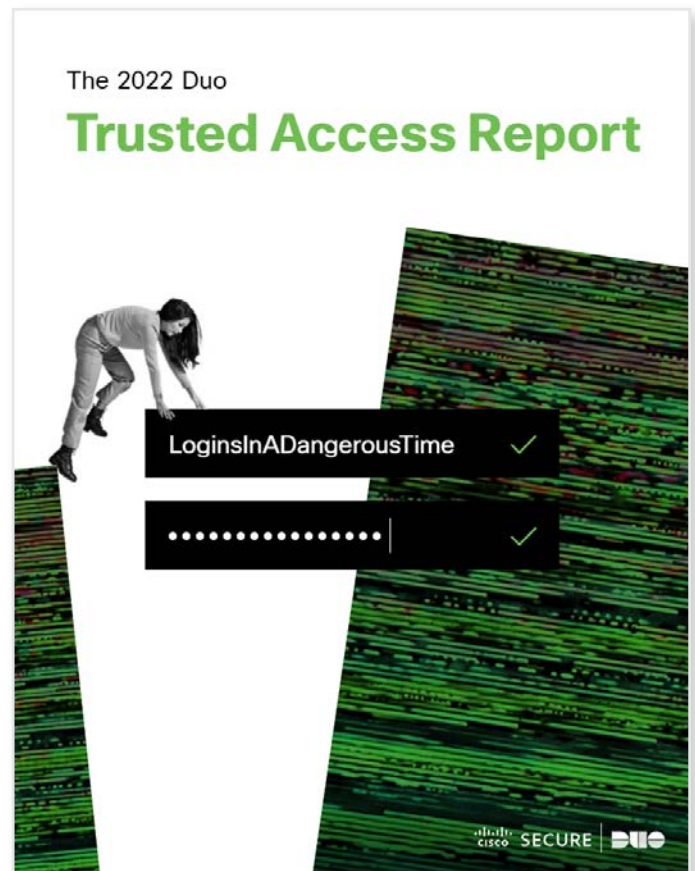

Cisco AppDynamics Launches Business Transaction Insights in AppDynamics Cloud for Observability of Cloud-Native Applications on AWS

Cisco AppDynamics announced major updates to its cloud-native observability solution AppDynamics Cloud. Business transaction insights combines business transaction monitoring with AppDynamics Cloud's continuous-context experience. This allows organizations to expand observability over cloud-native applications correlated with business context across their Amazon Web Services (AWS) environment and beyond. The AIOps-derived insights enable teams to observe applications the same way customers and end users experience them and quickly take action to optimize performance and remediate issues in near real-time. The new capabilities will initially support digital services, cloud-native applications, and workloads on Amazon Web Services (AWS). Cisco AppDynamics and AWS continue to empower organizations across the entire IT estate on their journey to full-stack observability. Modern cloud-native applications can be highly distributed and complex. Ops teams often have to rely on siloed, domain-specific tools to collect and interpret massive amounts of data generated by their technology stack during normal operations. As a result, they can struggle to deliver dependable digital experiences for end-user customers because they lack the correlated insights to identify how critical issues impact business outcomes. With business transaction insights, teams can leverage multiple streams of data drawn from OpenTelemetry™ and Amazon CloudWatch, all correlated to business context, and then optimize digital experiences at scale. They generate AIOps-driven alerts that allow teams to identify, prioritize, and resolve the most important issues that could impact the user experience and the overall business. A Cisco AppDynamics survey of 1,150 IT professionals revealed that 71% believe their organization will need to allocate resources toward observability of cloud-native applications and infrastructure. The addition of this new capability in AppDynamics Cloud gives technologists the simplicity and insights they need to streamline operations, increase business value of AWS products and services, and maximize current and future investments in areas including Kubernetes®, microservices, and other AWS infrastructure. "Business transaction monitoring is at the heart of our application performance monitoring strategy," said Vincent Lamonde, Director, Cloud Operations, Insurity. "As we innovate for the future and develop new cloud-



native solutions, it's critical to know that through innovations such as business transaction insights, Cisco AppDynamics can support our cloud-native landscapes as well as our traditional environments." "With AppDynamics Cloud, we are reimagining the cloud-native observability market," said Ronak Desai SVP/GM Cisco AppDynamics and Cisco Full-Stack Observability. "Cisco AppDynamics is enabling visibility of an organization's entire cloud-native landscape and generating insights based on an intelligent relationship model. With the addition of business transaction insights to AppDynamics Cloud, IT teams can now act with the information needed to make business-critical decisions and break down the new siloes that exist across their cloud-native monitoring landscapes. We are helping customers realize the vision of Cisco Full-Stack Observability and bringing genuine visibility, insight, and actions to their entire IT environment." "As organizations move their business to the cloud, it is critical to use solutions that enable them to understand their cloud environment and quickly identify meaningful data to optimize the customer experience," said Chris Grusz, General Manager of Worldwide ISV Alliances and AWS Marketplace, AWS. "With the introduction of business transaction insights for AppDynamics Cloud, customers can confidently evolve modern applications while taking better advantage of the agility, scalability and innovative cloud services that AWS provides."

Cisco Hails Largest-Ever Quarterly Revenue

Cisco CEO Chuck Robbins stated a trend of improved supply chains continued into its fiscal Q1 2023 (calendar Q3), which helped deliver the largest quarterly revenue in the company's history. On Cisco's earnings call, Robbins noted a redesign of many products and action taken over several quarters to alleviate supply chain issues yielded positive results. "We were encouraged by what we were seeing with modest improvement in certain component availability, as shortages continued to ease from last quarter." He noted the easing supply constraints was "now releasing software subscriptions that were sitting in backlog connecting to

unshipped hardware". Cisco has spent several years transitioning from one-time hardware sales to recurring software-based. Total software revenue increased 5 per cent year-on-year and software subscription 11 per cent. "Our business model is resilient with 43 per cent of our revenue now recurring, which is very important as we navigate the current macro environment," Robbins said. Cisco posted \$10.3 billion in product-related revenue, an increase of 8 per cent, though services was flat on \$3.4 billion. Overall revenue of \$13.6 billion was up 6 per cent, while net income of \$2.7 billion was down 10 per cent.

Cisco Brings More Flexibility to Hybrid Work In the Middle East

Cisco has announced new integrations between its Collaboration platform Webex and Apple technologies that help make hybrid work more flexible for people. As more businesses build long-term hybrid work strategies, Webex aims to provide in-office, remote and hybrid workers with the intuitive collaboration tools they need. The first integration is Mobile Camera Share, which allows iPhone and iPad users to share content from the rear-facing or front-facing camera via the Webex Meetings mobile app and annotate over what they are seeing. With next generation videoconferencing, users can write, draw, and add shapes, in real-time and simultaneously in their meetings. This industry-first innovation enables frontline workers to collaborate more effectively by leveraging the high-quality video capture capabilities of Apple devices. Architects, engineers, or construction workers can share job site progress with clients in real-time, instead of sending static images or screenshots. Another potential use case is for a technician to show the equipment in a factory, data center or field location with a help center team, who can write and draw instructions on the live feed to avoid any misunderstandings. Experts can see everything as if they were together in the room, noting their input onscreen where exactly corrections or changes should be made. "Today, people across



the Middle East expect flexibility when it comes to work. True hybrid work means being empowered to use your favorite devices to work seamlessly in the office, at home and everywhere in between. The latest collaboration solutions from Webex signify another step towards empowering workforces with greater choice and beyond the office," said Ahmad Zureiki, Director of Collaboration Business, Cisco Middle East and Africa. Apple's Continuity Camera is a new feature in macOS Ventura that enables Mac customers to use their iPhone as a webcam. Webex users can use the camera system on iPhone to unlock powerful video effects like Center Stage, Portrait mode, and

Studio Light. In addition, Webex supports Desk View in macOS Ventura, which acts like an overhead camera without the need for complicated equipment, showing the user's face and desk simultaneously — great for creating demos, instructional videos, drawing on paper, and more. These integrations are a testament to Webex's commitment to making collaboration even easier. Collaborating with Apple technology and putting the power of choice in the hands of hybrid workers builds on the momentum over the course of the year, with earlier announcements such as Webex for Apple iPad, Apple AirPlay on Webex devices, and Webex Meetings for Apple CarPlay.

Cisco Extends Spain Commitment with Design Centre

Cisco detailed plans to establish an engineering design center at an existing innovation facility in Barcelona, citing

benefits for European Union (EU) ambitions to take a leading position in global semiconductor research and production.



The US company noted the center will be its first of its kind in the EU, with a focus on creating next-generation chips. Cisco chair and CEO Chuck Robbins stated the company's semiconductor advances help "overcome the performance, economic and power-consumption limitations of current infrastructure". The center is being built under the framework of a Spanish economic transformation project centered on semiconductors and microelectronics. Cisco noted the move also contributes to an EU plan detailed in February to reduce the bloc's reliance on overseas chip supplies and strengthen its supply chain. The European Chips Act aims to double the EU's share of the global semiconductor market to 20 per cent by 2030.



CMI and MPT Collaborate to Advance Internet Data Center Solutions, Accelerating Africa's Digital Transformation

China Mobile International Limited (CMI) and Master Power Technologies (Pty) Ltd. (MPT) will collaborate to advance Internet Data Center (IDC) solutions in Africa and help boost the growth of digital economy across the region. The new partnership was confirmed with the signing of a memorandum of understanding at AfricaCom in Cape Town yesterday by Mr. Colin Wang, Managing Director of CMI Middle East and Africa Region, and Mr. Menno Parsons, Chief Executive Officer of Master Power Technologies (Pty) Ltd. Under the MoU, CMI and MPT will collaborate to support telecommunications companies, financial services firms and other enterprises to build and leverage the IDC solutions that underpin Africa's digital transformation. Mr. Wang said: "Investment in Africa's data center market is expected to grow by 15% to 2026, bringing greater processing power and speed to boost efficiency and growth for enterprises and organizations across the continent. We are honored to join with MPT to expand access to high-performance data centers for internet and cloud service providers and other companies driving Africa's digital future." Mr. Parsons said: "MPT shares CMI's belief that long-term relationship with clients and partners are the best way to deliver value and help create a better digital future for Africa. We are delighted to work with CMI to help build data center infrastructure that boosts Africa's digital ecosystem and promotes innovation and economic resilience and growth. We are confident that the first project under this collaboration will be launched soon. And we expect to deepen our partnership and expand our cooperation into other areas in the future." CMI is one of the global leaders in developing and delivering world-class data center, cloud and IoT solutions and has invested heavily in reliable, scalable and resilient network resources in Africa and beyond. Adding to its wealth of global resources, CMI is the only Asian operator participating in 2Africa, the world's largest subsea cable project. It will extend connectivity for Africa and the Middle East to Europe, Asia, and the world via its global infrastructure. In addition, CMI provides customized enterprise business services to customers worldwide. With its



comprehensive enterprise service portfolio – iSolutions - CMI helps enterprises navigate digital transformation and fuels their global expansion. MPT is a leading provider of dynamic power supply and integrated IDC solutions in Africa, with capabilities in IDC design, construction and operation. The company specializes in engineering power supplies, dynamic environment monitoring services and full-service IDC solutions, providing one-stop supply, implementation, and after-sales services. MPT serves customers throughout Africa, including large enterprises in telecommunications, media, finance and power industries as well as government agencies. Its professionalism and services have a high reputation in the industry. CMI is dedicated to providing customized IDC services and quality network connection services to enterprises around the world. Through the collaboration, CMI and MPT will work together to advance IDC solutions to achieve efficient convergence and agility, providing access with large bandwidth connectivity to customers.



Signing of the Final Agreement Relating to the Combination Between Eutelsat and OneWeb

Following the issuance by the employee representative bodies of their opinion on the proposed combination between Eutelsat Communications and OneWeb announced on 26 July 2022, the Board of Directors of Eutelsat Communications (ISIN: FR0010221234 - Euronext Paris: ETL, "Eutelsat") has approved the transaction. Consequently, Eutelsat and the main shareholders of OneWeb (Bharti, the UK Government, Softbank and Hanwha) signed on November 14th the final combination agreement. Completion of the transaction remains subject to the customary conditions precedent, in particular the approval by the relevant

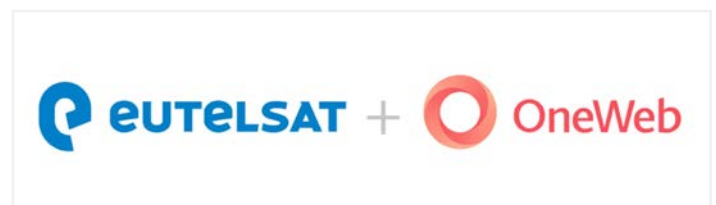

regulatory authorities. Given the currently expected timetable for review by these authorities, the Extraordinary General Meeting of Eutelsat shareholders called to approve the transaction is now

expected to be held in the second or third quarter of 2023. This possible change from the initially announced timetable should have no significant impact on the combined entity's financial outlook released in connection with the proposed combination. Upon completion of the transaction, the Board of Directors would be composed of 15 directors, including the Chairman and a Co-Chairman (Vice-President): the current

Chairman of Eutelsat (independent) who will be the Chairman of the future Board of Directors, the current Chief Executive Officer of Eutelsat, who will remain as such, two directors proposed by Bharti, including Sunil Bharti Mittal as Co-Chairman, one director proposed by Bpifrance Participations, one director proposed by the UK Government, one independent director representing Fonds Stratégique de

Participations, one independent director proposed by Hanwha, three independent directors proposed by OneWeb and four independent directors proposed by the Board of Directors of Eutelsat, three of whom are to be selected from among the current directors of Eutelsat. This would bring the number of independent directors on the Board to 67%.

Eutelsat and Tizeti Collaborate on Community Satellite Broadband

Satellite operator Eutelsat Communications has inked a deal with Nigerian wireless ISP Tizeti to jointly improve broadband penetration in Nigeria, particularly in underserved locations. The two companies will deploy Eutelsat's KA-band satellite connectivity, known as Konnect, to reach remote communities and provide fast and affordable internet services. The partnership will provide a complementary solution that leverages satellite broadband infrastructure and Tizeti's community Wi-Fi management platform to deliver a fast and affordable public Wi-Fi hotspot service, especially in remote areas that are difficult to reach by terrestrial broadband infrastructure. Tizeti's services are currently available in the states of Lagos, Ogun, Oyo, Edo and Rivers in Nigeria, but



it has also successfully launched in Accra and Tema in Ghana. Commenting on the collaboration, Philippe Baudrier, Eutelsat's General Manager of Connectivity for Africa, said: 'Eutelsat's ambition is to connect one million unserved people across sub-

Saharan Africa to high speed internet over the next five years and this partnership with Tizeti will help bridge Nigeria's digital divide and unlock the wealth of social and economic opportunities that the internet brings.'

Successful Launch of EUTELSAT HOTBIRD 13G Satellite

Eutelsat Communications (Euronext Paris: ETL) announced that EUTELSAT HOTBIRD 13G satellite was successfully launched into Geostationary Transfer

Orbit by American space launch provider SpaceX using a Falcon 9 rocket that lifted off from Cape Canaveral, Florida, USA at 1.22 am Eastern time on November 3rd

(corresponding to 5.22 am UTC and 6.22 am CET on November 3rd). The separation of the all-electric satellite occurred after a 35-minute flight and the spacecraft systems initialization was successfully completed over a period of 3 hours. EUTELSAT HOTBIRD 13G is the second of two satellites built by manufacturer Airbus Defence and Space to be placed at Eutelsat's flagship 13-degree East neighborhood position, replacing three older satellites. It is also based on the Eurostar Neo telecommunications satellite platform, developed under an ESA Partnership Project with Airbus designed to foster innovation and competitiveness in the European space industry. Once into orbit and positioned, the satellite EUTELSAT HOTBIRD 13G will, with its twin EUTELSAT HOTBIRD 13F launched on October 15th, reinforce and enhance

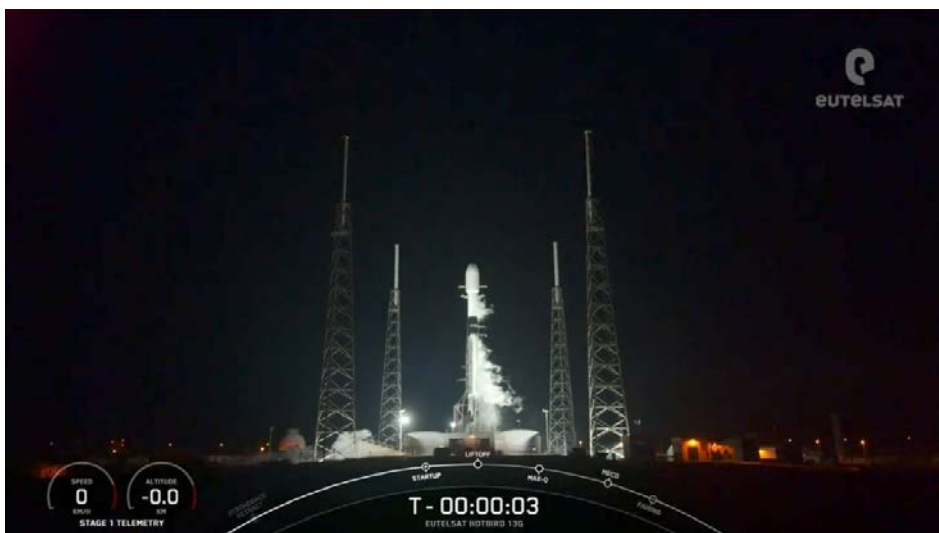

the broadcast of more than a thousand television channels into homes across Europe, Northern Africa and the Middle East. Moreover, the two satellites will offer advanced features in terms of uplink signal protection and resilience. In February 2021, Eutelsat was entrusted once again by the European Union Agency for the Space Program (EUSPA) to host the EGNOS GEO-4 payload, which is on board EUTELSAT HOTBIRD 13G. Eutelsat already operates the EGNOS GEO-3 payload on its EUTELSAT 5 West B satellite. EGNOS is the European Geostationary Navigation Overlay Service

that acts as an augmentation service to global positioning systems, to improve the reliability of positioning information. This is ensured by a crucial integrity message which is essential in aviation where the Global Navigation Satellite System (GNSS) alone does not satisfy strict operational requirements set by the International Civil Aviation Organisation (ICAO). It is especially important during critical aircraft flight stages such as the final approach. Other transport means including maritime and rail benefit from this EGNOS Safety of Life service. EGNOS also increases the

positioning accuracy for other applications, such as precision farming, geomatics, land management and maritime. Eva Berneke, Eutelsat Chief Executive Officer said: "EUTELSAT HOTBIRD 13G is now on its way to join EUTELSAT HOTBIRD 13F at our flagship 13-degree East position. We also look forward to completing the GNSS network for our European Union long term customer and partner, the EUSPA. My congratulations to the Eutelsat, Airbus and SpaceX teams for another successful launch into geostationary orbit."



Huawei Signs Global ITU Pledge to Help 120 Million People in Remote Areas Connect to the Digital World

Huawei has signed a global commitment to join the International Telecommunication Union's Partner2Connect digital alliance, which will bring connectivity to about 120 million people in remote areas in more than 80 countries by 2025. Liang Hua, Chairman of Huawei, announced the decision at the company's 2022 Sustainability Forum, Connectivity+: Innovate for Impact. The forum explored how ICT innovation could unleash the business and social value of connectivity and drive sustainability in the digital economy era. Speakers at the event included senior leaders from the ITU and United Nations, telecom ministers and regulators in Cambodia, Nigeria, Bangladesh, and Pakistan, and business leaders, partners, experts, and customers from China, South Africa, Belgium, and Germany. "It is clear connectivity alone is not enough. It must be affordable, the content must be relevant and in the local language, and users must have the skills to make best use of it," said ITU Deputy Secretary-General Malcolm Johnson. "Thank you to Huawei for their support of the Partner2Connect (P2C) Digital Coalition, and for their announced P2C pledges in the key areas of rural connectivity and digital skills." Siddharth Chatterjee, United Nations Resident Coordinator in China, called for "multi-stakeholder partnerships" of policymakers, the private sector, academia, and civil society to close "the sobering reality" of a digital



divide which excluded a third of the global population. "Our dynamic world urgently needs improved digital cooperation to capitalize on the transformational potential of technology to create new jobs, boost financial inclusion, close the gender gap, spur a green recovery and redesign our world to be more prosperous and inclusive," he said. "Now is the time to act". In his keynote address, Dr Liang stressed that access to a stable network was a basic requirement and right in the digital age. For many who remain unconnected, access to reliable connectivity would mark the first step towards transforming their lives. "Connectivity will be more than just a tool for convenient communications," he said. "Together with digital technologies like cloud and AI, connectivity will help

bring everyone into the digital world, and provide them with access to more information and skills, better services, and wider business opportunities. This will, in turn, drive further social and economic development." Cao Ming, President of Huawei Wireless Solution, said: "As an enterprise with the most complete ICT capabilities, Huawei integrates the full-technology innovation potential of equipment, sites, energy, transmission, and antennas to address the difficulties faced by traditional site deployment, such as high costs, restricted transportation, lack of power, and maintenance challenges. We have continuously upgraded the RuralStar and RuralLink solutions to extend quality coverage to remote areas, enabling more people, community hospitals, schools, local

governments, and small- and medium-sized enterprises to enjoy the same high-speed broadband connectivity experiences as those in cities". The RuralStar series solutions have provided connections for more than 60 million people in remote areas in more than 70 countries. The construction of optical broadband networks offers another important route to realizing a universal service. Huawei has proposed an innovative AirPON solution for areas with low population density, including remote areas. This solution

continuously reduces the footprint of equipment rooms, optical fiber installation costs, and network power consumption, while ensuring the rapid deployment of local communication networks. In Africa alone, Huawei has laid more than 250,000 kilometers of optical fibers, enabling 30 million households to access high-speed broadband. User experience has seen constant improvement. The average speed of home broadband already exceeds 30 Mbit/s, bringing smarter, faster, and smoother home network experience. As

ICT infrastructure continues to evolve, innovative technologies like cloud and AI are allowing those in rural and remote areas to enjoy the convenience of a digital world. Huawei Cloud has proposed the Everything as a Service strategy and made Huawei's more than 30 years of technical expertise and digital transformation experience available through cloud services. This means that access to Huawei's digital infrastructure capabilities on the cloud is now just as easy, affordable, and sustainable as water and electricity.

Huawei Addresses Cybersecurity Challenges Facing Emerging Technologies at Major Global Cybersecurity Summit in Oman



Huawei took part in the Arab Regional Cybersecurity Week 2022 in Muscat, Oman, from November 6 - 9, where it advocated for sustained collaboration to secure the digital world. Huawei called upon Arab nations under the Organization of Islamic Cooperation (OIC) to implement the OIC-CERT 5G Security Framework where the Network Equipment Security Assurance Scheme (NESAS) standard, the joint GSMA and 3GPP framework for the security evaluation of mobile network equipment shall be the fundamental security baseline. The Arab Regional Cybersecurity Week 2022 was organized by ITU-Arab Regional Cybersecurity Centre (ITU-ARCC) and hosted by the Oman Ministry of Transport, Communications and Information Technology through Oman National Computer Emergency Response Team (OCERT). It featured a series of co-hosted events, comprising the 10th Arab Regional & OIC-CERT Cyber

Drill, the 10th Regional Cybersecurity Summit, the FIRST & ITU-ARCC Regional Symposium for Africa and Arab Regions, the 3rd WiCSME Annual Conference and the 14th Annual Conference of the Organization of The Islamic Cooperation CERT (OIC-CERT), culminating with the 10th Annual Arab Meeting (ACCT) on 10 November 2022. Under the theme of "Cybersecurity Innovation and Industry Development", the event featured a stellar line-up of speakers, case studies, panel discussions and unique presentations that provided access to a wealth of industry-leading knowledge, sharing best practices and experiences, spotlighting trends, information exchange, cutting-edge insights and outlooks with actionable takeaways. During the event, Aloysius Cheang, Chief Security Officer, Huawei UAE, gave a keynote on the first day titled, "Addressing Cybersecurity Concerns in Emerging Technologies – Challenges and

Opportunities". He highlighted Huawei's commitment to building and maintaining an open and collaborative environment in the Arab world, where nations are binded together based on Islam as common faith, and therefore the OIC and the OIC-CERT shall be the platform of choice to usher in a new Islamic Golden Age in the Metaverse. Cheang also highlighted Huawei's commitment to the region, with our commercial membership in OIC-CERT and efforts to drive 5G security standardization, emphasizing our localized approach to supporting partners to enhance their network resilience in lieu of 5G and Cloud as critical pillars to embrace rapid digital transformation brought about by the pandemic. Cheang said, "5G faces security challenges and opportunities brought by new services, architectures and technologies, as well as higher user privacy and protection requirements. The industry needs to understand the requirements of diversified scenarios and better define 5G security standards and technologies to address associated risks." "NESAS, developed in accordance with security standard guidelines pertaining to vendors' product development and lifecycle processes, provides a security baseline to evidence that network equipment satisfies a series of security requirements. Together with the OIC-CERT 5G Security Framework, it offers a measurable and controlled environment with a Plan-Do-Check-Act guided actions for managing 5G security chaperoning rapid digital transformation needs of Arab nations," he added. Huawei believes cybersecurity is a shared responsibility that cannot be

addressed by one person, organization or nation alone. Huawei is ready to contribute our know-how and collaborate in an open, transparent and collaborative platform with all cyberspace stakeholders to ensure end-to-end cybersecurity that will be critical to realizing our vision of building a fully connected, intelligent world. OIC-CERT held its Global Awarding Ceremony on the sidelines of the event, where Huawei

Qatar was awarded the OIC-CERT Global Cybersecurity Award 2022 recognizing its efforts in cybersecurity excellence. Yang Ming, Head of Cybersecurity at Huawei Middle East, said “the award is a testament by OIC-CERT to Huawei’s contribution in cybersecurity innovation. Huawei has always taken cybersecurity as the company’s top priority and will continue to be a key contributor to cybersecurity

development in OIC-related countries in the future”. The Award is an initiative by the OIC-CERT to encourage international collaboration in the cybersecurity domain. It recognizes innovative cybersecurity projects from around the world, not bound by country or region that contribute to uplifting the OIC community welfare while promoting the digital realm.

Huawei and Tianjin Port Jointly Built a Driverless, Zero-Carbon “Vehicle-Cloud Synergy” Horizontal Transportation Solution

Huawei and Tianjin Port have jointly collaborated on a driverless, zero-carbon “vehicle-cloud synergy” horizontal transportation solution. Huawei built an intelligent horizontal transport system at the terminal of Section C in the Beijiang Port Area of Tianjin Port. The project has achieved Level 4 autonomous driving, enabling 76 Intelligent Guided Vehicles (IGVs) in a fleet to collaborate efficiently. Huawei used cloud-based centralized dispatching to increase port-wide efficiency. As hubs of global supply chains, ports play a critical role in promoting international trade. Traditional ports rely on humans to operate container cranes working under harsh working environments, are labor intensive and suffer from workforce shortages. These challenges hinder the rapid development of global sea transportation. Therefore, port automation and intelligent reconstruction have emerged as the industry’s overarching goals. Ports worldwide are going through a process of automation driven by the latest technologies like 5G, Cloud, and AI. A typical port deals with vessel arrivals and departures, shore-side operations, horizontal transport, yard operations, manual tractor-trailer transport, and gate operations. One of the key steps in port digitalization is automating horizontal transport that handles cargo within the port. Currently, conventional horizontal transport faces three major challenges: harsh working environments, safety risks due to driver fatigue, and inefficient manual dispatching. Huawei’s intelligent horizontal transport system has five key advantages. First, it offers global path planning. Huawei has designed a global path planning algorithm based on vehicle kinematics, which ensures that individual vehicles stay on their path. The algorithm enables multiple IGVs to make turns smoothly, whether traveling in one or both directions. This is the key to safe and efficient multi-vehicle cooperation. The solution also features dynamic short path planning on the cloud, responding to many terminal operations and adjusting tasks in real time. The second advantage is its high-precision positioning. Huawei uses BeiDou, 5G, HD maps, and roadside sensing assistance to assure high-precision lane-level positioning. As a result, 90% of quay cranes successfully align on the first try, significantly improving operational efficiency. Third, Huawei developed the MDC intelligent driving platform. The upgraded Huawei MDC offers automotive-grade assurance, including ultimate computing power and long service life. It also simplifies O&M by providing standardized hardware. The fourth advantage is core system integration. In addition to core



service systems such as TOS, Huawei’s intelligent horizontal transport system can quickly interconnect with other peripheral service systems. With Huawei’s intelligent charging dispatching algorithm, IGVs are charged at the best possible time, preventing interruptions to fleet services. Using Huawei’s intelligent intersection dispatching algorithm, ports can preset intersection traffic policies to ensure proper access by manual tractor-trailers and autonomous trucks. The fifth advantage is cloud-vehicle decoupling. Huawei decouples the cloud from vehicles through an open ecosystem. As a result, the solution can support a wide range of intelligent driving vehicle models, making it more cost-effective and easier to promote. In the event of an IGV fault, an operator can remotely take over operations. The service takeover rate for a regular autonomous driving solution is about 5% to 6%. For Huawei’s solution, it’s less than 0.1%, ensuring safer operations. IGVs rely on 5G networks. Huawei performs dynamic short-path planning to ensure that IGV paths never cross each other. This prevents collisions even if the network is abruptly disconnected. Intelligent, horizontal transport must meet three conditions. More than five operation lines must function simultaneously to support large vessels, while the system should be able to also manage large-scale fleets. Furthermore, it must support dispatching in complex port scenarios. Section C terminal in the Beijiang Port Area of Tianjin Port is the first smart terminal of its kind to deploy an intelligent horizontal transport system that performs large-scale, normalized operations.

Huawei launches Spark Program to Support Morocco's Startup Ecosystem

With the aim of initiating digital transformation in Morocco through support for the startup ecosystem, Huawei Morocco is organizing the national competition for the 1st edition of the Spark program, in December 2022, featuring the best participating startups. This competition will close with the awarding of prizes to the first three startups, selected by a jury, who will be awarded gratifying financial rewards. The winning startups will also have the opportunity to access technical and human resources, allowing them to reach their full growth potential. "Huawei is proud to organize this competition which aims to promote the entrepreneurial spirit in Morocco by encouraging project leaders to continue building promising startups and accelerating their digital transformation," said Jerry CUI, CEO of Huawei. Morocco. "We believe at Huawei that the key to sustainable digital development lies in an ecosystem made up of thriving and successful SMEs and startups. The Spark program initiated by Huawei allows startups to face technical challenges, in addition to helping them define viable go-to-market, customer prospecting and fundraising strategies., he



added. The Spark program is an ambitious international program that aspires to support and strengthen the technological capacities of startups operating in the various digital sectors so that they can develop their products and improve their growth. Developed by Huawei Cloud and supported by the Moroccan government, but also by several Huawei partners such as Technopark, AUSIM, MAScIR, Orange, ADD, MNF or even SMIT, the Moroccan edition of this Foreground is entirely dedicated to national startups operating in the field of new technologies (AI, Connectivity, Cloud, etc.). It helps companies to stimulate their sense of innovation, but also to promote their products and services so as to strengthen their competitiveness

and accelerate their growth, while taking advantage of business opportunities in the Huawei Cloud ecosystem. Huawei Spark is open to all Moroccan technology startups who want to push their limits, realize their dreams and reach their full growth potential. Under the Spark program, Huawei will provide recruited startups with ICT technology support and access to cutting-edge business know-how. As a reminder, the Huawei Spark program was initiated in Morocco last July during the Digitech Ecosystem Summit 2022. It testifies more than ever to the tenor of Huawei's commitment to help Morocco transform into a true "African digital hub". and nurture digital talent across the country.

Nexign Launches an OSS Solution to Centralize the Collection and Transformation of the CSP's Network Data

Nexign, a leading provider of BSS and digitalization solutions, launches a new OSS solution to centralize the collection and transformation of network data. Nexign Mediation represents a low-code platform that aggregates data from various network equipment and other sources. It lets communications service providers (CSPs) increase the security, speed, and flexibility of collecting and analyzing data streams for further use in billing and analytics. Nexign Mediation also allows quickly adding new data types, formats, sources, and consuming systems by expanding a set of ready-made plug-ins. The platform can process over 1.5 billion xDRs daily and supports 5G use cases. "Every day,

the operator's networks process billions of events: data comes from distributed network equipment, various locations, and in different formats. CSPs can take advantage of this information by using IT solutions that can quickly analyze large data volumes, enrich them, and deliver to consuming systems," comments Maxim Nartov, CBO of Nexign. "Nexign Mediation is a flexible and scalable platform that helps operators collect and analyze data and use it to resolve business tasks." The Nexign Mediation platform provides users with a drag-n-drop visual builder to create and run new data scenarios. At the same time, the built-in monitoring system helps track the platform's performance and

promptly notify the operator of identified problems. Nexign Mediation works with both offline and online streams. It can also be adapted to the client's needs during the implementation process. Nexign Mediation utilizes a low-code approach that minimizes the need for developer involvement for configuration and support. The platform also uses open-source databases to reduce TCO. Nexign Mediation complies with the 3GPP and TM Forum international standards and works with all types of networks, including 2G-5G, PSTN, VoIP, DSL, FTTX, and GPON. It supports continuous integration and delivery (CI/CD) pipeline, containerization, and scaling.



Nokia and John Nurminen Foundation Partner to Protect Biodiversity in the Baltic Sea

Nokia has announced a new collaboration with the John Nurminen Foundation to protect the Baltic Sea and support the regeneration of a healthy biodiverse ecosystem. This activity is in line with Nokia's recently announced enhanced Environmental, Social and Governance (ESG) strategy, as well as a broader longstanding commitment to advancing the role of technology in combatting climate change and minimizing environmental impacts. Nokia has committed to a three-year collaboration with the John Nurminen Foundation at a time when the Baltic Sea faces innumerable challenges. As a shallow inland sea, discharges of nitrogen and phosphorous from the surrounding area risk damaging eutrophication*, affecting oxygen levels and biodiversity within the local environment. Climate change can affect this cycle even further. The John Nurminen Foundation has been working since 1992 on improving understanding of the Baltic Sea and highlighting the risks that it faces, running a series of projects to improve the quality of the water, reducing the nutrient load, and associated environmental problems like eutrophication and nature loss. Nokia is focused on the role its products play in solving some of the world's most pressing challenges, using connectivity and digitalization to restore stalled productivity, provide inclusive access to opportunity and relieve pressure on the environment and natural ecosystems. 5G, sensors, analytics and other advanced technologies will play an increasingly critical role in supporting the conservation

and sustainability of our natural environment by providing immediate up-to-date and constant information on the status of the environment whether on land or in the sea. Working in partnership with the John Nurminen Foundation provides the opportunity to explore that role further. Nicole Robertson, Vice President, Environmental Social and Governance at Nokia, said: "Through our subsea optical fiber networks, innovations such as acoustic sensing technology, or remote environmental monitoring, Nokia can – and will – continue to play an important role in the marine environment. I am therefore delighted to announce Nokia's commitment to the Baltic Sea – a unique ecosystem on our doorstep. Working in partnership with the John Nurminen Foundation, is a great example of how

we can collaborate with partners to drive sustainable change and help protect critical natural resources and habitats." Annamari Arrakoski-Engardt, CEO of John Nurminen Foundation, said: "The John Nurminen Foundation works to save the Baltic Sea - one of the most polluted in the world. Successful results require the support from companies and partners. With Nokia as our main partner, we are able to implement tangible projects to combat eutrophication, the most severe problem of the Baltic Sea. An important part of our foundation's work is also spreading awareness about maritime culture and its link to the Baltic Sea identity. It is a valuable and appreciated joint effort to improve the well-being of our common sea, a work that relies more and more also on advanced digital technology".



Nokia Unit Claims Largest 5G Factory Install in Europe

Operator Iliad Group, Nokia and its subsidiary Alcatel Submarine Networks combined to create what they described as the largest industrial 5G network in Europe, covering a 50,000sq/m site in France. The network is installed in Alcatel Submarine Networks' systems production and assembly facility in Calais and had been more than two years in the making. In a statement on the inauguration of the

network, Alcatel Submarine Networks noted it would "eventually" cover 11 buildings and loading docks, and would use 59 5G small cell antennas. The deployment is part of attempts to up use of digital technology in its business. It hopes the network will enable greater management of resources, better working conditions for employees, boost implementation of an energy consumption monitoring system

and honed maintenance processes. Current and future uses of industrial IoT systems are targeted at ultimately improving the performance of the facility. The deployment is the latest use of 5G for private industrial networks, a frequently-cited business case for the technology deemed by several industry players as a major opportunity for operators.

Nokia and MCIT Boost Sustainability and Customer Network Support with New Maintenance Hub in Saudi Arabia

Nokia announced the opening of a new regional maintenance hub in Riyadh in the Kingdom of Saudi Arabia that will support its customers across the Middle East and Africa (MEA) region. The new center will provide repair and support services for Nokia's 5G and legacy telecoms network equipment as well as training to local engineers. The move supports Nokia's efforts to extend the lifespan of its network equipment through the adoption of circular practices that enable greater material efficiency and reduced waste, enabling more sustainable networks. The initiative is part of Nokia's plan to expand its operations in the Kingdom and support digital transformation and the localization of equipment services. Nokia's investment is dedicated to knowledge sharing particularly in undertaking complex and critical repair and reuse services while ensuring sustainable localization. The new center is expected to save at least four weeks of end-to-end logistics time as well as reduce the environmental impact of logistics by having a local center instead of a global model. Nokia will work in partnership with a local firm, Saak International on the initiative. The center is one of Nokia's first initiatives following the signing of a Memorandum of Understanding (MoU) between the Ministry of Communications and Information Technology (MCIT) of Saudi Arabia and Nokia in 2019. The agreement supports the country's 'Saudi Vision 2030' strategy. Nokia has set ambitious



targets to cut emissions across its value chain by 50 percent between 2019 and 2030 as part of its renewed science-based targets. Approximately 50 percent of global emissions come from the global production of materials and less than 10 percent of materials are treated as circular. Nokia adopted circular practices over 25 years ago and has made significant progress in adopting circular practices by reusing, recycling, and repairing legacy products and components to extend their life cycle and optimize waste management. In 2020, Nokia processed 5,870 metric tons of obsolete products and parts. Eng. Bassam Al Bassam, Deputy Minister for Telecom and Digital Infrastructure at MCIT, said: "We are pleased that Nokia has chosen Saudi Arabia as a regional hub for its maintenance operations to serve enterprises and service providers not only

in our Kingdom but also across the MEA region. This is yet another milestone in the collaboration with MCIT and it further deepens the strong relationship between Nokia and the Kingdom." Ibrahim Al-Abbas, Senior Country Officer for Saudi Arabia at Nokia, said: "Saudi Arabia has great significance to Nokia and is our largest market in the region. From this perspective, setting up a regional maintenance hub is an important initiative, and will enable us to offer our customers across the Middle East and Africa region world-class support services as well as improve the capabilities of local engineers. Extending the lifetime of products through the adoption of circular practices takes us a step closer to achieving our own climate goals while reducing waste and realizing the full value of our products."

Nokia and Telefonica Achieve 5G 2CC Uplink CA in a Commercial Network

Nokia and Telefonica Deutschland (O2) have announced that they have successfully aggregated sub-6GHz spectrum frequencies in a two-component carrier (2CC) uplink Carrier Aggregation (CA) trial in a 5G Standalone (5G SA) network. Nokia has previously demonstrated four component carrier downlink 5G CA, as well as uplink CA on millimeter wave spectrum. Together with Telefonica Deutschland, the Finnish vendor says it is the first to combine sub-6GHz spectrum to boost uplink throughput. CA will improve the

performance of 5G by delivering improved uplink network usability at the cell edge with higher reliability and lower latency. Nokia provided solutions from its AirScale portfolio and MediaTek provided its 5G mobile platform. The companies used the combination of a 20MHz carrier on the 1800MHz band and a 70MHz carrier on the 3.6GHz band using CA technology to achieve a peak throughput of 144Mbps. "We want to offer our customers an optimal 5G experience in their everyday digital lives. We are continuously working

on technological innovations that will make our O2 network of the future more powerful," said Mallik Rao, Chief Technology and Information Officer at Telefonica Deutschland, adding: "With frequency bundling, we will enable our customers to enjoy faster downloads and uploads in our 5G network in the future. Together with our long-time partner Nokia, we have succeeded in taking this step also for uploads in the 5G SA network. CA will take our 5G network to the next level and improve the network experience."

Nokia, A1 Telekom Austria Hit 2Gb/s in SA 5G Trial

Nokia and A1 Telekom Austria touted peak downlink data rates of 2Gb/s on the operator's standalone 5G (SA 5G) network by implementing three-channel aggregation (3CA) to reach higher throughputs and more coverage. The 3CA trial blended two mid-band carriers in the 3.5GHz TDD band and one capacity carrier in the 2100MHz FDD band for a total bandwidth of 160MHz. It used Nokia's AirScale 5G baseband, a 5G smartphone and a commercial 5G CPE on A1 Austria's 5G network. With 3CA, A1 was able to

increase the available bandwidth for mobile users by combining its spectrum assets. Nokia noted carrier aggregation could also be used to combine low-band spectrum with mid-band spectrum for increased coverage range of the high downlink data rates. Alexander Stock, CTO of A1 Austria, stated maximizing the operator's spectrum assets was an important milestone for enhancing coverage, capacity and performance. There has been a string of carrier aggregation trials in 2022 including BT announcing in

August it partnered with Nokia on a trial that combined four spectrum channels on mobile operator EE's live network. T-Mobile US announced earlier in December it had deployed a combination of three channels of mid-band 5G spectrum that reached peak data rates of more than 3Gb/s. GSMA reported in October that 27 operators have launched commercial 5G services on SA networks as of the first half of 2022, with an additional 15 expected to have launched or transitioned to SA networks by year-end.



Pacts Worth R0171 Million Signed to Boost Broadband Network in Oman

Oman Broadband has signed a series of long-term financing agreements with several banks in the sultanate worth R0171mn to be invested for expansion of its broadband network over a period of 15 years. These agreements promise more bank finances for extending the coverage of broadband network across all governorates in Oman. They are in line with the company's aim to refinance the loan of the Asian Infrastructure Investment Bank (AIIB), besides availing additional financing to support the expansion of fiber optic network across Oman. The move will help bridge the digital urban/rural divide, which is in line with Oman's National Broadband Strategy, said ONA. The long-term investment plan is a mix of traditional and Islamic financing by a number of local banks, including Bank Muscat, Ahli Bank, Sohar International Bank, Bank Dhofar, National Bank of Oman, Sohar Islamic Bank, Ahli Islamic Bank, and Maisarah Islamic Bank. "The signing of these agreements between the company and several local banks reflects the mutual trust, collaborative efforts, and long-term strategic partnership between both parties," said Said Abdullah al Mandhari, Head of the Board of Directors at Oman Broadband. "Through these agreements, we reaffirm our trust in Oman's economy, and we foresee



resilient growth in strengthening plans for digital transformation, and acceleration of its implementation throughout all governorates in Oman." Mandhari emphasized that the agreements reflect how confident the financial institutions are in terms of the company's operational and financial performance, especially after the company managed to complete the first phase of the development plan very effectively and in record time. Moreover, he pointed out that the agreements reflect the value that the company has achieved and delivered locally, by involving SMEs and Omani competences in implementing its

operational plans. "We extend our thanks to all members of the Oman Broadband family for their effective and outstanding performance in the first phase," Mandhari said, expressing confidence that the upcoming phase would highlight more achievements. "We also extend our thanks to the operational departments at each bank – for their continued efforts, flexibility, and professionalism in providing competitive interest rates to complete these agreements for the benefit of the public," he added.



Digicel PNG Bolsters Coverage with Additional O3b Capacity From SES

Digicel PNG, part of Digicel Pacific, is reportedly enhancing its coverage in Papua New Guinea (PNG) by leveraging SES's O3b medium-earth orbit (MEO) satellite system to provide its customers with seamless connectivity. In a press release regarding the development – which comes after damage to the international Pipe Pacific Cable (PPC) which resulted from a 7.7 magnitude earthquake in September 2022 – it was suggested that the additional O3b services will continue to help Digicel maintain connectivity during outages caused by such cable breaks while also expanding coverage across the remote

parts of the country. It was noted that during the disruption stemming from the cable damage, SES had assisted Digicel with emergency bandwidth, providing an increase of 40% in high-performance, low-latency O3b services deployed across twelve sites throughout PNG to keep communities connected. SES is also reported to have stepped in with an incremental 3Gbps of capacity and additional ground equipment to enable Digicel to restore its network connectivity and critical communications services for both consumers and telecommunication customers. 'We are grateful for SES's

swift response in provisioning additional capacity to enable us to plug urgent and unprecedented connectivity gaps,' said Digicel PNG CEO Colin Stone, adding: 'Our partnership with SES has been critical to not just disaster relief efforts in Papua New Guinea, but in connecting remote populations across the Pacific region ... We look forward to exploring the enhanced capabilities of SES's O3b mPOWER satellite system to fortify network connections thus minimizing network disruptions in the event of future disasters.'

SES Rockets to Next-Gen Birds with SpaceX Launch

SpaceX successfully launched two of SES' second-generation medium earth orbit satellites (MEO) that will increase the beams from 10 per bird to more than 5,000 in an effort to provide global connectivity across numerous verticals. The two Boeing-built O3b mPOWER MEO satellites blasted-off 16 December from Florida's Cape Canaveral Space Force Station atop a SpaceX Falcon 9 rocket. The satellites were in development for the past five years

after the first generation launched in 2013. SES CEO Steve Collar stated in a press briefing the birds would be commercially operational in Q3 2023 after achieving their 8,000 kilometers MEO orbits. The new satellites will enable roundtrip latency of less than 150 milliseconds to deliver global speeds from 10Mb/s to gigabits to government agencies, energy companies, cruise lines, enterprises, mobile operators, ships and planes. John-Paul Hemingway,

chief strategy and product officer for SES, told Mobile World Live that six of the birds could cover all of Earth, but the company plans to deploy a total of 11 in its satellite constellation. "We're building a big global telco wholesale edge," he stated. The satellites connect to SES' ground stations, some of which are located in Microsoft Azure data centers to enable low latency at the edge for mobile operators. SES also has a multi-cloud strategy in place with Amazon Web Services (AWS), Google Cloud and Oracle, but its primary partner is Azure. "We built a whole bunch of our gateways collocated with Azure data centers, so our customers are directly connected back to Azure the minute they use mPOWER," Collar stated. "They're coming back to one of our gateways and they have direct access to Azure services." Mobile operators will have access to a range of virtual network functions on Azure and AWS marketplaces when the satellites are live. The satellite provider will also use the mPOWER birds to connect to the network cloud at the edge to deliver compute and storage. Hemingway outlined several primary use cases for operators that will be empowered by the new satellite cluster including virtual 5G instances.





stc Bahrain Partners with Crayon and Microsoft to Empower Businesses with the Latest Technology Solutions

stc Bahrain, a world-class digital enabler, signed a strategic partner agreement with Microsoft and Crayon to offer Microsoft services portfolio to its business customers. As part of the partnership, stc Bahrain will be collaborating with Crayon, a Microsoft Cloud Solutions Provider, to provide the latest technology solutions to SMEs and corporates in Bahrain. The partnership is in line with Bahrain's digital transformation journey and its vision to position the Kingdom as a digital hub in the region. Moreover, it will solidify stc Bahrain's positioning as an innovator in the market by offering the latest advanced tech services to its business customers. The collaboration will also support stc Bahrain to address enterprise needs for digital transformation and modernizing their workspaces by offering cloud-based solutions. The products include the full

Microsoft portfolio like Microsoft 365, Microsoft Azure, Microsoft Dynamics 365, in addition to providing customers with Professional and Managed Services to deliver complete solutions. Eng. Nezar Banabeela, Chief Executive Officer at stc Bahrain, said: "We are delighted to partner with Microsoft & Crayon to deliver cutting-edge tech services and products for our business customers that support them on their digital transformation journey. The partnership signifies our commitment to provide the latest offerings for our business customers to keep them up-to-date with the latest tech solutions that will help them succeed and contribute to Bahrain's digital economy, in line with the Economic Vision 2030. The partnership will also enhance economic digitalization and improve the way businesses conduct their operations, and we are proud to be at

the forefront of enabling digital efficiency in the Kingdom." Commenting on the partnership, Ziad Rizk, Middle East and Africa CEO of Crayon, said: "At Crayon we believe in the power of technology driving the greater good. This is at the core of the partnership between STC Bahrain, Crayon and Microsoft. A partnership that sets a strong foundation for us to bring together the digital ecosystem in support of Bahrain's Economic Vision 2030 and further accelerates their digital transformation journey. We are committed to the success of this partnership and truly excited about the impact we can jointly drive in Bahrain" For his part, Charles Nahas, General Manager, Microsoft Middle East Cluster said: "Our collaboration with stc Bahrain speaks to our commitment to support businesses across Bahrain to support the digital transformation in the country. Together with our partner Crayon, we look forward to enabling stc Bahrain enterprise customers to leverage our trusted scalable innovative solutions to achieve more innovation, more resilience and more agility with less time and less cost." stc Bahrain is committed to developing innovative digital solutions for its customers as part of the Kingdom's digital transformation journey. This partnership with Crayon and Microsoft will enhance productivity and efficiency for businesses in Bahrain through the use of innovative tech solutions that will help them thrive and succeed as integral contributors to the economy.



stc Bahrain Highlights its Latest Cybersecurity Services at the Arab International Cybersecurity Summit

stc Bahrain is a key participant in the largest gathering of cybersecurity experts in the Kingdom, the Arab International Cybersecurity Summit, as Cyber Innovation Partner. The company is hosting a stand that highlights its latest cybersecurity solutions, in addition to interacting with key industry and business leaders in the Kingdom and the region. The stc Bahrain stand showcases the "stc Cybersecurity

Playbook", demonstrating the company's latest cybersecurity products and services. The stand features all the innovative services through stc Bahrain's partnership with Sirar, the cybersecurity arm of stc. Some of the available services that are showcased include data and application security, end point security, network security, web and email security, and more. The stand also featuring a live

performance show that invites visitors to be "hacked" to showcase the vulnerability of our digital assets and why all businesses need secure protection. The live hacking show demonstrates to visitors how hacking works and spread awareness on the importance for business leaders and employees to become more cyber aware and to protect their data.



Syniverse Releases Second Annual Environmental, Social, and Governance Report

Syniverse, “the world’s most connected company”, announced the publication of its second annual Environmental, Social, and Governance (“ESG”) Annual Report which details the Company’s ESG strategy and performance for the fiscal year ended November 30, 2021.

Syniverse engaged multiple stakeholders for its second annual materiality assessment, including gathering the opinions of employees, investors, customers, and suppliers to better identify the topics that matter most to each audience. Full detail on the assessment and placement of the most material issues can be found within the report. The Company’s ESG strategy and framework, which is titled “RISE,” is an acronym that identifies the four areas critical to long-term sustainability and success, including:

- **Responsibility** to promote ethical practices
- **Inclusive** culture for employees and global community
- **Service** integrity in performance, security, and privacy

• **Environmental** performance that protects the world

“In 2020, we laid the groundwork for understanding our impact better, creating transparent reporting processes, and setting targets to further our RISE progress into the future. In 2021, we took this work further and the material improvements achieved across our focus areas are reflected in our latest report,” remarked Andrew Davies, Chief Executive Officer, Syniverse. “In line with our 2020 commitment to enhance our

oversight of our suppliers, we have updated our Supplier Code of Conduct to promote responsible ESG actions across our supply chain,” said Kevin Beebe, Chairman of Syniverse’s Nominating and Corporate Governance Committee and Board member with responsibility for ESG topics. “We look forward to reporting further progress on these and other actions in our quest to create a more sustainable Syniverse for the future.”



Tech Mahindra Q2'23 Revenue Up 20.7% YoY

Tech Mahindra Ltd., a specialist in digital transformation, consulting and business re-engineering services announced the audited consolidated financial results for its quarter ended September 30, 2022.

Financial highlights for the quarter (USD)

- Revenue at USD 1,638 mn; up 0.3% QoQ and up 11.2% YoY
- Revenue growth 2.9% QoQ in constant currency terms
- EBITDA at USD 246 mn; up 2.9% QoQ, down 9.0% YoY
- EBITDA margin at 15.1%, up 30 bps
- Profit after tax (PAT) at USD 159 mn; up 11.2% QoQ and down 12.3% YoY
- Free cash flow at USD 253 mn, conversion to PAT at 159%.

Financial highlights for the quarter (₹)

- Revenue at ₹ 13,129 crores; up 3.3% QoQ and up 20.7% YoY
- EBITDA at ₹ 1,984 crores; up 5.5% QoQ, down 0.6% YoY
- Consolidated PAT at ₹ 1,285 crores; up 13.6% QoQ and down 4.0% YoY
- The Board has approved a special dividend of ₹ 18/- per share (360%) on the FV of ₹5.

Other Highlights

- Total headcount at 163,912 up 3.7% QoQ
- Cash and Cash Equivalent at USD 947 mn as of September 30, 2022

CP Gurnani, Managing Director & Chief Executive Officer, Tech Mahindra, said,

“We continue to focus on being resilient and agile to ensure long-term value for our people, customers, partners, and the soci-

ety at large. While market conditions evolve and supply-side challenges continue, we will strengthen our differentiated offerings to help customers in their transformation journey through our integrated & new-age solutions.”

Rohit Anand, Chief Financial Officer, Tech Mahindra, said,

“We have taken several targeted measures to achieve operational efficiencies and ensure long term sustainable growth. While we continue to address the dynamic market conditions, we will remain focused on creating value for our stakeholders, through continued operational rigor, robust cash generation and prudent capital allocation. Additionally, we have also announced a special dividend of INR 18 per share, in

line with our capital allocation policy.”

Key Wins

- Tech Mahindra has won a deal with one of world’s largest growing ERP solutions companies to provide digital product engineering, support & consulting services.
- Tech Mahindra was chosen as an exclusive strategic partner to provide consulting & managed services in Cloud Application Services by leading global enterprise software provider.
- Tech Mahindra has won a multi-year strategic deal with one of the world’s leading American software developer in the gaming industry, to help scale their content moderation business using our BPS capabilities.
- Tech Mahindra has been chosen by one of the largest omni-channel solutions provider based in Europe, for a multi-year deal to assist in the migration of its on-prem data centers to cloud, while delivering ITSM, Networks and Security transformation.
- Tech Mahindra was chosen by a leading American healthcare provider as a strategic partner in a comprehensive deal to assist digital migration of its existing platforms to a cloud-native, micro-services based architecture and offer a robust end-to-end digital healthcare to its customers.
- Tech Mahindra was chosen by one the largest defense conglomerates in Africa, as a strategic partner for digitally transforming its systems using SAP S/4 HANA. The multi-year deal will harmonise client’s business processes, digitalize its manufacturing entities using IIOT and implement centralized data governance & security.
- Tech Mahindra has won a deal with one of Africa’s largest telecommunications operators to manage digital workflows for their enterprise operations using Tech Mahindra’s ServiceNow Cloud Computing platform.
- Tech Mahindra was selected for a multi-year by a leading communications service provider in Europe to migrate its B2B legacy Monitoring solution to a new-age digital solution.
- Tech Mahindra was chosen by a leading communications service provider in Asia for managing the NOC & Operations, Service Desk for supporting Enterprise Customers of B2B Business.
- Tech Mahindra has won a strategic deal



with one of the largest players in wealth management & superannuation space for assisting in its Core System Transformation and multi-year RUN services on the new digital platform

Business Highlights

- Tech Mahindra partners with Google, to launch Google’s Street View in India. The partnership will leverage output from Tech Mahindra’s ‘Gullyfy’ project and Tech Mahindra will be responsible for GIS processes from data creation, resourcing, insights generation and the actual collection of the street-level imagery.
- Tech Mahindra partners with Union Bank of India to launch India’s first PSU Metaverse Lounge “Uni-Verse” to deliver a complete interactive and immersive experience across banking services. The lounge will help Union Bank of India to illustrate its digital savvy image to GenZ customers and encourage them to explore the bank’s products and services in the Metaverse ecosystem.
- Tech Mahindra partners with ColorTokens and SSIC to launch Strategic Cyber Insights, powered by X-Analytics, to deliver advanced Zero Trust cybersecurity solutions and risk management services. Through this first-of-its-kind service, Tech Mahindra will break new ground for enterprises in strengthening their cyber resiliency and help align their cyber security decisions with successful business outcomes.
- Tada Cognitive Solutions, a next-gen digital twin-enabled supply-chain software provider partners with Tech Mahindra to digitally transform supply chain networks for enterprises in the US. The partnership will enable Tech Mahindra’s customers to build real-time end-to-end visibility across the entire supply chain network with more than 4X faster control tower implementations. It is expected to further enhance collaboration among the various partners in the ecosystem to build modular decision systems.
- Quantre Solutions, a customer communications management consulting firm in the US partner partners with Tech Mahindra to provide next-Gen digitally enabled customer communication ser-

vices in US and UK. The combined efforts will focus on modernizing the customer communications industry across industries by employing cloud-native microservices including customer communication management (CCM), customer experience management (CXM), cloud-based ETL and data integration service and Functions-as-a-Service (FaaS).

- Tech Mahindra launches YANTR.AI, a transformational cognitive AI solution to enhance and simplify field services which will further strengthen Tech Mahindra’s BPaaS portfolio and provide end-to-end visibility, actionable insights, and recommendations to enterprises for better planning and execution of field services including address the demand & supply chain appropriately.
- Tech Mahindra launches end-to-end ESG portfolio to help businesses achieve their sustainability goals. Through these offerings, Tech Mahindra will enable businesses to configure, launch, analyze, manage sustainability targets, and help them achieve ESG goals through

tailor-made solutions for their distinct needs.

- Tech Mahindra announced a strategic partnership with XY Retail. The partnership will combine the power of Tech Mahindra’s deep domain expertise and system integration capabilities with XY Retail’s cloud-based unified omnichannel commerce solutions to enable customers to build a seamless and personalized integration of in-person and digital experiences.

Awards and Recognitions

- Tech Mahindra is recognized as a Constituent of the FTSE4Good Index Series June 2022.
- Tech Mahindra was recognized for the Best Wellness Programme in People Matters and MediBuddy’s wellness recognition initiative.
- Tech Mahindra wins Frost & Sullivan’s Technology Innovation Leadership Award 2022 for Metaverse Technology Services.
- Tech Mahindra recognized as the Brand of the Decade in the IT & IT Solutions

category by Herald Global in association with ERTC Media.

- Tech Mahindra recognized amongst the “Most Trusted Companies of 2022” by Var India. The listing aims to celebrate and appreciate technology brands that have played an important part in India’s Information Technology (IT) success story.
- Tech Mahindra recognized as Best of Asia – Most Admired Brand 2022 at the 10th White Page Leadership Conclave 2022.
- Tech Mahindra recognized for Best Employee Experience at ET Employee Excellence Awards in The Economic Times Employee Excellence Summit 2022 which aims to acknowledge and celebrate great employers and workplaces.
- Tech Mahindra was recognized among The Economic Times Best Tech Brands and among the Iconic brands for 2022.
- Tech Mahindra have been recognized as a Leader in Gartner’s Magic Quadrant for IT CSP for the 4th year in a row.



Tech Mahindra to Establish Its First Global Delivery Center in Egypt

Tech Mahindra, a leading provider of digital transformation, consulting, and business re-engineering services and solutions, has signed a Memorandum of Understanding (MoU) with the Information Technology Industry Development Agency (ITIDA) to establish a global delivery center in Cairo. Tech Mahindra aims to hire more than 1000 employees over the next three years to serve both global and local customers from its newly inaugurated center in Cairo. H.E. Mostafa Madbouly, Prime Minister of Egypt, Dr. Amr Talaat, Minister of Communications and Information Technology (ICT), Egypt, Shri Ajit Gupte, Indian Ambassador to Egypt, senior Egypt government officials, the top management team of Tech Mahindra,

led by its SVP & Head -Middle East & Africa, Mr. Ram Ramachandran attended the signing ceremony, which gathered multiple global tech key players. Dr. Amr Talaat, Minister of Communications and Information Technology sanctioned the agreement inked with Tech Mahindra, as part of several agreements with 29 multinational companies, creating over 34000 jobs directed towards exports through 35 global delivery centers with export value worth USD 1 billion annually. On the momentous occasion, Dr. Amr Talaat, Minister of Communications and Information Technology said, "With its unique central location at the crossroads between 3 continents, Egypt delivers a resilient high-quality digital infrastructure,

and provides a supportive legislative framework catching up with the global rapid growth. Our plentiful supply of tech talent is all set and ready at a competitive cost, with proven experience in business services delivery for global firms to more than 100 countries with 20 different languages." The new facility in Cairo assists Tech Mahindra’s clients across various sectors; namely, Telecom, Oil and Gas, BFSI (Banking, Financial Services, and Insurance), Energy & Utilities, and the Public Sector by leveraging Artificial Intelligence, Big Data & Analytics, Cloud and 5G technologies. This is in line with Tech Mahindra’s commitment to expand its global delivery centers and invest in the upskilling and reskilling of local Egyptian

talent. Harshvendra Soin, Global Chief People Officer and Head of Marketing, Tech Mahindra, said, "At Tech Mahindra, we are committed to diversifying our talent in delivery centers globally in the next few years. We want to widen the talent pool, improve agility to deliver solutions, and be closer to clients. We also have various up-skilling and re-skilling initiatives for our associates, enabling them to upgrade career opportunities and allowing us to retain the density of our talent pool." Amr Mahfouz, CEO of ITIDA, said, "We're thrilled to reach an agreement with Tech Mahindra, helping ITIDA achieve its strategic goals of the ambitious Digital Egypt strategy for the offshoring industry (2022-2026), that aims at multiplying the exports revenues from the offshoring sector, while creating more domestic jobs for our skilled pool of talent. ITIDA is working diligently to leverage the current geopolitical situation that led to major challenges across key delivery locations, while simultaneously monitoring the global shortage of talents. We invest heavily in building the digital and soft skills of our large talent pool, with a strategic focus on developing the country's capabilities in the high-value services, including engineering, research & development (ER&D), embedded software, and electronic design." Tech Mahindra is partnering with the Ministry of Communications and Information Technology (MCIT), to be an integral success partner of the Digital Transformation journey that the country is currently witnessing. Ram Ramachandran, Senior Vice President & Head of Middle East and Africa at Tech Mahindra, said, "Egypt is a source of great talent and technical skills that can boost our service



delivery in regional and global markets. It is also a key growth market for us in the MEA region; therefore, the launch of our technology center operations in Cairo marks an exciting milestone for Tech Mahindra. We aim to further strengthen our presence in Egypt with the addition of 1,000 employees within the next three years. We plan to support our Egyptian and global clients who want to operate in Egypt with

a wide range of services and technological capabilities." Tech Mahindra believes in DigitALL philosophy for comprehensive Business Transformation. As part of NXT.NOW™ framework, which aims to enhance 'Human Centric Experience', Tech Mahindra focuses on investing in emerging technologies and solutions that enable digital transformation and meet the evolving needs of the customer. 🌱

Every Experience Matters



Why simply satisfy your customers when you can thoroughly impress them? More meaningful relationships and lasting impressions drive experience excellence. Deliver this new standard to your employees and customers—everywhere in your business.

AVAYA

Experiences That Matter

ARTICLE

Avaya's Environmental, Social, And Governance Strategy – Creating Better Experiences Worldwide

Avaya believes that we have a responsibility to help create better experiences not only for our customers, but also for our employees and the global community. To that end, we have developed our environmental, social, and governance (ESG) strategy to align with the priorities of our employees and stakeholders.

How We Developed our ESG Strategy

We started by assessing environmental, social, and governance topics, taking into account recent political, economic, and cultural shifts that alter the way people live and work. After evaluating a range of topics, we created a survey that we distributed to employees, customers, distributors, suppliers, and partners, asking them to rank the importance of topics.

The 2030 Agenda for Sustainable Development, adopted by all United Nations Member States in 2015, provides a shared blueprint for peace and prosperity for people and the planet, now and into the future. At its heart are the 17 Sustainable Development Goals (SDGs), which are an urgent call for action by all countries – developed and developing – in a global partnership.

We found that governance issues were the highest priority to both our employees and our stakeholders, followed closely by several environmental and social issues. With this in mind, we developed an ESG strategy that focuses on doing the right thing for all our stakeholders. Learn more in our 2021 Corporate Responsibility Report.



Reeva Kymer
Director ESG & Philanthropy
Avaya



ESG Materiality Assessment

Our materiality assessment confirmed that the 14 ESG topics shown in this graphic are the most material to Avaya; these are the topics addressed in this report.

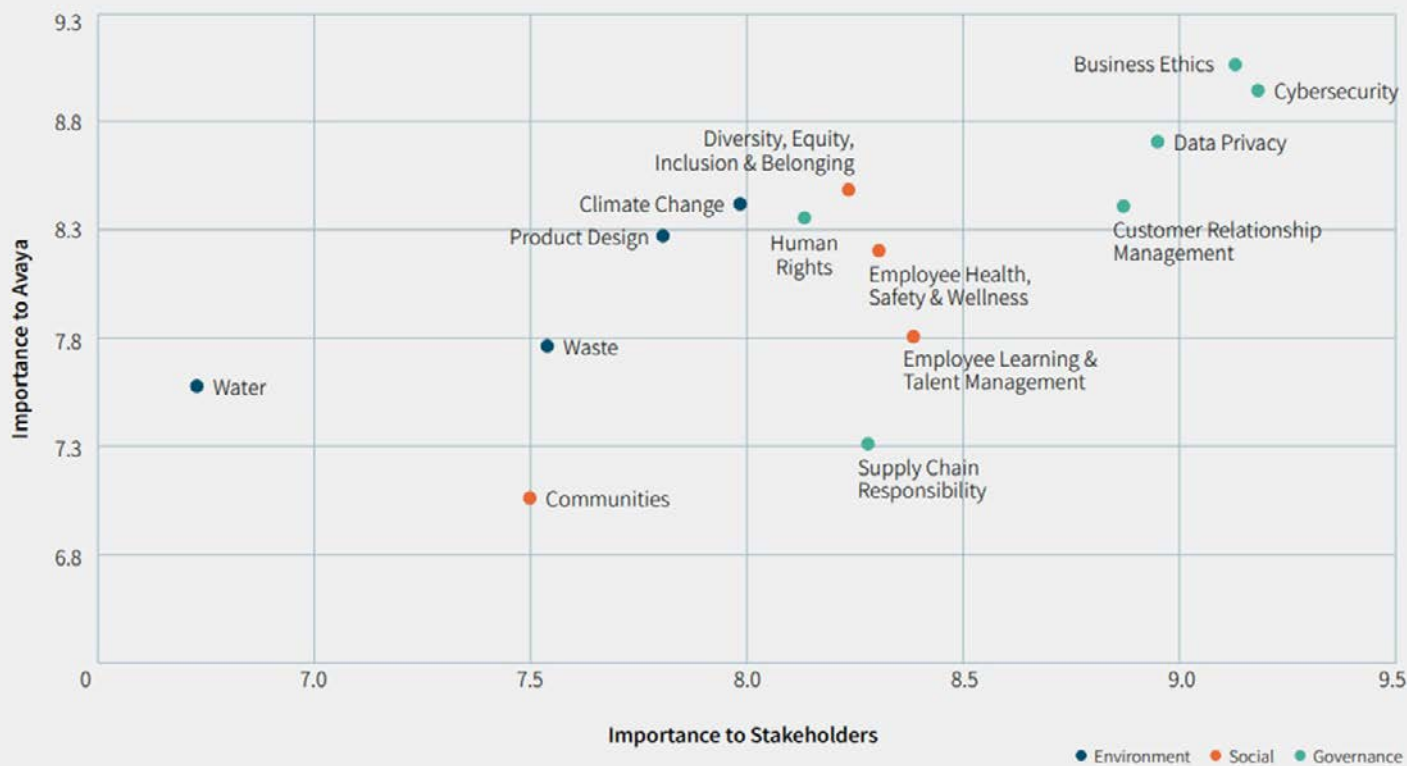

Source: Avaya 2021 Corporate Responsibility Report, page 9

Alignment with UN Sustainable Development Goals

The 2030 Agenda for Sustainable Development, adopted by all United Nations Member States in 2015, provides a shared blueprint for peace and prosperity for people and the planet, now and into the future. At its heart are the 17 Sustainable Development Goals (SDGs), which are an urgent call for action by all countries – developed and developing – in a global partnership. They recognize that ending

At Avaya, inclusion is a Cultural Principle, one of the guiding values we live by, and we are committed to providing a work environment in which every employee feels respected and included in decisions, opportunities, and challenges.

poverty and other deprivations must go hand-in-hand with strategies that improve health and education, reduce inequality, and spur economic growth – all while tackling climate change and working to preserve our oceans and forests.

The hope is that global attention to these goals will once again provide the investment and development needed to make the world a better place.

Our activities most closely align with six of these goals. Let's take a closer look:

Quality Education

SDG 4 aims to ensure inclusive and equitable quality education. Education liberates the intellect, unlocks the imagination, and opens a world of opportunities. The COVID-19 pandemic deepened a global learning crisis. In 2020, 46% of children in grades 1 through 8 were below minimum reading proficiency levels. In less developed countries, 33% of schools lack electricity and 40% lack handwashing facilities. Learning benefits every human

being and should be available to all. SDG 4 aims to achieve universal literacy and numeracy, free and equitable primary and secondary education, and an increased supply of qualified teachers.

Avaya contributes to this goal through our employee learning and development programs, and through our community partnerships. Through our India Corporate Social Responsibility (CSR) program and our partnership with Save the Children, we are enhancing the quality of education, utilizing technology to improve access to education, and supporting the construction of classrooms and associated infrastructure. Through these programs, we have enhanced education in India, Mozambique, Uganda, Afghanistan, and Vietnam.

Gender Equality

SDG 5 aims to end all forms of discrimination and violence against women and girls, and ensure women's full participation in leadership and decision-making.

In March 2022, Avaya committed to setting company-wide emissions reduction targets in line with climate science. We submitted our near-term targets for review by the Science Based Targets initiative (SBTi) and began the validation assessment process in September 2022.

At Avaya, inclusion is a Cultural Principle, one of the guiding values we live by, and we are committed to providing a work environment in which every employee feels respected and included in decisions, opportunities, and challenges. Our CEO is chairing our new Diversity, Equity, Inclusion, and Belonging (DEIB) Advisory Council, which is setting our strategy and providing guidance, advocacy, and support. Look for more on this in an upcoming blog.

Decent Work and Economic Growth

SDG 8 aims to support job creation; protect labor rights; end modern slavery, trafficking and child labor; and promote youth employment, education, and training.

Avaya strives to create a work environment where our workforce is agile and able to meet the needs of our customers and partners, while ensuring the employee experience is best in class. Avaya is committed to preventing the use of child labor, slavery, and human trafficking in our business operations and supply chain. The health and safety of our workforce is a top priority. We provide a safe and healthy work environment and respect the health and well-being of our workforce.

Industry, Innovation, and Infrastructure

SDG 9 aims to develop reliable, sustainable, and resilient infrastructure; promote inclusive and sustainable industrialization;

and significantly increase access to information and communications technology. One specific target of SDG 9 is to provide universal and affordable access to the internet, globally, bringing the information age to everyone.

Our business model supports increased access to information and communications technology. Avaya provides affordable, reliable collaboration and communications technologies to customers in over 190 countries, including to those in lower income regions to support their economic development.

Responsible Consumption and Production

SDG 12 aims to achieve sustainable use of natural resources. Our planet has provided us with an abundance of natural resources. But we have not utilized them responsibly and currently consume far beyond what our planet can sustain. One million plastic drinking bottles are purchased every minute, and five trillion single-use plastic bags are thrown away each year. Only 23% of electronic waste is recycled.

We must learn how to use and produce in sustainable ways. SDG 12 aims to achieve sustainable use of natural resources, halve food waste, and reduce waste generation.

Avaya complies with applicable regulations and partners with approved compliance

organizations to ensure our collection and recycling obligations are met.

Climate Action

SDG 13 aims to strengthen resilience and adaptive capacity to climate-related disasters, raise awareness on climate change mitigation and adaptation, and implement corporate and national commitments to reduce global greenhouse gas emissions. Climate change is a real and undeniable threat, and its effects are already visible. The global average temperature is 1.2 degrees Celsius above pre-industrial levels, and the world is not on track to stay at or below 1.5 degrees Celsius, as called for by the Paris Agreement, an international pact signed by almost every country on the planet. Through education, innovation, and adherence to our climate commitments, we can make the necessary changes to protect the planet.

In March 2022, Avaya committed to setting company-wide emissions reduction targets in line with climate science. We submitted our near-term targets for review by the Science Based Targets initiative (SBTi) and began the validation assessment process in September 2022.

More on our ESG strategy

In the near future, we'll share more about our ESG initiatives, including our efforts to drive our DEIB strategy. We take being a responsible corporate citizen very seriously and our activities are contributing to solving some of the world's most pressing challenges. For these and many more reasons, I am proud to be an Avayan! Please read the full 2021 Corporate Responsibility Report. 🌱

Together we evolve

The complete suite of high-quality iConnect products and services, ranging from global Voice, SMS, Data, Mobile to IoT and professional services, is built on one of the world's largest and most technologically sophisticated networks. iConnect is your connect-all carrier solutions that empower you to strive for even greater success in the journey of global connectivity.

To realize the potential of 5G, cloud, AI and IoT, CMI evolves with you to drive digital transformation and seize every opportunity.



180+ POPs SMS 70+ Cable Resources

CUSTOMER VOICE CARING IOT INNOVATION

iCONNECT

DATA Your Connect-All Carrier Solutions

PRO COLLABORATION MOBILE

INSIGHT INTEGRATION

100T International Transmission Bandwidth



Website



LinkedIn

cmiiconnect@cmi.chinamobile.com

REGIONAL NEWS

The Ministry of Communications and Information Technology Holds the International Forum on “Connecting the World from the Skies” in Riyadh

Under the patronage of H.E. the Minister of Communications and Information Technology Eng. Abdullah Alsawaha, the international “Connecting the World from the Skies” forum kicks off today in Riyadh with the participation of Their Excellencies as well as a group of CEOs from major NTN companies, prominent international experts and researchers in technology and investment, in addition to international regulators. Dr. Altamimi, the Governor of Communications, Space and Technology Commission, demonstrated in his opening keynote presentation that the goal of organizing the forum is to build bridges and promote cooperation to enable innovations that will contribute to the growth and diversity of the economy, as well as to the creation of a shared and fair space for all, which reflects the Kingdom’s mission and its global partners. This is achieved through international collaborations and partnerships between international organizations such as the ITU. He also assured that NTN is effective at increasing coverage and reaching the most inaccessible areas, to achieve sustainable use of future networks to serve the humanity meaning without adverse effects on the planet. Dr. Altamimi described the Kingdom’s innovation and technology market as being the largest and fastest growing in the MENA region; emphasizing the importance of continuity in enhancing

the Kingdom’s position in the ICT sector by adopting and investing in future technologies, as well as implementing trials to provide innovative solutions in the field, and driving development by authorizing regulations to encourage the sector to grow. Saudi Arabia became the world’s first country to conduct 5G testing using HAPS, and the first trial of 5G backhauling using LEO satellites in MENA region. The international “Connecting the World from the Skies” forum is part of the Commission’s non-terrestrial networks

program, which discusses several topics related to the most prominent services provided by non-terrestrial networks, as well as their organizational and technical aspects, through its specialized sessions, features the commission’s technical trials in the NTN field and demonstrates the NTN role in adopting the 6G telecom networks and how it provides a sustainable and eco-friendly solution. The forum also includes the Competition on Non-Terrestrial Networks for B5G and 6G, which was launched in collaboration with IEEE.



CONNECTING THE
WORLD FROM THE SKIES

CST

هيئة الاتصالات والفضاء والتقنية
Communications, Space &
Technology Commission

ITU

Saudi's MCIT Inks MoU with Huawei to Boost Digital Economy

The Saudi Ministry of Communications and Information Technology (MCIT) and Huawei signed a memorandum of understanding to enhance cooperation in the field of communications and information technology. The MoU was signed in Riyadh on the sidelines of the historic visit of President of China Xi Jinping to the Kingdom of Saudi Arabia, by

Eng. Bassam Al-Bassam, Deputy Minister for Telecom and Infrastructure Saudi Arabia, and Eric Yang, CEO of Huawei Saudi Arabia. The event was attended by Eng. Khalid AlFalih, Minister of Investment, Eng. Haytham Alohli, Vice Minister, Minister of Communications and Information Technology, Mr. Steven Yi, the President of Huawei Middle East and Central Asia

region, and several officials from both parties. Under the terms of the agreement, the Ministry and Huawei will collaborate to realize a '10Gbps Society', seeking to build a superfast broadband infrastructure to support the digital transformation goals of Saudi Vision 2030. These improvements will also enhance the competitiveness of Saudi ICT infrastructure globally. Towards

this end, Huawei will leverage its global expertise and success stories to support the MCIT in finalizing the business case and designing the required regulations to accelerate the 10Gbps society goal. An initial 10GB district pilot will be launched in 2023. Small businesses are the backbone of the Saudi economy, while its burgeoning startup ecosystem is inspiring unprecedented innovation and disruption across various domains. To support this evolution, Huawei will work with the Ministry to support digital entrepreneurs working on smart cities, IoT, AI, gaming, fintech, e-commerce, and blockchain projects. The two entities will also jointly promote the HUAWEI CLOUD startups program, a support program for empowering SMEs to develop their cloud capabilities. Additionally, the Ministry pledged to provide Huawei with support to build a cloud computing region in the Kingdom as cloud adoption accelerates in Saudi Arabia. Huawei will, on its part, work to strengthen partnerships with local data center service providers. Saudi Arabia recognizes ICT talent development as a key pillar of its Vision 2030. The MoU establishes a joint framework to launch a

Huawei scholarship training program to train university students, including visits to Huawei headquarters to experience the company's technology first-hand. This initiative extends existing Huawei skills development programs in Saudi Arabia, including the ICT Academy and Seeds for the Future. As Saudi Arabia accelerates the shift toward a digital government, the Ministry and Huawei will also collaborate

to build a nationwide Unified Government Network Infrastructure standard to serve all government entities. Steven Yi, the President of Huawei Middle East and Central Asia Region, who had witnessed the ceremony said, "This partnership aligns with Saudi Vision 2030 and the Ministry's continuous efforts to advance digital transformation, enhance ICT skills, and foster a culture of innovation."



PTA Hosts Consultative Workshop on Gender Inclusion Strategy



Pakistan Telecommunication Authority (PTA), in collaboration with UNESCO Pakistan, hosted the third consultative workshop for the development of digital gender inclusion strategy. The workshop was held in Quetta. The workshop, organized at PTA's Quetta Zonal Office was the third of a series of five consultative workshops being held to gather multi-stakeholder experts' recommendations for a strategy to reduce digital gender divide

in Pakistan. The workshop was conducted by Ms. Sadaf Khan, UNESCO consultant. Experts from various stakeholder groups including government organizations such as State Bank of Pakistan, PTV and others attended the workshop. Representatives from Global System for Mobile Communications Association (GSMA), NIC Quetta, telecom operators, academia, women entrepreneurs, tech start-ups and non-governmental organizations such as

Mercy Corp, People's Primary Health Care initiative (PPHI), and Health Education and Environment Program Balochistan (HEEP) etc. also participated. Director Wireless PTA and the head of PTA's initiative for gender inclusion in ICTs informed the participants that PTA is committed to ensuring the provision of best quality of services to all citizens of Pakistan including women. PTA's gender inclusion strategy is being developed with support from UNESCO Pakistan. It aims to recommend specific amendments and additions in policies that can help achieve gender parity in use of internet, mobile phones and digital skills in line with International Telecommunication Union's 2030 goals. This strategy will help PTA, along with other public and private sector stakeholders, to tackle various barriers to women's use of mobile and ICTs. The next workshop in the series is scheduled in Karachi on 22nd of December 2022. 📍

syniverse[®]

Unleash The Profitability of IoT With 5G

Syniverse accelerates the promise of the intelligently-connected world through the only complete end-to-end 5G roaming solution.



 www.syniverse.com

 +971.4.375.9644

ARTICLE

5G Roaming: Key Elements for a Successful Launch

Lennon Powder

Sr Technical Product Manager
Syniverse



The next generation of mobile platforms, 5G, is finally starting to get a foothold in the industry. A new Juniper Research study has found that the global number of roaming subscribers using 5G services will increase from 4.5 million in 2021 to 210 million in 2026.

This growth may be largely attributed to the benefits that 5G delivers such as expanded bandwidth and increased quality of services with lower latency and faster speeds. Another of 5G's most highly anticipated features is the ability to take advantage of network slicing. 5G technology is also finding its way into exciting new industry applications such as industrial IoT, healthcare, manufacturing, agriculture, and transportation.

Understanding what's necessary for an efficient and cost-effective roll-out of 5G roaming services will be critical for mobile operators looking to provide these new features to potential customers. These key elements, when part of a full-

Successfully implementing each of these elements can help operators quickly realize a return on their investment.

Moving from 4G to 5G

During the 4G to 5G transition, 5G networks will use 4G LTE technology as a steppingstone. The implementation of 4G/LTE has set the foundation for this next generation network. As a result, many operators will benefit from existing infrastructures that contain the critical elements necessary to allow them to benefit from 4G, while they implement the components to transition to 5G non-standalone, to 5G standalone.

The transition of 4G to 5G non-standalone and then to 5G standalone means that mobile operators will need to build off of their current infrastructure, such as IPX and Diameter Signaling. As mobile operators start migrating to 5G, there is a clear expectation that solution providers will ensure their existing portfolio also

Another of 5G's most highly anticipated features is the ability to take advantage of network slicing. 5G technology is also finding its way into exciting new industry applications such as industrial IoT, healthcare, manufacturing, agriculture, and transportation. Understanding what's necessary for an efficient and cost-effective roll-out of 5G roaming services will be critical for mobile operators looking to provide these new features to potential customers.

featured solution that incorporates all of the components necessary to deliver high quality roaming services, include signaling, security, policy, intelligence and clearing.

evolves in a timely manner to support the 5G migration. Having a Diameter Signaling Service for 4G/LTE Roaming that is enhanced to support 5G non-standalone

roaming will be critical in this transition. Additional services like Diameter mediation, testing, and troubleshooting will enable commercial launches of 5G non-standalone roaming now, while helping to set the stage for 5G standalone in the future.

The importance of 5G signaling

Along with the promises that 5G brings to the market, it is also predicted to open additional opportunities for a massive influx of “connected” mobile devices such as phones and tablets. These connected “things” are designed to improve efficiencies within prominent business verticals including manufacturing, healthcare, and utilities. This incursion will also drive the growth of signaling on a massive scale, thus impacting routing, mediation and interworking functions that addresses load balancing and crucial management capabilities.

5G introduces a new cloud-native and web-friendly protocol called HTTP2 to replace Diameter and GTPv2 protocols. Implementing a new HTTP2 based 5G Signaling Controller to enable roaming with a 5G Core, specifically for 5G standalone networks, will deliver the real 5G experiences and market opportunities beyond Enhanced Mobile Broadband.

The transition of 4G to 5G non-standalone and then to 5G standalone means that mobile operators will need to build off of their current infrastructure, such as IPX and Diameter Signaling. As mobile operators start migrating to 5G, there is a clear expectation that solution providers will ensure their existing portfolio also evolves in a timely manner to support the 5G migration.

Enhanced security with 5G SEPP

While 5G continues to transform and enhance mobile connectivity, it’s enormous potential and almost unlimited connectivity potential bring about many security challenges by creating an expanded attack plane. Since security capabilities are critical for 5G roaming success, it’s essential that current and solid performing security measures are quickly put in place.

5G presents a new entity called Security Edge Protection Proxy (SEPP) to ensure security for interconnection and roaming between networks. This may well be one of the most important functions on the network, given the huge emphasis on security in 5G. SEPP resides at the edge of the network and provides integrity protection, confidentiality protection, replay protection, spoofing protection and topology hiding. It is the application that aggregates all the roaming interfaces into a single interface, then packages it in a tight encryption layer, and sends it off to the partner operator. It is one of the key enablers for end-to-end security in 5G.

The need to apply policy with 5G roaming

With the predicted influx of more 5G-based devices, operators need to prepare their 5G networks to support this without compromising service quality. This can be achieved by offering both consumers and enterprise customers a diversity of

services. The expanded capabilities of 5G will support a wide variety of services with various characteristics and needs, requiring specific policies to be applied.

Investing in quality policy and charging control services that play a serious role in the 5G ecosystem will provide transparency and control over the consumption of network resources during real-time delivery.

Employing these policies will allow operators the flexibility to design 5G roaming services based on individual requirements of consumers or enterprises, which in turn will allow them to benefit from the expanded capabilities of 5G to enhance the user experience and drive increased revenues. A robust and customizable policy framework must therefore be able to adapt to these specific applications.

Investing in quality policy and charging control services that play a serious role in the 5G ecosystem will provide transparency and control over the consumption of network resources during real-time delivery. This will also allow

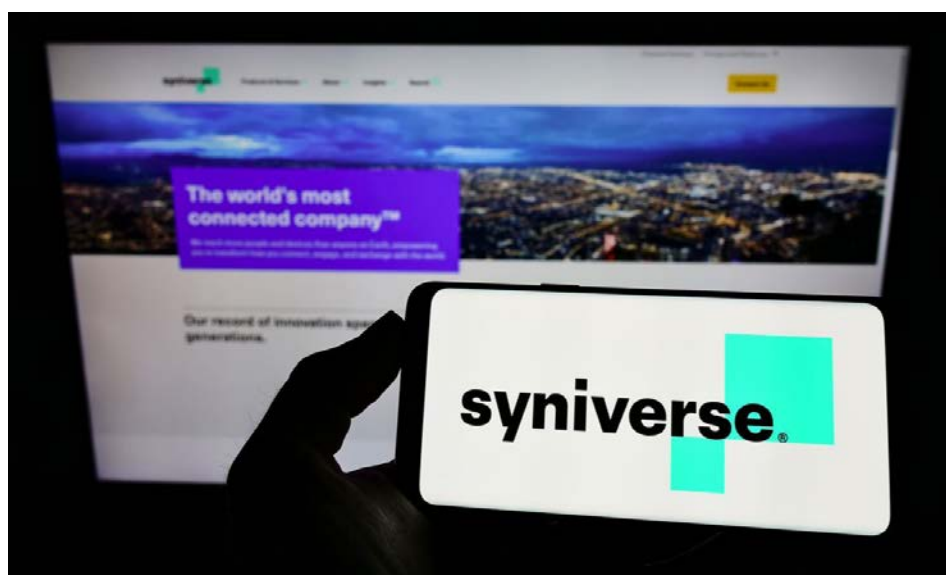

The promise of 5G to deliver high speeds, expanded bandwidth, and low latency means that virtually everything, everywhere, will be connected in some way. For IoT devices that are seemingly far and wide, 5G will make certain that they are truly ubiquitous.

operators the ability to better monetize the customization and differentiation of services with greater flexibility and less cost.

Analytics and gaining visibility into the 5G network

The promise of 5G to deliver high speeds, expanded bandwidth, and low latency means that virtually everything, everywhere, will be connected in some way. For IoT devices that are seemingly far and wide, 5G will make certain that they are truly ubiquitous.

Identifying different types of roaming traffic on a 5G network will be critical, especially for IoT traffic that can travel into a network relatively unnoticed, yet still consume signaling and data. With numerous IoT devices potentially roaming into and out of these networks, what seems like small inconsequential consumption can quickly add up to significant amounts. Having greater visibility into what devices are traveling into an operator's network, and how much signaling and data resources they are consuming, is critical to fully understanding what is utilizing the network and most importantly, how to charge for that usage.

Clearing and Settlement in 5G roaming

5G puts new requirements on the way that charging and billing is performed and interacts with the network. With the expected explosive growth of 5G supported IoT devices roaming across networks, operators will start to face the limitations of legacy charging and billing systems.

Ultimately, operators want to generate newfound revenues from 5G roaming. Monetizing roaming services through 5G will be different as billing moves away from foundational TAP services to the more modern Billing and Charging Evolution (BCE). BCE is better equipped to handle the

extended needs of 5G, helping operators justify the 5G business case while supporting new commercial parameters for charging and clearing, slicing, potential SLAs, and data exchange.

This is important as the types of devices being supported expands. Mobile IoT is one of the core business initiatives behind 5G and new commercial and charging models are required to support it. Legacy charging protocols like TAP are just not flexible enough to meet the needs of the wide variety of use cases to come.

For over 30 years, Syniverse has been a crucial part of the mobile industry. By developing and delivering products and services that address the current and emerging needs of customers, they can quickly go to market with high quality, revenue generating solutions that utilize minimal resources while executing full service, cloud-based results.

Moving to a new billing service also has its challenges though, as not every operator across the globe is currently able to support BCE. The ability to identify when a wireless device is accessing a 4G network assets versus 5G assets, and then knowing when it is more feasible to produce TAP versus BCE records, will be important.

Assuring Quality Through Testing

Testing of network platforms is extremely important in today's dynamic mobile

industry, in order to assure the highest quality of international roaming services can be provided to the roaming subscriber. The process of assuring the proper functioning of communication links and the ability of calls are part of both the IREG and TADIG standardized testing that is completed prior to finalization of the international roaming agreement between global operators. These tests play an important part in ensuring the quality and profitability of mobile services for both the home and visited network.

The optimal solution for operators rolling-out 5G roaming services is to tap into a provider that can offer resources to help supplement an operator's own employees in the support 4G and 5G roaming. This includes performing 5G testing with existing or new roaming partners, traditional mobile operator roaming, or expanding to roaming with private networks.

The Benefits of a Complete End-to-end 5G Solution

Complete and fully tested solutions can be highly advantageous when implementing new technologies. For over 30 years, Syniverse has been a crucial part of the mobile industry. By developing and delivering products and services that address the current and emerging needs of customers, they can quickly go to market with high quality, revenue generating solutions that utilize minimal resources while executing full service, cloud-based results. Syniverse is uniquely positioned to ensure existing mobile network operator product portfolios can efficiently and quickly evolve to support the 5G migration. Along with premium IPX Network connectivity, Syniverse's 5G Roaming solution includes enhanced Diameter Signaling Service for 4G/LTE Roaming to support 5G non-standalone roaming, which allows LTE-based operators to implement 5G roaming services now. As operators move to standalone, Syniverse is ready to support the expanded capabilities of 5G through a 5G Signaling controller supporting HTTP2, advanced security through 5G SEPP, a robust charging and clearing with Billing and Charging Evolution (BCE), policy controls, comprehensive analytics, and business intelligence. 📍

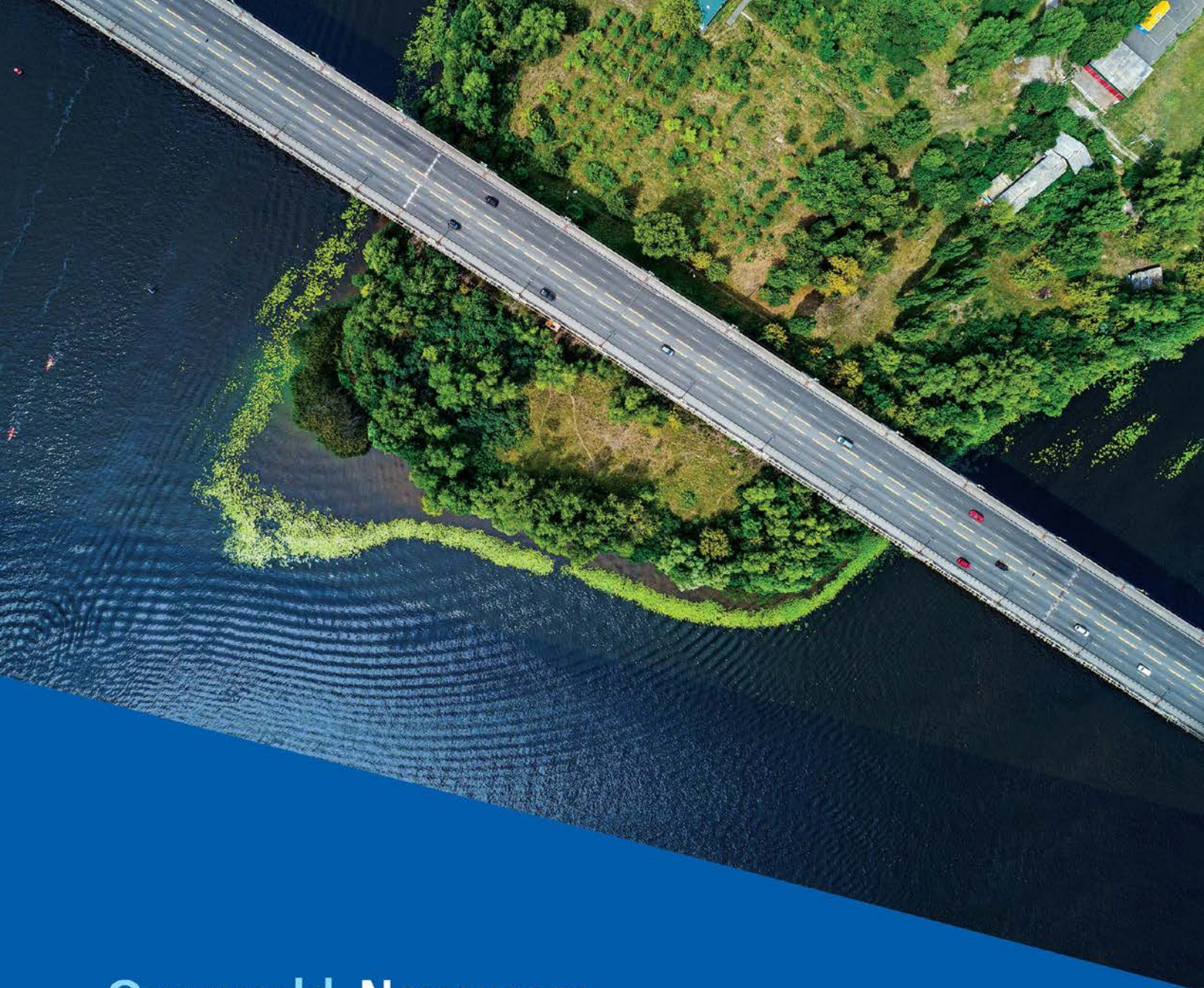

Our world. Now more
connected than ever.
Your world.

عالمنا. تواصل أكثر
من أي وقت مضى.
عالمكم.

عرب سات
ARABSAT



عالمنا... عالمكم.
Our world. Your world.

www.arabsat.com

SATELLITE NEWS

Satellite Services to Reach US\$141 Billion by 2030

The deployment of satellite constellations in Low Earth Orbit (LEO) for low-latency and high throughput network applications and extending terrestrial network (TN) coverage have become significant drivers in the adoption of satellite services in the global telecommunications sector. According to global technology intelligence firm ABI Research, this adoption would culminate in \$141 billion worth of annual service revenues from satellites by 2030. "Satellite communications services have seen a new wave of enthusiasm and convergence with terrestrial networks looking to extend past their zones of coverage and bridge the digital divide," said Andrew Cavalier, Satellite Communications industry analyst at ABI Research. Market developments

have shown that satellite services like Internet of Things (IoT), backhaul, commercial broadband and Mobile Satellite Services (MSS) could meet carrier-grade performance requirements and enhance the telecom arsenal of any terrestrial CSP. With over 70 satellite service providers currently providing services worldwide, some of the most influential players in the growing satellite communications services space include OneWeb, SpaceX, Hughes Network Systems and Globalstar. There is an increased focus on deployments in LEO for key satellite services in broadband, backhaul, IoT and MSS mobile applications. For the consumer segment, the competition over rural and remote market share would become a central battleground and one

of the key drivers impacting the growth of these services over the next decade. For the enterprise segment, global supply chains are evolving in the aftermath of Covid-19 and conflict in Europe and are keen to build more resilient and efficient networks. To reflect these developments, ABI Research anticipates that these essential satellite services, in aggregate, would reach over 53 million subscribers by 2030. "The market is evolving quickly, and many services are finding enhanced deployment through strategic alliances and increased bandwidth supply in LEO," comments Jake Saunders, vice president of Asia Pacific and research director for ABI Research's satellite communications service. Leaders are beginning to offer several solutions focusing on satellite-to-mobile device connectivity in partnership with telcos and smartphone manufacturers. Major partnerships include T-Mobile and SpaceX, Telstra and OneWeb, Vodafone and AST SpaceMobile, and Huawei and BeiDou. "While these services are still in their early stages, there is evidence that they would find momentum as smartphone technology begins to peak, sales taper off, and new revenue streams grow in demand. To this end, the market is revealing new development paths that would influence the market and shape partnerships and opportunities for enterprises throughout the telecommunications value chain," Saunders said.



SpaceX Seeks FCC Approval for Sat-to-Phone Birds

SpaceX is seeking to clear regulatory hurdles with the US Federal Communications Commission (FCC) for its satellite-to-phone service with T-Mobile US ahead of an expected launch in 2023. On 6 December SpaceX filed an application with the FCC to orbit more than 2,016 second-generation, low-earth birds for a direct-to-cellular system that would feature advanced phased array beam-forming and digital processing

technologies onboard. SpaceX CEO Elon Musk announced the service with T-Mobile US CEO Mike Sievert in August with a scheme that included a beta test in the latter half of 2023. The two executives touted the service's capability to reduce cellular dead zones across the US. The FCC filing stated the plan includes using the operator's nationwide mid-band PCS spectrum to provide voice, messaging and basic web

browsing with theoretical top speeds of 3 Mb/s or 7 Mb/s on the uplink and either 4.4 Mb/s or 18.3 Mb/s on the downlink. It also noted the service would work on unmodified off-the-shelf mobile phones, and that it would be available across the contiguous United States, Hawaii, Puerto Rico and areas of Alaska. There isn't a timeline for when SpaceX and the operator might be granted approvals by the FCC.

Microsoft and Viasat form Partnership to Deliver Internet to the Underserved Globally

Microsoft Corp. and Viasat announced a new partnership to help deliver internet access to 10 million people around the globe, including 5 million across Africa. Viasat, a global communications company, is the first satellite partner to work with Microsoft's Airband Initiative, and together they will deepen Airband's work in the Democratic Republic of the Congo, Nigeria, Guatemala, Mexico, and the United States, as well as prioritize expanding the program to Egypt, Senegal and Angola to deliver much-needed internet connection, often for the first time. This first of its kind global partnership for Airband is an important step in reaching the Initiative's expanded goal of delivering internet access to a quarter of a billion people across the world, including 100 million people on the continent of Africa, by the end of 2025. According to the International Telecommunication Union at the UN, roughly one third of the world's population - or 2.7 billion people - have still never used the internet. Satellite allows internet access to reach remote areas that previously have had few, if any, options for conventional connectivity. Working together, the companies will combine expertise and assets to help enable telehealth, distance learning and education, precision agriculture, clean power, and other services to reach new

areas through the transformational provision of power and connectivity. The companies will collaborate to provide and pilot technologies including, but not limited to, satellites (both geostationary orbit and low earth orbit) and fixed wireless. "We believe access to the internet is a fundamental right and that digital skills create and enable economic prosperity for people, businesses and governments. Through our Airband Initiative we will extend high-speed internet access to 100 million people on the continent of Africa and to a quarter of a billion people living in unserved and underserved areas across the world by 2025," said Teresa Hutson, Microsoft's vice president of Technology and Corporate Responsibility. "Working with Viasat, we will use satellite to reach remote areas that previously have had few, if any, options for conventional connectivity. Together, we will be able to rapidly scale and expand Airband's reach, exploring a wider pipeline of projects and new countries where we haven't yet worked." Nearly one third of the world's population is lacking online access to education, better medical care, business opportunities, connection with family and more. And most of this population lives in just 20 countries across Africa and the Global South. Universal, affordable internet

access is part of the United Nations' Sustainable Development Goals (SDGs), and by focusing a large portion of this new partnership on Africa, Microsoft and Viasat are working to deliver connectivity and digital literacy for better education, healthcare and economic opportunity in critical markets. "We're proud to partner with Microsoft as it represents another important step in bringing affordable internet service across Africa, Latin America and the U.S., as both companies continue to break down barriers to bridge the digital divide and make significant progress toward digital equity and inclusion," said Evan Dixon, President, Global Fixed Broadband of Viasat. "Providing internet access to the world is a challenging and bold goal, and doing so in a sustainable and responsible manner will unlock enduring opportunities for those who need it most." Through Airband, Microsoft and its partners have already delivered high-speed internet access to more than 51 million people globally, including over 4 million in unserved U.S. rural communities and an additional 47 million in 16 unserved and underserved countries outside the U.S. Launched in 2017, Microsoft's Airband Initiative works through partnerships with local and regional internet and energy access providers, telecom equipment makers and nonprofits, as well as governmental and nongovernmental organizations, to advance access to affordable internet and relevant digital skills around the world. Microsoft believes access to the internet is a fundamental right for everyone. Viasat is a global communications company and an innovator in satellite communications technologies and services, focused on making connectivity accessible, available and secure for all. Today, Viasat is connecting unserved and underserved communities around the world, many for the first time ever. This partnership builds upon the existing relationship between Viasat and Microsoft Azure Space to deliver advances in satellite connectivity and furthers Microsoft's mission to connect anyone, anywhere on the planet. 🌍

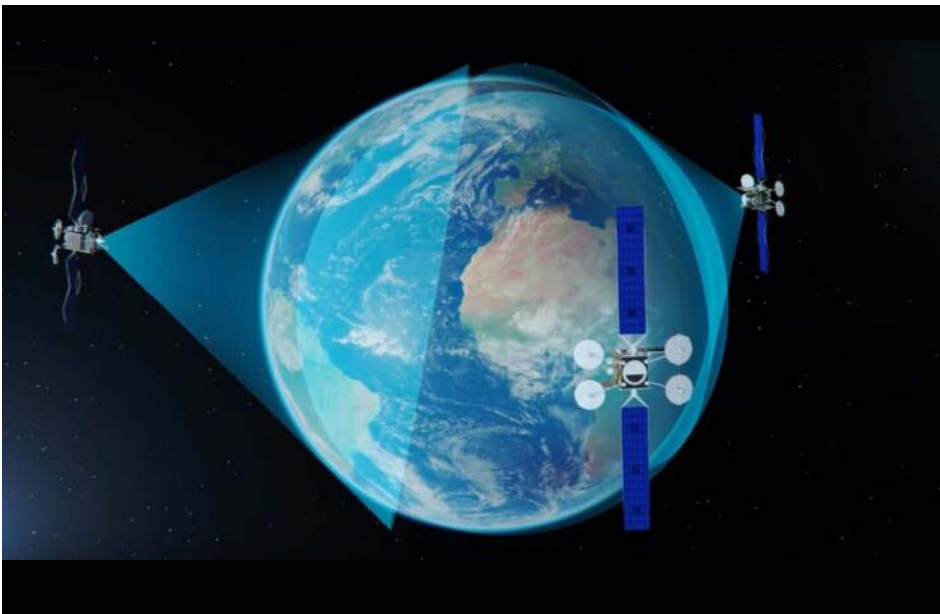

ARTICLE

Saudi Arabia: Success Factors and Advancements Towards Becoming the Leading Regional Technology Hub

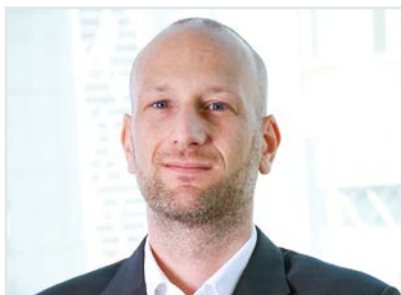

Rob van Dale
Partner and MEA Practice
Head - Digital Transformation

Kearney has been the advisor of choice for leading government entities in the GCC region, driving the strategic and digital agenda of nations, in close collaboration with their leadership. GCC's thriving and resilient technology sector offers tremendous insights for other countries of the SA-ME-NA region in adopting action-driven digital policies and investments.

Overall, driven by national ICT visions, the GCC countries are undergoing large-scale technological transformation. The Kingdom of Saudi Arabia is the GCC region's largest economy and is an engine propelling significant growth of the MENA Tech Market. As a result, the Information Technology (IT) and Emerging Technology (ET) markets across the GCC region is growing at a rapid pace.



Lukas de Sonnaville
Principal Technology & Digital

IT and ET is classified across six key segments – Hardware, Software, IT Services, Cloud and Data centers and Emerging Tech as Core while Digital Platforms as Narrow Current IT and ET sector market size for GCC countries

IT and ET is classified across six key segments – Hardware, Software, IT Services, Cloud and Data centers and Emerging Tech as Core while Digital Platforms as Narrow Current IT and ET sector market size for GCC countries stands at around 45 Bn USD and it forecasted to grow at ~10% CAGR (vs 7% Global CAGR), reaching 100 Bn USD by 2030.

stands at around 45 Bn USD and it forecasted to grow at ~10% CAGR (vs 7% Global CAGR), reaching 100 Bn USD by 2030. This rapid growth is attributed to emergence of data center and cloud businesses, increasing trend



Sanidhya Jain
Manager Digital Transformation

KEARNEY

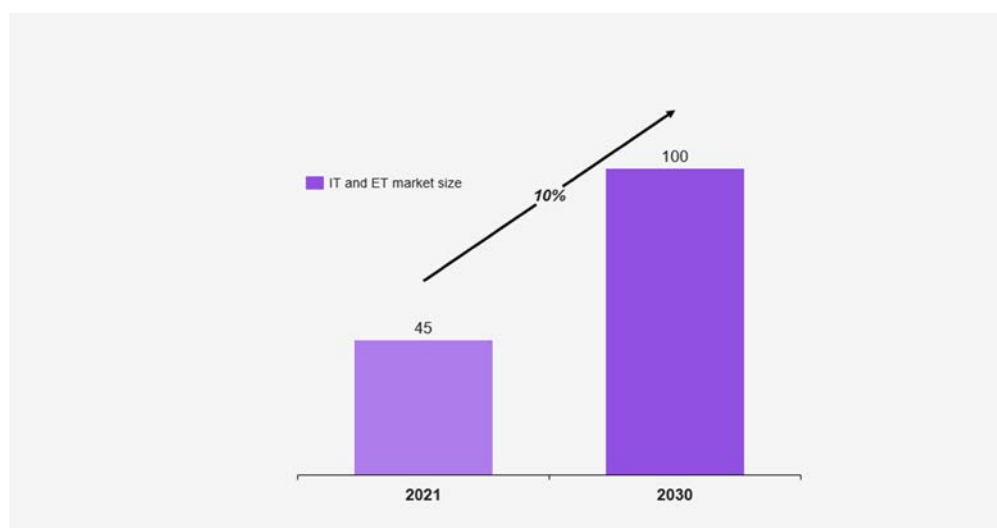

Figure 1: GCC IT and ET Market Size 2021 and 2030 Forecast, USD Bn

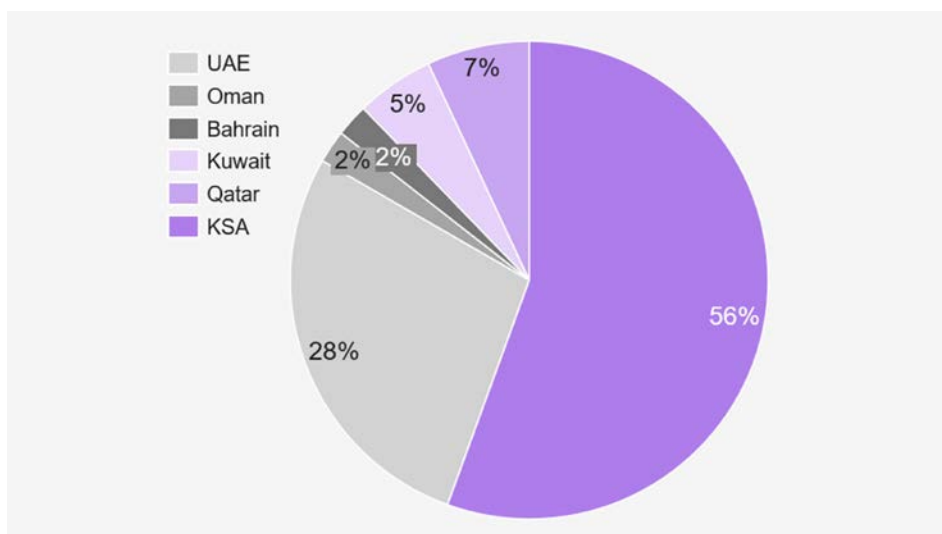

Figure 2: % share of IT and ET market by GCC countries, 2021

of platform business models and higher adoption of emerging technologies such as AI and IoT.

Saudi Arabia is one of the leading IT and ET market among GCC countries. In the case of Saudi Arabia, four main factors have significantly influenced and pragmatically driven digital transformation and growth in the market. These include: government focus on economic diversification, national push towards digital transformation, increasing adoption of emerging technologies and ease-of-doing business for the private sector.

- **Government focus to boost non-oil economy:** Vision 2030 has been defined with key focus on boosting non-oil economy. The aim is to reinforce and diversify the capabilities of the economy, turning KSA's key strengths into enabling tools for a fully diversified economy. Technology is one of the sectors which contributes majorly to growth of oil and non-oil sectors.

- **National push towards Digital Transformation:** Digital transformation has been accelerating across government and private sector in the Kingdom. This continued post Covid, fueled by "work-from-home" trend from citizens / residents and online service delivery and digital business models. KSA government successfully unlocked the opportunity by building applications such as Tawakkalna which clocked 15M+ downloads, and peaked post Covid. Apart from the user facing digital transformations, all the public sector entities are transforming internally as well, adopting digital solutions and moving away from paper-based operations with use of modern ERP and alike systems.
- **Increasing adoption of emerging technologies:** Several solutions in the Kingdom are increasingly applying sophisticated technologies such as Big data and AI. In addition, mega projects such as the Red Sea project and NEOM have spurred the demand for emerging

technologies such as Robotics, 3D printing, IoT and blockchain in the kingdom. As these projects are being developed, emerging technology will continue to grow in the Kingdom.

- **Thriving private sector and enhanced ease of doing business and regulations:** With recent jump of 30 places in Ease of Doing Business ranking, there are a high number of new businesses and companies registering and operating from within the Kingdom. It is estimated that 1,600+ companies operate in the IT and ET sector alone, with market growth sentiment being at all-time highs. Ministries and Regulatory entities such as the Ministry of Communications and Information Technology and Communication, Space and Technology Commission have been supporting the tech companies' growth in the private sector as well through dedicated initiatives and programs – ranging from grants, investment and funding support to capability development.

Success achieved in Saudi Arabia offer tremendous insights into how other countries within the SA-ME-NA region and policymakers can plan key strategic actions to realize the full potential of the IT and ET market, considering governments play a key role in enabling and supporting vital growth of various sectors now increasingly driven by digital technologies.

In the leading digital nations, including Saudi Arabia, Kearney observes nations have taken an active role across a range of programs and initiatives to support the technology sector. In doing so, they have materialized a thriving national technology market. We attribute such growth to two main set of internal and external elements:

1. Inward looking elements:

- **Specialized capability building:** Identifying key tech segments in a country and supporting national tech champions to excel in those segments. E.g., Malaysia's leadership in semiconductor manufacturing
- **G2B (Govt to Business programs):** Government can provide several areas of support to tech businesses, ranging from funding to talent development. E.g., Start-up India initiative provides seed funding,

Success achieved in Saudi Arabia offer tremendous insights into how other countries within the SA-ME-NA region and policymakers can plan key strategic actions to realize the full potential of the IT and ET market, considering governments play a key role in enabling and supporting vital growth of various sectors now increasingly driven by digital technologies.



Tech sector is the leading contributor to the # of unicorns (defined as privately held startup company with a value of over \$1 billion) in a country. Enabling start-ups through accelerators and VC funding access boosts the # of unicorns.

start-up awards and curated mentorship to tech companies

To continue the boom of the tech sector and to realize its growth potential in SA-ME-NA region, governments must continue their journey towards maturity following global best practices.

- **Market efficiency and transparency programs:** Government entities, especially regulators can launch dedicated initiatives to promote fair competition. In addition, also providing insights across the market segments such as market size, growth projections and so on. E.g., CST in KSA conducts

an annual comprehensive IT and ET sector market study to enhance market efficiency and transparency

- **Technology hubs and clusters:** Setting up dedicated hubs and clusters of technology benefits the tech companies by providing them end-to-end solution for the segment and ecosystem around their business. E.g., King Abdullah University of Science and Technology (KAUST) is developing a broader ecosystem for technology start-ups, SMEs and large enterprises. In addition, national initiatives are underway to position Saudi as one of the leading global tech hubs
- **Next Unicorns:** Tech sector is the leading contributor to the # of unicorns (defined as privately held startup company with a value of over \$1 billion) in a country. Enabling start-ups through accelerators and VC funding access boosts the # of unicorns. E.g., Indonesia added 7 new unicorns after pandemic to their existing tally of 3

2. Outward looking elements

- **Global growth and expansion:** With scalable technology sector offers, governments can push companies to expand their operations abroad – through opening up branch offices and / or setting up talent hubs in other countries.
- **FDI attraction:** Health of the technology sector is also determined by the investment it generates. Leading countries generate high volume of funds inflow in its technology sector
- **Technology exports:** Once the technology sector is mature in a country, it is a logical step to share those capabilities with other countries. Nations can develop a technology export strategy by matching highly mature domestic segments (supply) with attractive international markets (demand) for those services.

To continue the boom of the tech sector and to realize its growth potential in SA-ME-NA region, governments must continue their journey towards maturity following global best practices. Governments will also need to continue reforming and investing in their technology sector, through favorable policies, active stimulus in the market and enabling local players through Digital Transformations of Government entities. 🇸🇦

WHOLESALE NEWS

MTN, CamTel Implement First Phase of National Roaming

MTN Cameroon and state-owned CamTel (Blue) have announced the commercial launch of national roaming in Nkoteng, after a strategic agreement was signed between the two telecoms operators earlier this year. The move will allow CamTel to expand 2G, 3G and 4G coverage in areas of the country that are not already covered by its network. In the first phase, roaming has been enabled locally at more than 200 mobile sites, with this coverage set to be progressively expanded in the near future. 'We are extremely pleased with the launch of local roaming on MTN Cameroon's network. This service will allow CamTel customers to access network service in areas already covered by MTN where CamTel is not currently present,' stated CamTel's General Director Judith Yah Sunday Achidi, adding: 'At CamTel, we have the ambition to continue to grow our mobile telephony service and footprint and selected MTN Cameroon as a partner in this regard. We look forward to more of our customers enjoying voice and data services across various regions.'



4ka Still Discussing New Roaming Deal with Orange



Slovak mobile operator SWAN, which trades under the 4ka brand, is still negotiating a new roaming agreement with Orange even though the existing arrangement runs out at the end of this year. A report from Zive.sk says that 4ka customers are being guaranteed that they will not lose 2G and 3G connectivity via the Orange network even if the new deal is not signed by year-end. According to the report, the negotiations are being held up because 4ka now wants access to the Orange 4G network, while Orange had not expected this to take place until 2025. 4ka, which launched in 2015, has rolled out its own 4G infrastructure to around 85% of the country and currently uses the Orange 2G and 3G networks to connect calls in other areas.

Telefonica concludes sale of 45% of wholesale fiber unit Bluevia

Telefonica has announced the closing of the sale of 45% of Bluevia, the network operator that offers wholesale FTTH access and other fiber connectivity services in Spain, for a cash consideration of EUR1.02 billion (USD1.08 billion). Further, the latter – a joint venture of Telefonica Espana, Telefonica Infra and the consortium formed by Credit Agricole Assurances and Vauban Infrastructure Partners (through its managed fund Core Infrastructure Fund

IV) – has officially started operations after the completion of the transaction. A press release confirmed: 'Beginning with an initial footprint of 3.9 million premises, acquired from Telefonica Espana, Bluevia will expand its network to reach five million premises by the end of 2024, bringing ultra-fast fiber broadband access, a greener technology, to areas that currently do not have this service.'

Deutsche Glasfaser Concludes FTTH Wholesale Agreement with Vodafone

Deutsche Glasfaser has announced that it has concluded a wholesale cooperation agreement with Vodafone Germany for a period of at least ten years. Under the contract, Vodafone will be granted nationwide access to Deutsche Glasfaser's fiber-to-the-home (FTTH) network from autumn 2023, enabling it to reach up to six million additional households in the future. 'We are pleased that Vodafone is relying on our rapidly growing fiber-optic network in rural and suburban areas. Everyone benefits from open access: fiber-optic customers in rural areas have freedom of choice, and we as a company are getting closer to our goal of supplying the regions with fiber-optics quickly and comprehensively through such wholesale partnerships,' stated Deutsche Glasfaser's CEO Andreas Pfisterer, adding: 'We offer all telecommunications



providers the opportunity to use our infrastructure to expand their range of services. In this way, we promote fair competition between offers and services and advance the expansion of fiber-optics in Germany.'

BICS Completes Live 5G SA Roaming Connection Between Proximus and stc Kuwait

Wholesale carrier BICS, an affiliate of Belgian full-service provider Proximus, has successfully set up the first ever intercontinental 5G Standalone (SA) roaming connection between two live networks in Europe and the Middle East. The company claims the connection was the first of its kind to be performed in a non-laboratory environment and demonstrated successful roaming between the 5G SA networks of Proximus and stc Kuwait. Mikael Schachne, VP Telco Market at BICS, commented: 'Until now, operators around the world have only been delivering 5G Non-Standalone (NSA) roaming that routes traffic through 4G/LTE core. By establishing 5G SA roaming, we've broken down the barriers to bring the power of this technology to international communications. This is an important step for the industry, and accelerates the benefits of 5G to potential consumers and enterprises around the world.' Connectivity between the visited and home network was established via secured gateways (SEPP) – a next-level security

protocol mandated by roaming regulators GSMA, and which can be hosted on BICS' IPX network – for faster and more efficient implementation and management.

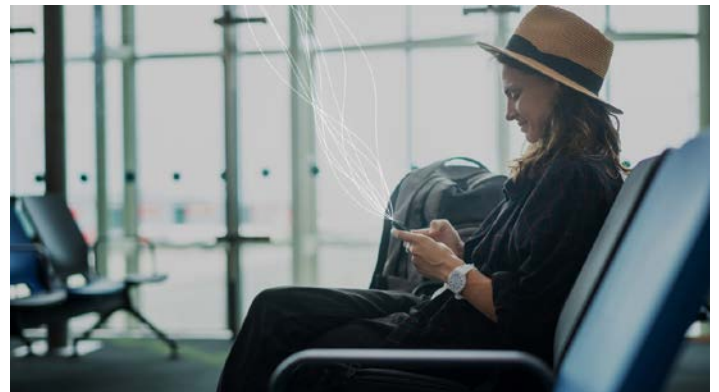

TRA, Bahrain Seeks Comments on BNET Wholesale Broadband Service Proposals

Bahrain's Telecommunications Regulatory Authority (TRA) has opened a public consultation on Wholesale Bitstream Service (WBS) tariffs proposed by BNET, the Kingdom's national fiber network provider. In a press release, the TRA stressed it expects retail providers to pass on the reduced wholesale prices to end users, while also welcoming BNET's proposal to increase broadband speeds in support of the Kingdom's digital development and global competitiveness.

Tele Columbus and 1&1 Agree Wholesale Cooperation

1&1 has announced that it has partnered with Tele Columbus (PYUR) for the marketing of fixed broadband connections in Germany. Under the new long-term wholesale framework agreement, the nationwide transport network of 1&1 Versatel will be connected to Tele Columbus' regional city network, enabling 1&1 to offer households high speed internet connections over an internet-enabled Tele Columbus cable or fiber connection from April 2023. Housing tenants with a Tele Columbus internet connection will soon be able to purchase 1&1 products and services, while for 1&1 the new cooperation agreement opens up additional marketing potential of more than two million households, with fixed products offering download speeds of up to 1Gbps. 'The network opening from April 2023 is widening the choice of broadband products and offers a genuine added value for our housing association partners and all of their tenants,' said Daniel Ritz, CEO and Chairman of the Management Board of Tele Columbus. Meanwhile, Ralph Dommermuth, CEO of 1&1, commented: 'Through the cooperation with Tele Columbus, we are able to further increase our coverage



with fast broadband connections. In addition to Tele Columbus' existing fiber and cable connections, we will also have access to fiber connections that will be built by Tele Columbus in the future. We look forward to working together to provide even more German households with fast and reliable internet connections.'

Malaysia 5G Wholesale Operator Finalizes Access Deals



Several major mobile operators in Malaysia worked out terms of access agreements with wholesale 5G network management outfit Digital Nasional Berhad (DNB) after months of negotiations, with all detailing plans to launch services soon. In stock market filings, Celcom Axiata, Digi, Telekom Malaysia and U Mobile detailed the signing of ten-year deals with DNB. The moves come three weeks

after all but U Mobile inked equity deals to take stakes in the state-owned special purpose vehicle. Digi stated the reference access offer is expected to be published after approval by the Malaysian Communications and Multimedia Commission. It tipped the move to a single 5G wholesale network to lead to a gradual shift from a traditional network ownership model towards a leasing approach. Digi added it will continue 5G network testing with its technology partners and DNB, and will soon offer compatible services Celcom Axiata detailed plans to automatically enable access to 5G services for customers on selected post-paid and prepaid plans from 1 November. It plans to waive access fees until 31 December. U Mobile's 5G service will be available on 3 November. YTL Communications was the first to launch 5G service in the country earlier this year.

MEAG, AVWL and Primevest Establish Wholesale Fiber Company

German asset manager MEAG, pension fund Arzteversorgung Westfalen-Lippe (AVWL) and investment firm Primevest Capital Partners (Primevest CP) have reached an agreement on creating a joint venture for the deployment of fiber-to-the-home (FTTH) networks in Germany. MEAG and AVWL will each hold 40% in Open German Fiber, with the remaining 20% owned by Primevest CP. The joint venture will operate as a wholesale company and, together with anchor ISPs, it is set to deploy local fiber-optic networks in underserved areas across Germany. For the initial regions, the trio jointly selected areas which will provide at least 150,000 homes with access to full fiber connectivity. The areas are located in



the regions of Hessen and North Rhine-Westphalia, where ISPs novanetz and YplaY will be responsible for marketing the fiber-optic network to customers. Construction work in the regions will commence this year. The transaction is subject to approval from the competent merger control authorities and closing is expected by the end of 2022.

Italian Wholesaler Confident on 5G FWA Push

Cosimo Buccella, CTO of Italian wholesale provider OpNet lauded the potential of 5G fixed wireless access (FWA) in Italy due to patchy progress in fiber rollouts, as he detailed plans to target operators with its infrastructure. Speaking to MobileWorldLive

after his presentation, Buccella explained OpNet aimed to provide FWA infrastructure to domestic mobile operators, alongside other connectivity services targeted at the industrial and the business sectors. "There is a big push on fiber but Italy is a complex

scenario," he said, explaining this meant operators "need to cover some specific areas also with FWA". He indicated with operators preoccupied with using their spectrum assets to serve increasing mobile consumption, the hope was OpNet could aid them with an FWA offering using 5G. In its previous guise of Linkem, the company provided fixed over WiMax as part of a broader portfolio. Although often cited as a technology suited to connecting rural areas without fiber access, the executive extolled virtues of fixed over its standalone 5G infrastructure in urban areas too, with strong performances recorded in Rome and other cities. He noted the technology was a strong compliment to fiber, adding it could "provide connectivity in five days" something "not possible with a fixed line". Italian operators with access to C-Band spectrum are looking at FWA as a new use case, he added. OpNet's active targeting of FWA in Italy comes as protracted attempts to create a single fiber network in the nation continue, which supporters believe will speed the provision of fast broadband across the nation.

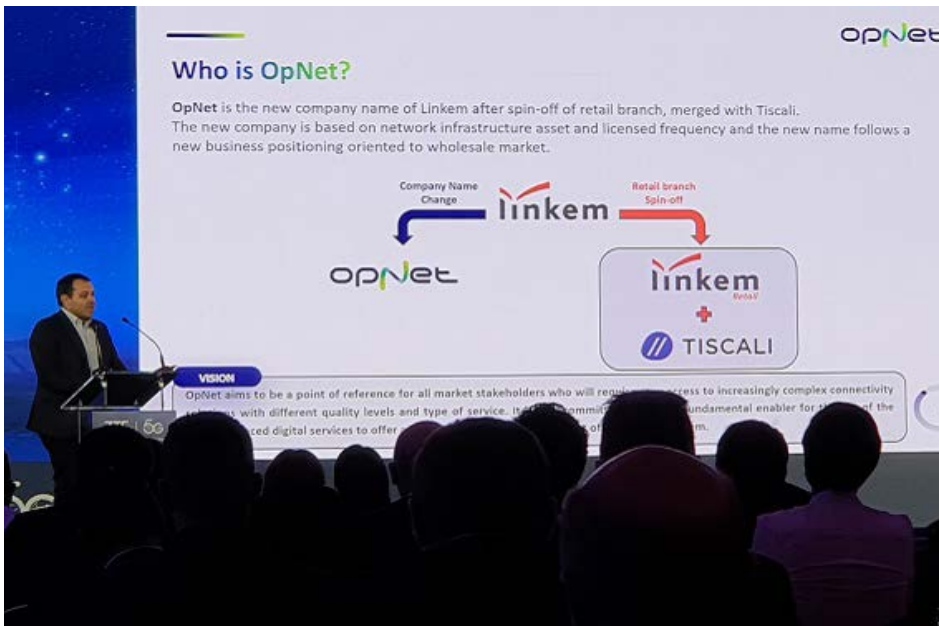

NCA, Operators Sign Landmark Interconnection Agreement

The National Communications Authority (NCA) and Somali mobile operators have signed an interconnection agreement to allow end users to call each other seamlessly across different telecoms networks. The agreement was a result of a series of discussions and consultations between the relevant parties that worked out all the fundamental issues necessary for the signing of the deal, including mobile termination rates (MTRs). The interconnection agreement will come into force on 10 January 2023, and the interconnection process will be completed by February 2023. 'In addition to the interconnection agreement being a requirement and a right for the customer, it is also an important benchmark for the growth of the telecommunications market



and the investment in technology and innovation, and I hope that this agreement will put an end to discussions that have lasted since the inception of telecom

companies in the country,' said the NCA's General Manager, Mustafa Yasin Sheik.

Malaysia 5G Wholesale Operator Denies State Funding

Digital Nasional Berhad (DNB), an entity set up by Malaysia's government to run a single wholesale 5G network, went on the defensive a day after reports of political scrutiny, insisting there is no state funding or guarantees anticipated or expected other than an initial start-up investment of MYR500 million (\$110.9 million). In a statement, DNB reiterated it will cost MYR16.5 billion to deploy the nationwide infrastructure over a ten-year period, which will be completely funded by revenue generated from the sale of capacity to mobile operators. It responded a day after Reuters reported the nation's new Prime Minister will review the controversial policy to create a single wholesale 5G network due to a lack of transparency in the formulation of the plan. DNB noted major operators Celcom Axiata, Digi, Telekom Malaysia, U Mobile and YTL Communications had agreed terms to access the wholesale network and have launched retail 5G services. Maxis continues to review the terms of the access agreement. The state-



run company said the 5G network currently reaches about 38 per cent of populated areas nationwide and is on target to hit a previously-agreed 80 per cent by 2024. DNB and equipment supplier Ericsson

stated they clocked a throughput of 1Gb/s on the 5G network using the 28GHz band at a distance of what they claim is a record of 11.18km from a radio antenna. 📶

Smart Office Solution

Intelligent collaboration and convenient wireless office experience.



Smart Office Solution

Smart & Simple, Everything as a Service



A NEW ERA OF
DIGITAL WORKPLACE
WITH IdeaHub



NEW NETWORK
ARCHITECTURE



ABUNDANT AND
INNOVATIVE TERMINAL
DEVICES

Contact Us

 enterpriseME@huawei.com

 e.huawei.com/ae

IdeaHub | Network | Super Devices

Stocks Available. Get Fast Delivery!

Learn More



TECHNOLOGY NEWS

ETSI Launches a New Group on Terahertz, a Candidate Technology For 6G

On 8 December the newly launched ETSI Industry Specification Group on Terahertz (ISG THz) held its kick-off meeting and decided on work priorities for this candidate technology for 6G. "ISG THz provides an opportunity for ETSI members to coordinate their pre-standards research efforts on THz technology across various European collaborative projects, extended with relevant global initiatives, a move towards paving the way for future standardization of the technology," outlines Thomas Kürner, Chair of ISG THz. The ETSI group will initially focus on two categories of use cases. The first one will include mobile applications with high data rate requirements, such as virtual and augmented reality, applications for in-flight and in-train entertainment, and vehicular and satellite communications. The second category includes applications requiring both communication and sensing functionalities, such as holographic telepresence, and interactive and cooperative robotics. The ETSI

ISG THz, which already comprises 31 participating companies, aims to define the target scenarios and the concrete frequency bands of interest on THz communications. Of major interest to the members of ISG THz will be the analysis of specific radio propagation aspects for THz communications, such as molecular absorption; effect of micro-mobility; specific considerations for scattering, reflections, and diffractions; and considerations for near-field propagation. As a starting point the group will analyze data from the numerous research efforts providing early measurement campaigns that has been published in relevant literature. To complement this work and fill the gap of missing data, it is expected that the members of ISG THz will perform channel measurements for the selected scenarios and frequency bands. This will enable the group to develop channel models for the selected scenarios and frequency bands and finally establish a

baseline for THz technology fundamentals, including antenna assumptions, simulation assumptions, and deployment strategies. Several European and international initiatives promoting 6G research and development activities anticipate that THz communications will be included in the next generation of cellular networks. The ETSI group will therefore support the future 3GPP standardization work. To a certain extent, THz communication has similarities and shared challenges with millimeter wave technology. Due to the need line-of-sight or at least obstructed line-of-sight to make use of one reflection or scattering process, Reconfigurable Intelligent Surfaces (RIS) are seen as an enabler for THz communications. This will provide ample opportunities for collaboration and joint undertakings with two other groups in ETSI, one working on millimeter wave (ISG mWT) and the other on Reconfigurable Intelligent Surfaces (ISG RIS).



Altice France Showcases Network Slicing on 5G SA Network

Altice France (SFR) has successfully implemented what it describes as the first use case of network slicing on its 5G Standalone (SA) network in France. The

trial was completed in real conditions at Altice Campus in Paris. Altice said that the 5G SA relies on a fully 5G core network, with capability to allocate resources over

several sub-networks called slices. Altice France claims to currently cover more than 6,600 municipalities (nearly 60% of the French population) with 5G.

Telstra Makes First 5G Data Call on Commercial Network

Australian mobile network operator (MNO) Telstra and vendor partner Ericsson have announced the first Ericsson Cloud RAN 5G data call on the former's commercial network. In a press release the two companies claimed that the 'landmark technology trial', which is taking place on the Gold Coast in Queensland, represented the first time that Ericsson's Cloud RAN virtualization technology has been trialed in a commercial network in the southern hemisphere. Ericsson's Cloud RAN solution virtualizes the RAN baseband as cloud-native network functions for the CU (centralized unit) and DU (distributed unit), while it has been suggested that virtualization of the RAN baseband will provide the MNO with increased flexibility, faster delivery of services, and more efficient network operations. Commenting on the matter, Iskra Nikolova, Telstra's Network and Infrastructure Executive, said: 'Telstra's ongoing partnership with Ericsson has reached another new milestone this week with the first 5G Cloud RAN data call over our commercial network utilizing Ericsson's industry-leading Cloud RAN technology. This achievement clears the way for the wider deployment of Ericsson's Cloud RAN technology, which will enable the full benefits of 5G for Telstra's customers across Australia.' In separate but related news, Telstra and Finnish vendor Nokia



have announced the deployment of Nokia Orchestration Center to build a reusable platform 'as a service' enabling Telstra's internal network domains faster time to market and an enhanced customer experience. In what the pair claimed was a 'global first', it was suggested that the rollout will allow Telstra to fulfil services in a more streamlined way by taking advantage of Nokia's Unified Inventory solution, while also providing discovery, reconciliation and ongoing synchronization of network and service assets in near real-time.

Speaking about the development, Lakshmi Easuwaran, Group Owner Orchestration, Enablement and Shared Technologies at Telstra, said: 'Nokia Orchestration Center has helped us to build a true cloud-native, reusable and shared Platform-as-a-Service (PaaS) offering (also known as Domain Enabler as a Service) for our internal network domains. Our customers not only benefit from an improved experience, but it will help us unlock new business opportunities by being able to introduce new products quickly and seamlessly.'

Globe, Nokia Report Successful 600G C Band + 400G L Band WDM Trial

Finnish equipment manufacturer Nokia has announced the completion of a trial of its C+L band WDM optical line

system with Philippines-based fixed and mobile operator Globe Telecom. The trial reportedly demonstrated the successful

operation of the vendor's PSE-Vs chipset, transmitting a 600Gbps channel in the C-band and a 400Gbps channel in the L-band on Globe's live fiber-optic network. Nokia said the trial paves the way for Globe's future growth to meet the needs of low-latency and high-capacity traffic demands for 100G and 400G services. In the press release, it noted that its C+L band solution doubles the capacity of the telco's national backbone network using Nokia's 1830 Photonic Service Switch platform. The trial was carried out using one of Globe's backbone networks between the Tarlac and Cabanatuan segment, located in the Northern Luzon part of the Philippines.



European Commission Allows Mobile Network Setup Inside Aircraft

Passengers traveling inside the European Union will be able to use their mobile phones to the maximum of their capacity and features, just like with a ground-based 5G mobile network. After a decision by the European Commission, airlines will be able to provide the latest 5G technology on their planes, alongside previous mobile technology generations. Thierry Breton, Commissioner for the Internal market, said "5G will enable innovative services for people and growth opportunities for European companies. The sky is no longer a limit when it comes to possibilities offered by super-fast, high-capacity connectivity." Since 2008, the Commission's implementing decision has reserved certain frequencies for mobile communications on planes, allowing airlines to provide messaging, phone calls and data services to passengers flying in the EU. This update of the Commission implementing decision on mobile communications on-board aircraft paves the way for the wide-spread deployment of 5G services. The service is provided within the cabin of an equipped aircraft using special network equipment, the so-called 'pico-cell', to connect the



users and route calls, texts, and data, typically via a satellite network, between the airplane and the ground-based mobile network. The Commission also amended an implementing decision on 5GHz frequency bands, which makes the bands available for Wi-Fi in road transport, for example in cars and buses. The amending decision lays the foundation for innovations in the automotive industry and potentially for

Metaverse applications. According to the amendment of the implementing decision, the Member States shall make the 5GHz frequency bands available for use aboard road vehicles as early as possible and at the latest by 30 June 2023. The question remains whether airlines are eager to bring this technology on board. And that passengers are willing to pay the (high?) cost price for data.

Balitower Taps Nokia to modernize Its IP Network And Enable 5G Services

Nokia Indonesia has revealed that telecoms tower and network infrastructure provider Bali Towerindo Sentra (Balitower) will use Nokia's mobile transport solutions and services to modernize its IP network

as part of a three-year nationwide project. It is understood the initiative will allow the infrastructure provider to increase network capacity and reliability and to deliver expanded 5G services for its customer

base. In short, Nokia will supply Balitower with routers providing a nationwide network, including the 7210 Service Access System (SAS) and 7250 Interconnect Router (IXR) with integrated Global Navigation Satellite System (GNSS) receivers enabling highly accurate synchronization. In addition, the Finnish vendor will supply Balitower with its Network Services Platform (NSP), as well as consultancy and services for network design and deployment. 'We are committed to providing experience to our customers and this project is a crucial step in this direction. We are already using Nokia solutions, and we are confident that Nokia's solutions and proven expertise will help us improve network capacity as well as prepare the network for 5G use cases,' Jap Owen Ronadhi, president director of Balitower is cited as saying.



Telekom Tests 5G in 6GHz Band

German telecoms operator Telekom Deutschland has tested 5G using frequencies in the 6GHz band in Bonn under real conditions. 'In order to meet our customers' increasing demand for more bandwidth with 5G, we will need more frequencies in the future. The tests have shown that the 6GHz frequencies are very well suited for this,' said Walter Goldenits, Head of Technology at Telekom Germany. For the test, a mobile communications site on the roof of Telekom's headquarters in

Bonn was equipped with a 6GHz antenna, and a special computer was configured as the end device. The tests achieved speeds of more than 1Gbps and if the frequencies are combined with the 3.5GHz band, then a transmission rate of more than 2Gbps is possible. Telekom notes that the future use of mobile radio frequencies depends on the regulatory framework set at the World Radio Conference in November 2023; if this is approved, then the frequencies could then be used in 2025 at the earliest.



Portugal Sees 5G Expand with the First Commercial Use of Huawei Hertz Platform Antennas



FDD 8T8R antennas based on Huawei Hertz platform have reached a new milestone with their first-ever commercial adoption in Portugal. The Hertz platform uses innovative technologies such as ultra-precision arrays (UPA) to support precise beam-

forming, as well as signal direct injection feeding (SDIF). It is the first of its kind in the industry to natively support FDD 8T8R antennas and can greatly improve antenna energy efficiency and help operators build an excellent 5G network that are also quite energy-efficient. Results show that Hertz platform-based FDD 8T8R antennas deliver 4.9 dB higher downlink coverage than FDD 4T4R. In addition, the uplink and downlink throughput are improved by 80% and 30% and the uplink and downlink cell-edge rates 40% and 60%. This shows that the spectral efficiency of FDD mid-band spectrum and user experience can be greatly improved. Since the commercial rollout of 5G, Portugal has witnessed a fast growth in 5G user base, which in turn requires continuous 5G coverage and better user experience. FDD

mid-band 8T8R, ensuring both coverage and user experience, is the next-generation key technology for 5G mid-band evolution. It has been used in more than 80 countries around the world for 5G basic network construction. Hertz platform antennas support FDD 8T8R and multi-band integration of more than 12 ports, and this makes it easier for operators to provide continuous cross-generation experience while ensuring fast deployment. Eric Zhao, President of Huawei Antenna Business Unit, emphasized, "Huawei antennas are committed to providing ultimate 5G solutions for operators to simplify deployment and maximize energy and spectral efficiencies. Hertz platform antennas, as the industry's first antennas to support FDD 8T8R, will assuredly boost 5G network development."

Samsung Claims FWA Records on mmWave

Samsung Electronics claimed to have demonstrated the ability for mmWave 5G to address connectivity gaps after achieving record data rates over a distance of 10km in trials with Australian operator NBN Co. The tests on NBN Co's fixed wireless access (FWA) network used eight component carriers to aggregate 800MHz of mmWave spectrum along with beamforming technology. Samsung stated the companies achieved average data rates of 1.75Gb/s in the downlink

and 61.5Mb/s up. Peak downlink data rate clocked in at 2.7Gb/s. Samsung used its 28MHz customer premise equipment in the trials, which combines a baseband, radio and antenna, and is compatible with all mmWave frequencies. As the longest FWA connection recorded by Samsung using the 28GHz band, the company said the trials showcase the potential of using the spectrum for wider rural coverage. NBN Co CTO Ray Owen explained in a joint release the results are "a significant milestone

and demonstrate how we are pushing the boundaries of innovation in support of the digital capabilities in Australia". He added the operator will be among the first in the world to deploy mmWave "at this scale". Lee June-hee, head of R&D for Samsung's Networks Business, stated the tests proved "the massive potential of mmWave technology and its ability to deliver enhanced connectivity and capacity for addressing the last mile challenges in rural areas".



T-Mobile US Lights Up SA 5G Using 2.5GHz

T-Mobile US has activated 5G Standalone (SA) services using its mid-band 2.5GHz 'Ultra Capacity' spectrum. Neville Ray, President of Technology at T-Mobile US, commented: '5G is making a meaningful impact today – changing the way people use their smartphones, bringing choice and competition to home broadband, improving disaster response and so much more ... but we're only scratching the surface on what 5G can do.' T-Mobile US initially switched on 5G SA in August 2020, using its 'Extended Range' 600MHz spectrum. T-Mobile's Extended Range 5G now covers 321 million people across 1.9 million square miles, while 250 million people are covered by the cellco's Ultra Capacity 5G network. Going forward, T-Mobile plans to reach 300 million people with Ultra Capacity spectrum next year.

InterDigital Scores EU Funds for 6G Research

InterDigital racked up another win around 6G research, securing European Union (EU) funding covering five of 35 projects as part of a €250 million initiative to advance the region's role in the evolution beyond 5G. The US mobile R&D company won backing to explore AI-enabled radio access; Digital Twins; short-range communications protocols; validation tools for potential 6G technologies; and another verification project covering reconfigurable intelligent surfaces and cell-free Massive MIMO. InterDigital stated the funding is being provided by the EU's Smart Networks and Services Joint Undertaking, an initiative forming part of the Horizon Europe 6G Flagship project. The EU network unit is running the latest 35-project program in conjunction with the 6G-IA, an association which describes itself as the private element in the Horizon 2020 5G Public Private Partnership. InterDigital's selection builds on its participation in 6G@UT, a project in the US led by the University of Texas announced in 2021. The company's CTO Rajesh Pankaj stated its participation in the EU project validated its previous

"contributions to the European wireless research and innovation ecosystem", referencing its work in previous 5G programs.



Canadian Government Backs EXFO 5G Research

Canada-based testing and monitoring equipment maker EXFO received CAD15.9 million (\$11.7 million) from the government to

accelerate development of 5G in the country by constructing a dedicated research facility. The company stated it would use the capital to build a 5G Centre of Excellence in Montreal, creating 50 jobs alongside the research boost. Canada's Ministry of Innovation, Science and Economic Development provided the sum through a strategic innovation funding scheme. EXFO CEO Philippe Morin stated the financial backing would allow the company to employ advanced cloud computing, AI and machine learning technologies to develop systems to automatically predict and detect problems on 5G networks. Nokia partnered with various government entities in Canada during October to construct what it claimed would be a world-leading R&D facility to advance AI, 5G, cybersecurity and environmental initiatives. [\[6\]](#)





Energy Management in Telecom

The Energy Management System (EnMS) is a framework for energy consumers, including industrial, commercial and public sector organizations, to manage their energy use.

The Energy management software reports and monitors energy system usage in towers, saving money on energy costs. The solution include real-time energy usage monitoring, energy data analytics, HVAC systems controls, and carbon and sustainability reporting.

The software also contains tools that alter energy usage to promote more efficient consumption and reduce carbon emissions.

It is designed to improve efficiency, ensure regulatory compliance, and reduce operational costs.

Value Proposition



Lowered Carbon
Footprint



Energy Efficiency



Renewable Energy



Cost Savings

ARTICLE

Digitalization and Sustainability to Revolutionize Telecom Energy Management



Sandeep Chandna
Chief Sustainability Officer
Tech Mahindra

Tech
Mahindra

Global climate change, caused by increased CO₂ and greenhouse gas emissions is one of the most serious global concerns. The primary source of these emissions is the energy sourced from the use of fossil fuels and it is no surprise that telecom operators are some of the biggest energy users in the world. Telecom Towers and Data Centers constitute for more than 70% of energy consumption in telecom sector. Overall, the current reality is that telecom operators account for 2 to 3 percent of total global energy demand.

"Telecom companies can find additional opportunities to increase revenue and enhance their contribution to environment & society by reinvigorating the ESG factors: Cost reduction, keeping customers satisfied whilst lowering their impact on the environment...all aspects must be taken into account. In this sense, sustainability is an important topic that should not be disregarded."

With the rise of 5G technology and the expected increase in network traffic, it is no surprise that telecom energy usage will skyrocket and the carbon footprint it leaves will grow, eventually. As per industry estimates, 5G spectrum bands consume twice as much energy as 4G's, although they are said to be more energy-efficient per gigabyte. The potential increase in data traffic (up to 1,000 times more) and the infrastructure to cope with it in the 5G era could make 5G to, arguably, consume up to 2-3 times as much energy. This potential increase in energy, coming from a high number of base stations, retail stores and office space, maintaining legacy plus 5G networks and the increasing cost of energy supply – call for action.

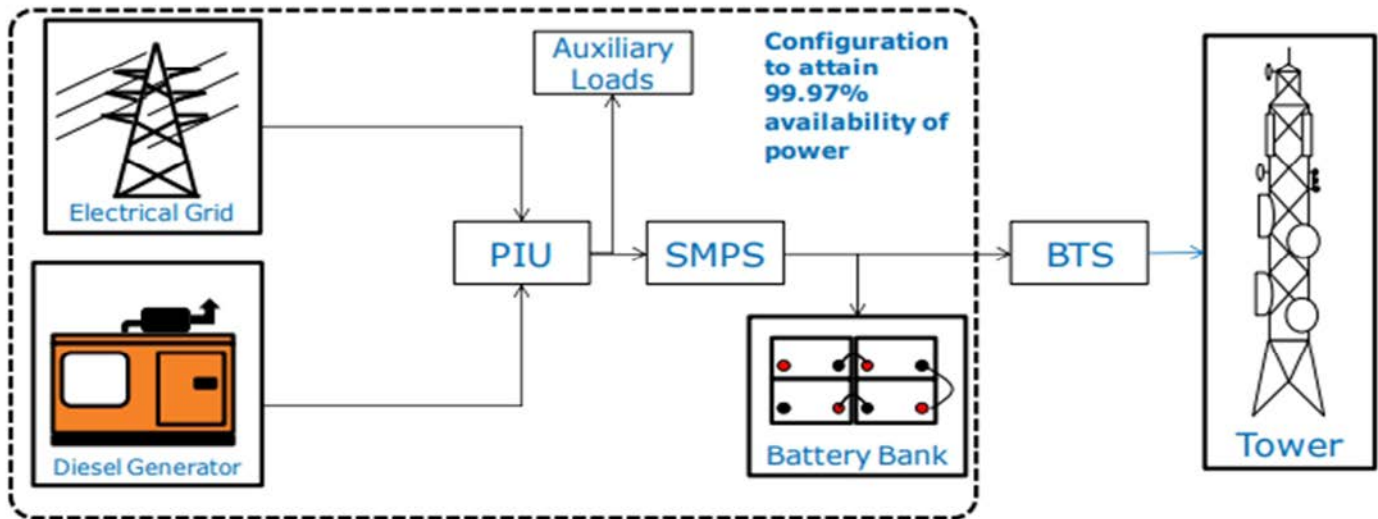

Fig. A Typical Telecom Tower site

Hence, making telecom networks more energy efficient is not only necessary to fight against global climate change, but with energy prices going up it is also a viable source of improved profitability. These changes also represent a great opportunity to reduce expenses, as implementing energy efficiency measures could potentially lower telecom operational costs by up to 20%.

Critical to Switch to Renewable Sources of Energy

To make up for the demand-supply gap, telecom tower operators use diesel generators, batteries, and a variety of power tools. The resulting energy costs alone account for 20-40% of the total network operating costs, affecting the profitability of the operators, thereby making the current use of diesel generators both an environmentally and economically unattractive solution. Hence, replacing lesser efficient fuel sources like Diesel with more efficient sources like Grid supply can lead to enhanced energy efficiency for telecom sector. Therefore, with the climate emergency hitting us hard, it is high time that stakeholders across industries adopt sustainable sources of energy to drive inclusive growth.

Green Energy to Improve Profitability

At a typical cell tower, the power demand is determined by the number of base transceiver stations (BTS) housed. The power demand ranges from 1 kW to 8.5 kW where more than 80% of these configurations have a demand of less than 3.5 kW. To ensure power availability of more than 99.95%, tower owners' backup the electrical grid with a combination of batteries and diesel generators.

Actions to Take Today

There isn't a magic bullet for lowering exorbitant energy usage in telecom networks. There are, however, steps operators can take to reduce the power they use and shrink their electricity bills. The most obvious and widely used solution is to switch all DC (Direct Current) power systems at access sites to high-efficiency rectifiers.

Replacing legacy DC power systems with newer, high-efficiency models can improve energy efficiency by 5-6% as high-efficiency rectifiers are smarter and better able to manage energy than legacy systems. However, operators often choose to ignore these features in favor of static operation.

It is imperative today that every provisioning decision at 5G site retrofit or new deployment should be made with

energy efficiency at the top of the mind. This should be the baseline expectation of operators everywhere.

There isn't a magic bullet for lowering exorbitant energy usage in telecom networks. There are, however, steps operators can take to reduce the power they use and shrink their electricity bills. The most obvious and widely used solution is to switch all DC (Direct Current) power systems at access sites to high-efficiency rectifiers.

It's Now or Never

By 2040, the telecom industry could be responsible for up to 14% of the world's CO₂ emissions, according to an industry report. It is high time that we make it our collective goal to save our environment by leveraging technology to combat climate change and scaling up the use of renewable energy. 🌱

REGULATORY NEWS

ITU Telecommunication Development Sector (ITU-D) Study Groups Address Meaningful Connectivity and Digital Transformation

The first meetings of Study Groups 1 and 2 in the ITU Telecommunication Development Sector (ITU-D) for the 2022-2025 study period took place in Geneva, Switzerland, and online, with focus on meaningful connectivity and digital transformation. The study groups addressed 14 new study Questions adopted at WTDC that range from deploying broadband in developing countries to considering ICTs for the environment. The meetings for Study Groups 1 and 2 took place from 28 November to 2 December and from 5 to 9 December respectively. "ITU-D study groups provide the opportunity to consider the most pressing issues related to telecommunication and development," said ITU Secretary-General Houlin Zhao. "Participants at these meetings are doing their part to ensure that technology is used for the greatest possible human benefit." ITU-D study groups allow ITU members focused on digital development to share knowledge, experiences, and innovative ideas on how information and communication technologies (ICTs) can help meet the UN Sustainable Development Goals. The study groups produce reports, guidelines, and recommendations to help countries, companies and other organizations

implement telecommunication/ICT policies, strategies, projects and initiatives. "Study groups are an integral part of ITU's work to promote digital transformation for all," said Doreen Bogdan-Martin, Director of the Telecommunication Development Bureau and ITU Secretary-General-elect. "These pivotal meetings help steer the conversation about the future of information and communication technologies and help us explore new possibilities for a brighter and more inclusive world for all." Discussions hosted by the International Telecommunication Union (ITU) focused on each group's designated topics: "Enabling environment for meaningful connectivity" for Study Group 1 and "Digital transformation" for Study Group 2. The new study Questions for the two ITU-D study groups were adopted at the World Telecommunication Development Conference (WTDC) in Kigali, Rwanda, from 6 to 16 June 2022. Each study group addressed seven of the new study Questions. Key decisions taken during the meetings included:

- The appointment of ITU-D Study Group 1 and 2 rapporteurs, co-rapporteurs, and vice-rapporteurs and approval of work plans for study Questions.

- Assignment of specific coordination roles in order to address cross-cutting items in line with WTDC Resolutions.
- Development of initial workplans and table of contents (living documents), which will help guide future work of the rapporteur groups.

Advancing toward gender parity priorities for the meetings, ITU-D Study Group 1 and 2 comprised 48 per cent and 42 per cent female participants respectively. To ensure younger participation and perspectives, two groups of six youth envoys from ITU's Generation Connect initiative participated in the meetings of both study groups. The youth envoys, sponsored by the United States Telecommunications Training Institute (USTTI), engaged in the ITU-D study group process and received on-site training from their respective national delegations. Two intergenerational dialogues on the side-lines of the meetings let the youth envoys share thoughts on the topics being discussed. Study Group 1 featured a discussion on "Youth Advancing Meaningful Connectivity," while Study Group 2 featured "Youth Empowerment for Digital Transformation."



Internet More Affordable and Widespread, but World's Poorest Still Shut Off from Online Opportunities

The cost of Internet services has inched downward across the globe in 2022, according to Facts and Figures, the annual worldwide overview on the state of digital connectivity from the International Telecommunication Union (ITU). The Internet has become more affordable in all regions of the world and among all income groups, based on the assessment from ITU, the United Nations specialized agency for information and communication technologies (ICTs). Cost, however, remains a major obstacle to Internet access, especially in low-income economies. The current global economic situation – with high inflation, rising interest rates, and deep uncertainty – could add to the challenge of extending Internet reach in lower-income areas. “The Internet may be more affordable overall, but for billions of people around the world, it is just as out of reach as ever,” said ITU Secretary-General Houlin Zhao. “We need to keep Internet affordability moving in the right direction even as the global downturn cuts deeper into the economic prospects of many countries.” ITU’s Facts and Figures series features estimates for key connectivity indicators for the world, regions, and selected country groups. The assessment provides context on the evolving digital divide while also reviewing progress towards closing it. Earlier this year, ITU reported that 2.7 billion people – roughly one-third of the global population – remain unconnected to the Internet. The figure was an improvement from 2021 but revealed a levelling off from the strong connectivity gains made during the onset and height of the COVID-19 pandemic. “Access to the Internet is increasing, but not as quickly and evenly across the world as it needs to,” said Doreen Bogdan-Martin, Director of ITU’s Telecommunication Development Bureau and ITU Secretary-General-elect. “Too many people still live in digital darkness. Our global challenge is to commit the resources that would allow everyone to benefit in a meaningful way from being connected.” According to Facts and Figures 2022, the global median price of mobile-broadband services dropped from 1.9 per cent to 1.5 per cent of average gross national income (GNI) per capita. Mobile broadband allows users to access

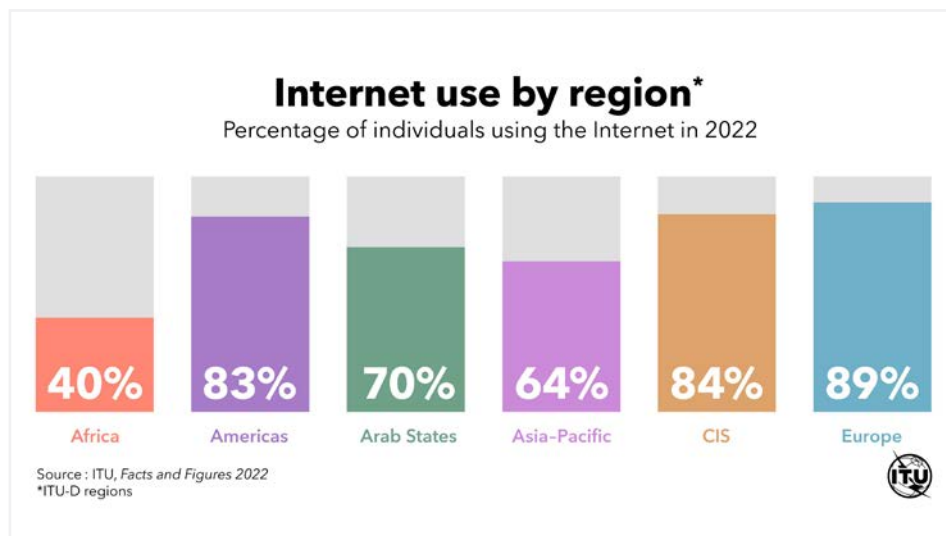

the Internet from a smartphone. The affordability of this service has become a benchmark for global Internet use, since it provides relatively inexpensive access compared to fixed Internet service. Still, for the average consumer in most low-income economies, the cost of fixed or mobile broadband services remains too high. A basic mobile data plan in these countries was found to cost on average 9 per cent of average income. This represents a slight decrease from 2021, but it remains many times greater than the cost of similar services in higher-income countries. The result is that those who can least afford broadband service – and that could benefit the most from it – are paying the highest amounts in relative terms. Earlier this year, ITU and the Office of the UN Secretary-General’s Envoy on Technology announced ambitious targets for universal and meaningful digital connectivity to be achieved by 2030. Affordability, defined as the availability of broadband access at a price that is less than 2 per cent of monthly GNI per capita, was identified as a priority to ensure that everyone can benefit fully from connectivity. Among the economies for which data are available for both 2021 and 2022, more countries met the 2 per cent affordability target in 2022 across the different types of services. Although women account for close to half the world’s population, 259 million fewer women have access to the Internet than men. Only 63 per cent of women are using the Internet

in 2022 compared to 69 per cent of men, according to Facts and Figures 2022. The gender gap is even more concerning in lower-income nations in which 21 per cent of women are online compared to 32 per cent of men, a figure that has not improved since 2019. Overall, the world has moved closer toward gender parity over the last three years. Gender parity is defined as when the female percentage of Internet users divided by the male percentage stands between 0.98 and 1.02. The gender parity score improved from 0.90 in 2019 to 0.92 in 2022. Generally, regions with the highest Internet use also have the highest gender parity scores. Conversely, many of the world’s least developed and vulnerable economies feature low Internet use, a low gender parity score, and limited progress toward gender parity over the last three years. For the first time, ITU’s Facts and Figures features global and regional estimates for mobile phone ownership, revealing that almost three-quarters of the global population aged 10 and over own a mobile phone in 2022. Mobile phones are the most common gateway to Internet use, with the percentage of ownership serving as an indicator of Internet availability and access. Ownership of mobile phones, however, remains higher than Internet use, especially in lower-income countries. Reliance on mobile-cellular service could be a further indication of the impact of costs, with overall prices for cellular-only service being less expensive than

broadband. According to Facts and Figures 2022, youth aged 15-24 years are the driving force of connectivity, with 75 per cent of young people worldwide now able to use the Internet, up from 72 per cent in 2021. Use among the rest of the population is estimated at 65 per cent. Universality, defined as more than 95 per cent Internet use, has already been reached among the youth 15-24 age group in high- and upper-

middle-income economies. Low-income economies feature the biggest generation gap, with 39 per cent of young people using the Internet, compared to only 23 per cent of the rest of the population. Among other findings in Facts and Figures 2022, mobile-broadband subscriptions continue to grow fast and are approaching mobile-cellular subscription rates, which are plateauing. Fixed broadband subscriptions

also continue to grow steadily, but low digital skills remain an obstacle that keeps individuals from fully realizing the benefits of being online, as well as limiting their ability to avoid its dangers. Detailed global, regional, and country-level analysis for five price plans tracked by ITU, as well as the full 2022 country-level dataset for ICT prices, will be released in 2023.

World Radiocommunication Seminar Shows How ITU Radio Regulations Drive Global Communications

The biennial ITU World Radiocommunication Seminar (WRS) returned to Geneva for an in-person capacity building program. At the event, participants received hands-on training on the application of Radio Regulations and the equitable access to the radio-frequency spectrum and associated satellite orbits for space services. For the second time, the WRS Plenary Sessions were open to everyone, including entities that are not members of the ITU Radiocommunication Sector (ITU-R). Overall, 427 individuals from 92 countries took part in activities offered during the week-long event. Together with Regional Radiocommunication Seminars, World Radiocommunication Seminars provide an opportunity to gain deeper insight into the Radio Regulations as revised by the last World Radiocommunication Conference in 2019. These seminars, held every two years for ITU members worldwide, also aim to provide participants with essential technical and regulatory background information to assist them as they prepare for the next ITU World Radiocommunication Conference, to be held in Dubai, United Arab Emirates, from 20 November to 15 December 2023. "The World Radiocommunication Seminar

is an excellent opportunity to become familiar with the procedures that regulate and govern the use of the radio-frequency spectrum and satellite orbits," said ITU Secretary-General Houlin Zhao. "Capacity building remains a key component of ITU's engagement with all our members so that they can leverage the benefits of information and communication technology and advance digital transformation for all." The seminar covered topics related to spectrum management at global, regional, and national levels. Participants were presented with an overview of the ITU Radio Regulations (2020 Version), to help them better understand the regulatory framework for terrestrial and space radiocommunication services including frequency allocations, the filing process for obtaining new frequency assignments, along with related software and tools. Participants were also updated on the current activities and hot topics being undertaken by the ITU Radiocommunication Study Groups. Regarding the importance of World and Regional Radiocommunication Seminars, Mario Maniewicz, Director of the ITU Radiocommunication Bureau, explained:

"The Radio Regulations provide an international regulatory framework for the introduction of new, innovative technologies while simultaneously ensuring that all radio systems can coexist without receiving harmful interference. It is therefore critical that countries understand how to apply these regulations to build robust digital systems that benefit people everywhere." The WRS-22 Plenary sessions covered radiocommunication-related matters, application of ITU Radio Regulations and trends in various radiocommunication services. Participants were also introduced to the activities and work of the ITU-R Study Groups, the Radio Regulations Board, the Radiocommunication Assembly (RA) and the World Radiocommunication Conference (WRC). During the WRS-22 space and terrestrial workshops held over four days, participants received hands-on experience with ITU notification procedures as well as with the software, databases and electronic publications made available by the Radiocommunication Bureau to the ITU membership. Tailored sessions were also available for both beginners and advanced users of BR software tools.



Space and Air-Based Networks are Key to Reaching the 2.7 Billion People Still Unconnected Worldwide



Advances in space and satellite technology combined with evolving wireless connectivity are essential to connect people who remain excluded from the digital revolution, according to participants at the recently concluded "Connecting the World from the Skies" forum. The forum, organized by the International Telecommunication Union (ITU) and Saudi Arabia's Communications, Space and Technology Commission, brought radiocommunication and space industry experts together to explore new ways to enhance global digital connectivity. The three-day forum took place in Riyadh, Saudi Arabia, from 8 to 10 November. "Digital networks and technologies continue to empower and enrich the lives of billions of people worldwide," said ITU Secretary-General Houlin Zhao. "While many parts of the globe are connected, there is still much work to do to bring in the remaining third of the world's population. Innovative aerial and spaceborne communication networks have the potential to advance our efforts to bridge the digital divide at country and global levels." Recognizing the need to reach the 2.7 billion people still unconnected around the world, the public-private forum focused on technological

developments and innovative business models for aerial and space-based connectivity. It also highlighted how regulators and governments are working alongside industry to unleash untapped potential in today's 5G networks, as well as in the journey towards 6G. "Access to affordable broadband connectivity should be the norm and not a privilege," said Mohammed Altamimi, Governor of the Communications, Space and Technology Commission. "More than ever, we need to build bridges between industry and public sector, to enhance collaboration and leverage innovative technology to ensure the global digital economy leaves no one behind."

Policy and industry coordination on air and space networks

"Connecting the World from the Skies" included participants from the public and private sectors, including radiocommunication and space industry innovators, researchers, and policy makers from national regulators and international bodies. At the high-level opening session, technology ministers discussed the challenges and opportunities of delivering connectivity from the skies with policy and industry leaders. Among the topics

covered were the evolution of satellites to provide fixed or mobile connectivity directly to devices, and air-to-ground technology capabilities to bring broadband connectivity to airplanes. Future space- and air-based technologies may require additional radio-frequency spectrum allocations, along with harmonized standards and dedicated regulatory frameworks. All these elements call for accelerated collaboration across sectors. Forum participants showcased a variety of technological solutions that can provide connectivity through airborne and spaceborne networks.

Build-up to the next World Radiocommunication Conference, WRC-23

Coming just over a year ahead of the next World Radiocommunication Conference (WRC-23), the forum emphasized the need to undertake environmental impact studies of new technologies. Participants also highlighted the possible adoption of green standards for information and communication technology to reduce space debris and light pollution. "This forum raised some of the critical issues that ITU members will consider at the next WRC," said Mario Maniewicz, Director of the ITU Radiocommunication Bureau. "Reaching the unconnected will require an innovative combination of fixed, terrestrial and satellite networks, not only to provide service continuity but also to strengthen service availability and provide ubiquitous, seamless coverage everywhere." WRC-23 will take place in Dubai, United Arab Emirates, from 20 November to 15 December 2023. At the conference in Dubai, ITU Member States will consider provision of additional spectrum for new applications and satellite systems, and establish an international regulatory framework to allow satellite systems to also deliver services to moving earth stations irrespective of whether they operate on ground, air or at sea. WRC-23 will also consider regulatory actions for the provision for inter-satellite links and will improve the regulatory procedures for non-geostationary systems. 🌐



Global Trends

a new intelligence service by Cullen International

Get expert insight
on the global tech trends
at the top of the agenda
for regulators &
policymakers

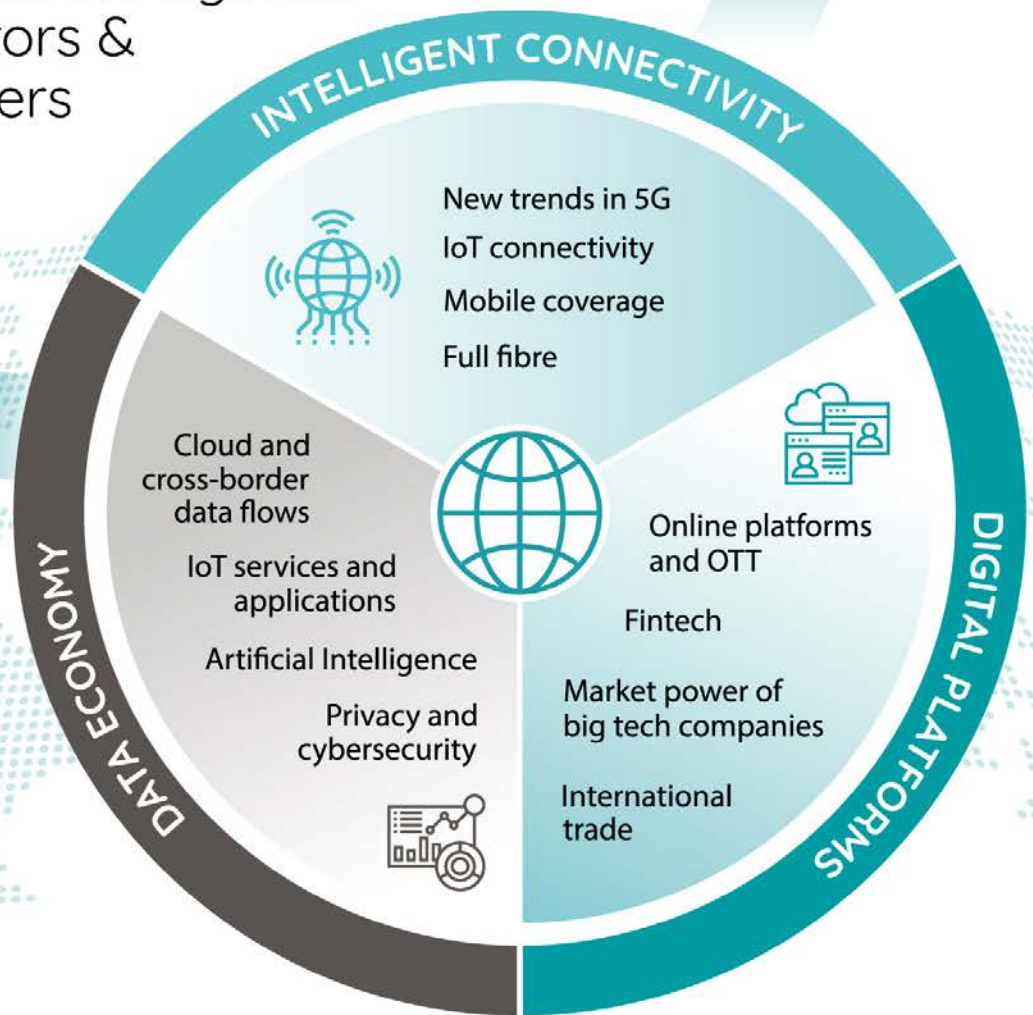

See more examples and find out how our intelligence could help you with a free personal demo:
<https://pages.cullen-international.com/GT>

www.cullen-international.com

regulation made simple

A SNAPSHOT OF REGULATORY ACTIVITIES IN THE SAMENA REGION



Bahrain

The Information & eGovernment Authority (iGA) has held a national workshop on capacity building in implementing technology for developing price statistics. During the workshop, participants were introduced to the latest technologies to be used in price collection from outlets. The collected prices are used to compile the Consumer Price Index (CPI) and the Purchasing Power Parity (PPP). The workshop was held in line with the regional cooperative initiatives framework between the Kingdom of Bahrain and the Economic and Social Commission for Western Asia (ESCWA). Implementing such technology in the price collection process will improve the data quality, increase the pace of data collection and increase efficiency. iGA Director of Economic Statistics Noora Khamis Al-Saadoon explained that such workshops are in line with the authority's vision to employ the latest technologies and use the Big Data and other innovative methodologies to improve the credibility and quality of the collected data. During the three-day workshop, participants were introduced to the most recent technology, methods of implementing them in the field of price statistics, their advantages, and the challenges facing their implementation. Moreover, participants were also practice the new technology extracting the data from different types of e-commerce outlets. (December 4, 2022) www.tradearabia.com

The Telecommunications Regulatory Authority (TRA) has made part of the C-band spectrum available for 5G private networks, in line with the goals outlined in its Workplan for the 2022-23 period. By making spectrum available in the 3.8GHz-4.2GHz band, the regulator says it will ensure maximum flexibility while protecting existing systems and optimizing both the short and long-term use of the frequencies. Licenses will be available to businesses, government users and licensed operators, 'allowing

them to determine the best ways of utilizing wireless technologies to support their digitization plans'. The TRA will also launch a program to ensure that users can reap the benefits of wireless technologies while incorporating them into the digitization of their operations. (December 1, 2022) www.commsupdate.com

The Telecommunications Regulatory Authority (TRA) has made part of the C-Band spectrum available for 5G Private Networks, placing Bahrain at the forefront of GCC countries in enabling both private and public sectors to benefit from the latest technologies. The move is in line with the TRA's commitment to realizing the ambitious goals outlined in its Workplan. By being the first country in the GCC to lead this initiative, it will further cement the Kingdom's reputation for leadership in the digital market, having already achieved 100% 5G commercial network coverage. In making the spectrum available, the TRA will ensure maximum flexibility while protecting existing systems and optimize both the short and long-term use of the spectrum. TRA General Director Philip Marnick said: "The Kingdom of Bahrain remains one of the most well-connected places globally. Not only does 5G technology enable better mobile broadband for consumers, it also supports industrial applications. To ensure the Kingdom can take full advantage of the potential of wireless technology, the TRA is making spectrum available in the 3.8 to 4.2GHz band to support private network services." The licenses will be available to businesses, government users, and licensed operators, allowing them to determine the best ways of utilizing wireless technologies to support their digitization plans. The TRA will also launch a program to ensure users can reap the benefits of wireless technologies while incorporating them into the digitization of their operation.

(November 29,2022) www.tra.org.bh



Bangladesh

The telecom regulator launched a new benchmarking system to ensure standard voice and internet services for the customers. The Bangladesh Telecommunication Regulatory Commission launched the new system at a press conference at its office in Dhaka. The new system was acquired from German-based company Rohde & Schwarz, said Brigadier General Md Ehsanul Kabir, director general at engineering and operations division at the commission. The benchmarking system will enable BTRC to test the service quality of the mobile network operators in four divisions at a time with

four units of the system, he said. Two vehicle-mounted chassis-based systems and two backpack-based systems will be used to measure the service quality in different parts of the country, Kabir said. Each of the two vehicles is mounted a chassis-based system equipped with 24 terminals. They can measure service quality of 2G, 3G and 4G voice calls, 3G and 4G data speed, 'over the top' apps (OTT) of all operators and the service quality of Google and WhatsApp. Through the backpack-based systems, the quality of mobile phone services can be easily checked in outdoor places as

well as in different indoor locations (inside markets, basements of different buildings, houses and offices etc.). Scanners are attached to each of the four units, enabling them to check the status of network coverage such as mobile network signal strength or weakness at any location. The total cost of the project was 15 lakh euro. "Last year it took us 9 months to test the service quality of

the mobile network operator throughout the country. But now we will be able to do it within just two months," said Kabir. He said the new system will also be able to measure 5G service quality. Mustafa Jabbar, Telecom Minister, and Md Mohiuddin Ahmed, Vice Chairman of the BTRC, also spoke.

(November 6, 2022) www.thedailystar.net



Egypt

Held by the National Telecommunications Regulatory Authority of Egypt (NTRA), and with the participation of 13 African and Arab countries, proceedings of the Egyptian African Telecom Regulatory Center's (EG-ATRC) fourth training session commenced. EG-ATRC is held in line with NTRA's plan to build African cadres in telecommunications as well as exchange expertise, technical and commercial practices with African counterparts in telecom authorities. It also comes in line with the Government's instructions to reinforce relations with African countries. Training topics to be embarked upon in EG-ATRC's fourth session are radio spectrum, type approval and licensing. The session's agenda also provides opportunities for seamless communication among African experts to exchange insights and utilize the leading experience of Egypt in telecom regulation. It's worth noting that NTRA had inaugurated EG-ATRC as the first of its kind in Africa to provide training courses in telecom regulation. It actually paves the road for telecom experience to be exchanged across the African countries and aims to achieve a unified vision among telecom regulators, and other relevant African entities, through a specialized training program which encompasses many academic and professional experts from Egypt and would consequently contribute to building a promising digital economy across Africa. Furthermore, EG-ATRC aims to provide training courses for 150 specialized individuals annually, via specialized training courses designed and taught by an elite of international experts.

(November 28, 2022) www.tra.gov.eg

The National Telecommunications Regulatory Authority of Egypt (NTRA), in cooperation with the Information Technology Industry Development Agency (ITIDA), held Egypt's first forum for Internet of Things (IoT) services. The Forum was held with 75 participants taking part as representatives of 36 public, private, and business sectors, in addition to leading technology manufacturers as well as operators. It aims to foster and disseminate IoT services within

Egypt's market, particularly across the national projects carried out and the smart ecosystems applied in the state's developmental sectors. This also comes in line with NTRA's role to uphold the state's strategies which aim at reinforcing digital transformation and disseminating modern technologies across the state's different sectors, and attracting as well as increasing investments in digital services. Participants discussed the market's recent updates with regard to IoT services, at the top of which was the IoT framework established by NTRA at the beginning of this year. They also gave their visions and recommendations, and discussed the challenges hindering IoT services from being used nationwide. Furthermore, industry-specific suggestions as well as plans to prepare technical IoT cadres were discussed; small and intermediate entrepreneurs were also encouraged to use modern technology with an aim to develop technical solutions in all fields. The Forum's work groups and mechanisms, including two main agendas, were also approved. The first agenda handles securing data, establishing regulatory as well as legislative frameworks, creating awareness and providing a suitable environment to prepare specialized human cadres. Meanwhile, the second agenda takes on widely using IoT services in public utilities such as, health, education, environment, transportation, tourism, energy, industry, agriculture, irrigation and smart cities sectors. NTRA had previously established the IoT regulatory framework to provide IoT services within the Arab Republic of Egypt, being a significant mainstay of Industry 4.0. In fact, IoT facilitates operating smart cities' systems, smart meters and smart transportation schemes, in addition to providing digital services across the state's multi-sectors. It's worth noting that IoT encompasses all inter-connected devices via telecom networks to exchange data, in order to meet the citizens' requirements in all life aspects. IoT apps are also diversified in accordance with the nature of each service including, end-user, trade and industrial, infrastructural and governmental activities.

(November 27, 2022) www.tra.gov.eg



Iran

Iran's Ministry of ICT says work has begun on deploying fiber access networks in ten provincial centers and 55 other cities across the country. A report from ISNA says some two million premises are already passed by fiber-optic infrastructure. 70,000km of fiber

has so far been deployed across Iran and authorities are hoping to oversee the rollout of minimum 25Mbps broadband speeds to 80% of households and 100% of businesses by 2025.

(November 29, 2022) www.commsupdate.com



Jordan

Telecommunications Regulatory Commission (TRC) confirmed that the license for "satellite Internet" services is available in Jordan within the legislations and instructions governing the TRC. TRC expected, "Satellite Internet" services will be commercially operated initially by the end of the third quarter of next year, after the company formally submits licensing applications. Chairman of the Board of Commissioners of the TRC, Bassam Sarhan, announced on October 31, 2022, the success of the experiment conducted by SpaceX in launching "satellite Internet" services through satellites in low orbits, recording high numbers and speeds in the average data download speeds, ranging from 100MB and 200MB. TRC said that it is working to diversify telecommunications services in the Jordanian telecom market with the aim of providing the best services to beneficiaries in accordance with the royal vision aimed at developing and strengthening the sector, by continuing to work to create a stimulating investment environment. "Satellite Internet services will target covering remote areas and areas with sparsely populated areas, including uses for mining and drilling sites and tourist sites", TRC added. SpaceX is one of the leading companies in the field of providing Internet services by launching several satellites for this purpose, according to TRC.

(December 8, 2022) <https://en.ammonnews.net>

Jordan's Telecommunication Regulatory Commission (TRC) has started work updating the methodology for calculating interconnection fees using a Total Service Long Run Incremental Cost Plus (TSLRIC+) model.

The watchdog notes that the update is intended to stimulate effective competitive by ensuring that interconnection fees are based on the cost of those services for future periods and taking into account the higher efficiency standards within the market in calculating those rates. The project is being carried out with assistance from Axon Consulting although the TRC adds that the joint team of regulatory officials and consultants will be in a 'continuous dialogue' with licensed providers. The project is expected to take around a year and will be implemented in several phases. Interconnection fees were last reviewed in 2017 and pricing models established at that time covered the period from 2018 to 2021. (November 21, 2022) www.commsupdate.com

Minister of Digital Economy and Entrepreneurship Ahmad Hanandeh said that the three telecommunications companies operating in Jordan are obliged, as per the term of an agreement they signed, to introduce the 5G service in Jordan within 18 months, according to Jo24. Hanandeh added that the companies are currently preparing to modernize their networks, in compliance with the conditions stipulated in the agreement, noting that if they do not do it within the specified date, the agreement will be cancelled. According to Hanandeh, companies are currently selecting suppliers to modernize networks and introducing the 5G service to the Kingdom. The agreement grants signatories

licenses to access 5G frequencies, so each licensee is obliged to launch 5G services commercially within a period not exceeding 18 months from the date it obtained the license. Each licensee has the obligation to provide 5G services, make them available to at least 50 percent of the population within a period not exceeding four years from the licensing date, and increase the coverage rate by 5 percent each year, until no less than 75 percent of the population is covered. The government, represented by the Telecommunications Regulatory Commission (TRC), will receive 10 percent of the revenues from the 5G services and applications provided by the licensed companies. The incentive packages granted to companies include exemption from sales tax and customs duties on the infrastructure components, devices and equipment for the 5G service networks, showing no partiality to any licensee, and granting applicants for a license a one-time discount of 50 percent on the proceeds from acquiring an additional frequency license. Any such future license will be approved only within the frequency bands the companies are currently licensed for. The package also includes extending valid licenses, with Cabinet approval, for an additional 10 years, only for one time, provided there is compliance with the obligations stipulated in the agreement. TRC will then evaluate whether the licensees have performed in accordance with the bases and performance indicators set forth in the agreement for the purpose of extending their licenses for five more years, and for one time only, in addition to ensuring that the government's annual revenues from telecommunications services will increase constantly in 2022, 2023 and 2024, or the renewal will not be granted. Revenues from the activities and services of 2G, 3G and 4G will be modified in accordance with a previous Cabinet decision to become 6 percent instead of 10 percent. Meanwhile, revenues from the provision of 5G services and/or any services associated with, complementary to, or derived from the service, will stand at 10 percent. (November 13, 2022) www.jordannews.jo

American aerospace company SpaceX has tested its flagship satellite internet service, Starlink, in southern Jordan, and recorded download speeds of 100 to 200 Mbps, according to a statement released by the Jordan Telecommunications Regulatory Commission (TRC). According to TRC, this is the first test of its kind for the American company in the Middle East, where the Starlink service is still unavailable. This satellite Internet service is currently available in the United States, Canada, much of Europe, Australia, Japan, and parts of South America, according to an interactive map of the world on the Starlink website. TRC added that it welcomes conducting technical tests of telecommunication services in sparsely populated, remote areas where the Internet and communications are currently not available. SpaceX started launching Starlink satellites in 2019. As of September 2022, Starlink consists of over 3,000 mass-produced small satellites in low Earth orbit, which communicate with designated ground transceivers. (November 2, 2022) www.en.ammonnews.net



Kuwait

Kuwaiti newspapers including The Times, Al-Qabas and Arab Times are reporting that the Ministry of Communications (MoC) and the local division of Nokia have begun work on delayed fiber-optic network projects including the replacement of copper lines with high speed fiber to improve the quality of telephone and internet services in several areas. The MoC disclosed that the most recent work has been completed in the Al-Bida area while planning is under way to start modernizing other earmarked areas under a two-year contract signed in May. The MoC's initial GPON fibre network deployed in 2006 was belatedly expanded in 2018; Phase II of the GPON project was completed in October 2018, when the MoC claimed that the infrastructure covered 55% of Kuwaiti households, while Phase III has since remained in the early stages.

(December 21, 2022) www.commsupdate.com

The quality of internet services in Kuwait has significantly improved over the past two years, thanks to 4G and 5G networks. Before 2020, Kuwait's 4G experience trailed leading 4G telecom markets such as Korea & Singapore, with an average download speed of 40 to 50 Mbps. A massive shift has since occurred, with the 4G user experience speed increasing 2.76 times from 6 Mbps in 2015 to 16.2 Mbps in 2019, based on independent OpenSignal reports. Mobile broadband dominates internet access in Kuwait due to low fiber penetration; CITRA's latest figures show that 84.8% of Kuwaiti families access the internet through their mobile devices. Mobile broadband penetration now exceeds 100% in Kuwait. Operators have invested significantly in infrastructure to sustain

this growth. Large-scale 3G to 4G user migration quickly drove 4G to the maturity stage and spearheaded a true smartphone revolution. Multimedia sharing, social media, e-commerce and online gaming powered by 4G laid the foundation for the eventual 5G roll-out. The Kuwaiti telecom market has traditionally been very competitive. An HSDPA 7.2 Mbps service was available as early as 2007, followed by the region's first nationwide 4G network in 2013. Meanwhile, Kuwait launched the region's first commercial 5G service in 2019. Operators have since rolled out the region's first commercial deployment of advanced 5G technologies to enable better 5G indoor customer reach and additional 5G capacity to cater to the unexpected 30% surge in traffic during the pandemic. Ookla highlighted in their recent report that Kuwait has the region's highest 5G network availability at 35%. Kuwait ranks within a list of top six countries with the fastest 5G worldwide, while "Kuwait City" ranks as the fastest city in the world. In addition to 5G quality of service development, Opensignal shows that 4G internet speed reached around 40 Mbps average download speeds and 94.4% 4G availability, respectively, in February 2022. Kuwait networks are, therefore, one of the leading mobile broadbands worldwide, based on global user experience platforms. Mobile operators' continuous 4G and 5G network improvement measures have provided noticeable capacity improvement in Kuwait's 4G and 5G Mobile infrastructure. CITRA's latest QoS Audit network report shows that 4G/5G Internet services from the three operators improved significantly in 2021.

(November 30, 2022) teletimesinternational.com



Nepal

Nepal Telecom (NT), the country's largest mobile network operator (MNO) by subscriptions, has begun preliminary testing of 5G mobile services from two base transceiver stations in Kathmandu. Confirming the company was preparing to launch the much-delayed trials from its offices in the Sundhara and Babarmahal areas of the capital, NT spokesperson Ranjot Lohiya noted services would be expanded to another three districts following successful conclusion of the pre-testing. The operator had planned to kick off 5G trials in mid-July 2021, but the timetable was delayed by a change of government which delayed assignment of the additional spectrum resources required. Having finally been granted a testing

permit and 60MHz of frequencies in the 2600MHz band the following November, NT then encountered further problems with equipment delivery. The operator now intends to conduct trials in all seven provinces of the country by the end of its current financial year (mid-July 2023), as the Nepal Telecommunications Authority (NTA) has expanded the scope of its initial testing plans. The frequencies will be exempt from standard spectrum fees during the twelve-month trial program on condition that NT's customers can access the service at no additional charge.

(November 16, 2022) www.commsupdate.com



Oman

The Telecommunications Regulatory Authority (TRA) held an annual media meeting to review its achievements of 2022 and to discuss its upcoming plans. Speaking on the achievements of the year 2022, Omar bin Hamdan al Ismaili, CEO of TRA, said that 12 regulations were issued this year to raise the quality of telecommunications services in the country. On the issue of disruption in telecom services, Ismaili, said that this is due to damages related to undersea cables. "We have to find alternative routes for these cables which require huge investment, apart from having regulations for the docking of ships." He added that a price report for telecom companies' services will be published next week, which has been prepared by an independent body to achieve transparency, and for companies to look at prices in the Arab region. TRA said that there is a program to close 3G networks so that service providers can use 3G spectrum capacities for new technologies such as 4G and 5G. It was revealed that nearly 80 per cent of buildings will be covered by fixed high-speed broadband,

noting that over 600,000 buildings are covered by fiber services in 2022. Around 51 per cent of buildings have been covered by fiber optic services and there are plans to cover 50,000 new buildings in 2023 with optical fiber networks", he added. TRA has a target to cover 75 per cent of the buildings in the country with an optical fiber network by 2025. According to TRA, the 5G and optic fiber services cover about 94 per cent of 880 schools. TRA said that the most important regulation issued in 2022 was regarding voice or video communication services via the Internet Protocol. The meeting said that the coverage of postal services in the country has reached 85 per cent and currently there are three international companies and 20 local companies operating in the country. TRA said it has dealt with more than 30,000 inquiries through all platforms available to the beneficiary with a 20-second average waiting time at the call center. An amount worth RO40,000 was refunded to beneficiaries, while 314 decisions were issued against telecommunications companies. (December 25, 2022) www.omanobserver.om



Pakistan

Pakistan Telecommunication Authority (PTA) has carried out independent Quality of Service (QoS) surveys in 09 cities of Punjab and Sindh and 13 motorways/highways of Pakistan. A survey was also conducted, jointly with Cellular Mobile Operators (CMOs), in 08 cities of Gilgit Baltistan. These surveys were undertaken to measure performance and quality of CMOs services being provided to their customers. The results revealed that CMOs are compliant with respect to data speeds to a great extent, while network latency and webpage loading time was found below the threshold. Similarly, some of the Voice KPIs have also been found below the licensed threshold in few areas. Necessary instructions have been issued to the operators for taking corrective measures to ensure improvement in service quality up to the KPIs. In accordance with Next Generation Mobile Service (NGMS) licenses and Cellular Mobile Network Quality of Service (QoS) Regulations 2021, mobile network coverage, QoS KPIs of Voice, SMS and Mobile Broadband were checked using state-of-the-art automated QoS Monitoring & Benchmarking Tool. The drive test teams selected survey routes to cover main roads, service roads and majority of sectors/colonies in surveyed areas. Based upon set KPIs against threshold defined in the respective licenses and QoS regulations, CMOs have been ranked between 1st to 5th position in Mobile Network Coverage and Voice Services in surveyed cities and roads/motorways. Similarly, in Mobile Broadband Speed segment, the ranking is with respect to highest data download and upload speed, network latency and webpage loading time. The service quality monitoring activity is carried out by PTA field teams with the ultimate aim to pursue the operators for provision of better mobile services and

promote a healthy competition among the operators.

(December 1, 2022) pta.gov.pk

The Pakistan Telecommunication Authority (PTA) has identified and blocked 4,395,566 Subscriber Identity Modules (SIMs) from 2020 to 2022 suspected of being involved in gray trafficking to safeguard potential loss. Gray traffic is essentially the concealment of incoming international telephone calls (traffic), which are terminated on fixed and mobile networks by using illegal channels and other means for the purpose of avoiding taxes and levies, adding that biometric verification is related to the proper issuance of SIMs and is not a direct measure to control gray traffic. Furthermore, gray traffic is terminated through mobile connections as well as other fixed-line termination channels. According to official documents, the PTA analyzes the traffic data of international incoming calls on a regular basis in order to identify SIMs suspected of being involved in gray traffic. Upon detection, these SIMs are blocked to safeguard against potential loss. Since 2020-22, a total of 4,395,566 such SIMs have been identified and blocked. Whereas, based upon irregularities observed in the issuance of a number of gray SIMs, a fine of Rs. 150 million has also been imposed on the respective cellular mobile operators (CMOs). However, no CMO itself has been identified as using such SIMs for gray traffic termination, as maintained in the documents. Official sources revealed that a significant decline has been observed in gray traffic since the deployment of the Web Management Solution (WMS), which blocks voice calls coming through unauthorized gray channels. Sources revealed that gray

trafficking, which has been reduced significantly, could not be ruled out completely despite biometric verification and posed a serious security threat. Gray SIMs are either issued by defrauding people through various means by getting their finger impressions in real-time or by misusing their captured finger impressions on silicon sheets in offline mode. To curb the menace of gray traffic, the PTA has adopted a comprehensive and multi-faceted approach. Some details are as follows:

- Strengthening of BVS to minimize misuse; these include the introduction of Live Finger Detect (LFD)-based BVS machines and broadcasting of SIM counts to each subscriber.
- Action against violating sale channels by CMOs, including the imposition of fines and the suspension and termination of sale channels;
- Action against Cellular Mobile Operators (CMOs) by the PTA. Show-cause notices were served to some mobile operators for the involvement of their sale channels in the issuance of gray SIMs.
- The cases of the issuance of gray SIMs are regularly shared with the Federal Investigation Agency (FIA).

(November 22, 2022) www.propakistani.pk

The work on the telecom industry infrastructure sharing framework by the Ministry of IT and Telecommunication has entered the final

stage. Sources in the MoITT told ProPakistani that the initial draft of the Telecom Industry Infrastructure Sharing Framework was shared with the stakeholders, on which the stakeholders have sent their recommendations to the MoITT. According to the sources, Tawal, Enfrashare, Sunwalk, Telenor, Jazz, Zong, PTCL, Wateen, Ufone, and other stakeholders shared their suggestions on active and passive infrastructure sharing with MoITT. The MoITT is finalizing the telecom industry infrastructure-sharing framework after incorporating these suggestions. According to the MoITT, the telecom industry infrastructure sharing framework will provide a mechanism for licensees and other stakeholders to share their telecom and other infrastructure facilities that would include space, electrical power, air conditioning, security, cable ducts, space on antenna and towers, etc. Infrastructure sharing promotes resource optimization by better utilization of assets, avoiding duplication of the network, saves time and cost in network and service rollouts. According to MoITT, the infrastructure sharing framework will open the huge potential for foreign direct investment and the inclusion of new companies in Pakistan. It will also facilitate cellular mobile operators to reduce operational costs to enhance sustainability. The framework once in place will open a new era of domestic and international investments in Pakistan and will increase job opportunities.

(November 30, 2022) www.propakistani.pk



Qatar

The Communications Regulatory Authority (CRA) approved about 29,000 requests between 2019-2022 that support the development of the telecom infrastructure in the State of Qatar. In addition to approving 1,068 requests to build new mobile sites, CRA also gave 21,215 approvals for non-objection requests to open roads for fixed infrastructure works through the Qatar Permit Road Opening (Q-PRO) system, in collaboration with relevant authorities in the State of Qatar. Furthermore, CRA handled 4,390 requests via the Qatar Online Design Review System (Q-DRS), and via the Duct Management System (DMS), CRA handled 2,116 requests related to the use of government telecom infrastructure. "The State of Qatar has a high-level telecom infrastructure, which contributes to the success of the FIFA World Cup Qatar 2022. This infrastructure is represented by a fiber-optic network that has achieved the goals of the comprehensive coverage strategy for all houses in Qatar, as well as mobile networks where the coverage rate of Fourth Generation technology (4G and 4G Advanced) reached around 100%, and the coverage rate of the Fifth Generation (5G) network reached around 96%," said Ali Al Suwaidi, Technical Affairs Department Director, CRA. To ensure that consumers in the State of Qatar have access to cutting-edge and top-notch telecom services, he continued, "CRA over the years ensured the development of the telecom infrastructure, including the mobile and fixed networks, at the highest levels by developing the necessary regulatory instruments and providing facilities for telecom Service Providers to develop their networks."

(December 11, 2022) www.thepeninsulaqatar.com

Qatar Communications Regulatory Authority (CRA) has selected a solution to monitor mobile operators' network quality supplied by network lifecycle automation expert Infovista. The aim is to use the solution during major upcoming sporting events in Qatar, where active and dynamic testing of live mobile networks in sports stadiums and key points of interest will help ensure that operators fulfil the obligations stipulated in their licenses when providing services to subscribers. By having a holistic view of the performance of all networks at key moments during events when usage spikes, Infovista says that the CRA will have an independent and true record of operator key performance indicators (KPIs) and be able to mandate service improvements where needed. The CRA will focus its monitoring and measurement on key locations including football stadiums, shopping malls, Doha Metro, and Hamad International Airport – all areas which will see a huge temporary influx of visitors and significant increases in demand for mobile voice and data services. Leveraging Infovista's fully autonomous network quality of service (QoS) monitoring solution, consisting of TEMS Sense and TEMS Director, the CRA will use network testing probes placed around key sites within these venues. In addition, it will dynamically test how the networks are responding to unscheduled spikes in data traffic as subscribers take to social media to share key moments with family and friends. TEMS Sense provides powerful network testing and measurement probes which the CRA can use to undertake active testing of all mobile networks. KPI data gathered will include

network quality, efficiency and throughput. TEMS Director acts as a 'fleet management' back-end, effectively managing the network of active probes, remotely pushing testing scripts to them to gather

data such as the success or failure rate on calls during moments of peak traffic.

(November 2, 2022) [developingtelecoms.com](https://www.developingtelecoms.com)



Saudi Arabia

The Communications, Space and Technology Commission (CST) announces the qualification of 4 applicants to participate in the upcoming Spectrum Auction in the 2100 MHz band for Non-Terrestrial Networks, which is set to be held on the 30th of November 2022. The auction has been designed to boost the NTN deployment, promote investments in the ICT sector, raise the spectrum usage efficiency in the Kingdom and emphasize the Kingdom's global leadership in enabling these technologies. CST announced the qualified applicants as follows: Saudi Telecom Company (STC), EchoStar, Omnispace, Salam in cooperation with Iridium, AST Space Mobile and Airbus. CST further clarified that the qualified applicants would be participating in the spectrum auction to acquire a total of (2x30) MHz bandwidth in the 2100 MHz band for the provision of Non-Terrestrial Network services, including Mobile Satellite Services (MSS), wireless connectivity on aircrafts (A2G), Internet of Things through satellites (Sat-IoT) and hybrid 5G connectivity (5G CGC). (November 20, 2022) www.cst.gov.sa

In collaboration with the International Institute of Electrical and Electronics Engineers (IEEE), the Communication, Space, and Technology Commission awarded the winners of the Competition on Non-Terrestrial Networks for B5G and 6G, which aims to support research and innovation in the future telecom networks field. The competition consisted of 28 submitted papers by more than 100

researchers and academics from 34 universities, representing 17 countries. The "Multi-Mode High Altitude Platform Station (HAPS) for Future Wireless Networks" ranked first, submitted by 4 researchers from Saudi Arabia and Canada, the "Toward Equitable 6G Access Service via Cloud-Enabled High-Altitude Platform Systems" ranked second, submitted by 4 researchers from Saudi Arabia, while the third place was for the "Uncrewed Aerial Vehicles Communications in Integrated Terrestrial and Non-Terrestrial Networks", submitted by 3 researchers from Spain and France. The papers contained a study and analysis of i) innovative ways to provide broadband telecom services in challenging areas by integrating terrestrial and non-terrestrial networks, ii) development mechanism for high altitude platforms technology (HAPS) to include multiple operational solutions and communication services in order to reduce costs and enhance service quality, iii) an analytical framework design to provide telecom services via HAPS by cloud computing to meet the needs of future telecom services and adopt it in the near future. Through this competition, the Commission aims to find innovative solutions that enable non-terrestrial networks, which are expected to be the foundation of the 6G future communication services, contribute in economy growth and diversity, and improve the services to bridge the digital divide and provide ICT services to all.

(November 8, 2022) www.cst.gov.sa



Sri Lanka

The Telecommunication Regulatory Commission of Sri Lanka (TRCSL) has informed the country's parliament that the necessary arrangements to start commercial activities related to 5G technology will begin in 2023. Speaking at the Ministerial Consultative Committee on Technology recently, officials from the regulatory agency confirmed that moves are afoot to allow mobile operators and ISPs alike to develop full-blown commercial services using fifth-generation technologies. Previously, in November 2021, the TRCSL revealed its intentions to issue a tranche of telecom licenses via auction, including 5G spectrum frequencies. In a speech that month, the country's then finance minister Basil Rajapaksa outlined a shift away from the usual process of awarding concessions to doing so via auction. Although details are patchy, the TRCSL plans to award a number of licenses for fixed voice, mobile, internet service provision and satellite broadcasting operations. Explaining the shift, Rajapaksa said the decision was made in consideration of the considerable CAPEX on telecoms services made via issuing the licenses and confirmed the auction

would include the sale of 5G-suitable frequencies. In the interim, the TRCSL has granted some mobile network operators (MNOs) rights to use spectrum in the 3.5GHz band (e.g. Dialog Axiata) for pre-commercial 5G services, while SLT-Mobitel activated its first 5G base station at One Galle Face in March 2020.

(December 5, 2022) www.commsupdate.com

Bharti Airtel Lanka CEO Ashish Chandra confirmed that a new firm, Lanka Portability, has been established to oversee the implementation of fixed and mobile number portability (FNP / MNP) in Sri Lanka. All of the country's domestic operators hold a stake in Lanka Portability, which is currently in the recruiting stage. Chandra noted that Sri Lanka does not currently have the local expertise required for the "big technical investment" of implementing number portability. Local outlets quoted him as saying: "It is a few million dollars which have to be put in and implementation itself takes about two to three quarters. I do not see it happening in the next two to three quarters, but work is

happening in this particular direction and hopefully next year we should be able to see it." In March 2021, the Telecommunications Regulatory Commission of Sri Lanka (TRCSL) announced that FNP and MNP would both be introduced in October that year. This target has evidently not been met despite receiving the required clearances in October 2021, although the TRCSL Director General Oshada Senanayake maintains that number portability will drive improvements in both voice and broadband quality by stoking competition in the market. (November 24, 2022) www.developingtelecoms.com

The government of Sri Lanka moved swiftly to dismiss speculation

in the press that it is holding, or has held, talks over the possible sale of Sri Lanka Telecom (SLT-Mobitel) to foreign investors, namely UK-based Lycamobile and the Adani Group. With trades unions threatening a series of walkouts across the islands against the decision, Justice Minister Wijeyadasa Rajapakshe said: 'There were no discussions on the sale of State Owned Enterprises [SOEs] at this week's Cabinet or anything concerning Sri Lanka Telecom.' The 2023 Budget proposes to restructure and divest several SOEs which include Sri Lanka Airlines, Sri Lanka Telecom, Colombo Hilton, Waters Edge and Sri Lanka Insurance Corporation (SLIC). (November 23, 2022) www.commsupdate.com



Turkey

The Deputy Minister of Transport and Infrastructure Dr. Ömer Fatih Sayan attended the Informatics Summit event organized with the theme "Technology Will Save the World". Sayan made important statements on informatics and technology. Speaking at the 22nd Informatics Summit, which was held for the 22nd time this year, with the participation of important names from the public and private sectors and academicians, Sayan stated that keeping up with digital developments and integrating technological developments into business processes is the most important condition for taking part in global competition. Deputy Minister Sayan said, "Today, more than 5 billion people in the world use the internet and it is estimated that there are more than 13 billion devices connected to the internet worldwide. It is estimated that by 2025 there will be

more than a hundred billion different communications worldwide, of which only 10% will be between people. It is expected that the number of devices connected to a network will reach trillions in the next 10-15 years," he said, giving important information about the future transformation of communication. Sayan, who stated that the need for high capacity and speed due to the increasing data traffic make new generation communication networks and fiber infrastructures mandatory, said, "As the Ministry and BTK, we are building, diversifying, and making the digital roads of our country more capable together with our stakeholders, and with new generation technologies, especially We give priority to fiber investments," he said. (November 24, 2022) www.btk.gov.tr



United Arab Emirates

The Telecommunications and Digital Government Regulatory Authority (TDRA) announced that every company or establishment registered in the UAE has automatically become part of Kashif initiative, which means showing the name and number of the calling party to the call recipient. This enables the call recipient to recognize the calling party and allows to decide whether to respond or not. TDRA has launched this initiative gradually, starting from mid-2021, in cooperation with the service providers, as part of enhancing customer satisfaction and happiness with telecommunications services in the UAE, and it is expected to have an impact in the future by reducing unwanted calls. TDRA indicated that it had enacted the regulations and executive procedures related to this feature, which comes as part of the development system aimed at enhancing the trust of customers in the telecom sector in general and in calls received from numbers of private sector companies in particular, and to reduce the dissatisfaction of telecom subscribers with anonymous calls. Today, the customer can identify the name of the calling party, whether the call is from a mobile or fixed number. TDRA confirmed that the launch of this feature came after reviewing the best international practices

and standards, holding consultations with service providers about the initiative, identifying the necessary regulatory tools to activate the feature, and making the necessary adjustments to the networks of service providers to activate the feature, in addition to conducting technical checks on mobile phones in coordination with manufacturers to ensure complete readiness. Commenting on this initiative, Eng. Saif Bin Ghelaita, Director of Technology Development Affairs at TDRA, said: "We all receive calls, often from unknown numbers or not registered in the recipient's phone. "Kashif" reveals the name of the calling party to the recipient along with its number. This initiative is part of TDRA's efforts to support the interests of the stakeholders, primarily the customers who will be able, thanks to this feature, to know the name of the calling party, and thus decide to answer the call or not. We are confident that this initiative will contribute to enhancing the happiness of telecom customers in the UAE, and we thank the service providers for their cooperation in this context." Bin Ghelaita added: "'Kashif' feature is unprecedented in the region. It is activated automatically for all calls, and it embodies best practices aimed at providing high-end communication services, taking into account the customers'

needs. We, at TDRA, will continue to implement an ambitious strategy to enhance services in this vital sector, which will reflect on the happiness of society, in implementation of the Government's directives in this regard." Initially, TDRA applied this feature to the numbers of the banking sector, to be expanded to the other sectors such as health, hospitality, education and others. This feature was applied to all numbers of private sector companies in 2022, and it includes fixed and mobile numbers registered in the name of private sector companies. TDRA confirmed that "Kashif" is considered the first line of the caller's identification, however, with the presence of this feature, customers must adhere to the directives of the authorities related to not disclosing personal information such as account number, password numbers, identification words, and others. (December 15, 2022) www.gulftoday.ae

The Telecommunications & Digital Government Regulatory Authority (TDRA), in cooperation with the ITU, held the ITU Workshop for Satellite Operators & Academia in the UAE on procedures and regulations of non-geostationary satellite systems. The three-day workshop held at TDRA's headquarters in Dubai was attended by 50 participants from 9 different entities: Al Yah Satellite Communication Company (Yahsat), Dubai Electricity and Water Authority (DEWA), Mohammed Bin Rashid Space Centre (MBRSC), National Space Science & Technology Center (NSSTC), Sharjah Academy of Astronomy, Space Sciences & Technology (SAASST), Khalifa University, Marshall Intech, Telecommunications Regulatory Authority of Bahrain and Bahrain's National Space Science Agency (NSSA). The workshop particularly targeted satellite operators, academia and other relevant organizations in the UAE, who already have or own space and satellite launch projects, requiring particular knowledge of ITU procedures and regulations related to satellite networks and systems. The workshop provided hands-on training with respect to ITU software and systems for the creation of various satellite network filings, advantages of joining the ITU as Sector Member or academic body, in addition to providing detailed information on space services and some other relevant topics. The workshop, presented by ITU experts, helped participants enhance their knowledge of regulatory procedures of satellite system and network filings, to develop their current and future space projects, which would contribute to capacity building and enhancing the UAE's position in the space sector. In his speech at the opening of the workshop, Eng. Tariq al-Awadhi, Executive Director Spectrum Affairs, welcomed the participants, and said: "This workshop is one of the events through which TDRA aims to raise awareness on the importance of the space sector, and introduce those interested to the ITU procedures and regulations adopted by all other state administrations. The popular and modern technology offered by satellite systems nowadays encourage us all to prepare and improve our capabilities in order for us to be proactive in this field, and co-develop such technologies to the benefit of our country in particular and the world in general." Mr. al-Awadhi thanked the ITU for their constant cooperation with TDRA in many events, adding: "We thank the ITU for participating in this event aimed at developing UAE's space sector, and invite all participants to strengthen their ties with the ITU staff and build meaningful relationships with all, in order to exchange knowledge and achieve fruitful cooperation." Workshop participants learned about the importance

of the academic sector in strengthening the capacity of the space sector, potentially leading to new space projects. Participants also benefited from ITU experts to learn about different aspects of the Radio Regulations and get hands-on experience in the ITU software. The UAE encourages various organizations to enter the space sector, as reflected in the development of initiatives and projects that brought about satellite launches for scientific, exploratory purposes and other space-based services.

(December 6, 2022) www.zawya.com

The Telecommunications and Digital Government Regulatory Authority (TDRA) announced the completion of the interconnection process between the UAE service providers, as part of the Internet Exchanges Union initiative "United IX". This initiative aims to link SmartHub IX platform supported by Etisalat by e&, and UAE-IX platform supported by Emirates Integrated Telecommunications Company du, to serve as an interconnection ecosystem at the national level. This partnership includes Etisalat's SmartHub IX, and du/datamena, with the support of TDRA. The connection of the two platforms allows the interconnection of all connected customers, regardless of the service provider, and is the first cooperation of its kind in the Middle East. Commenting on this step, H.E. Majed Sultan Al Mesmar, TDRA Director General, said: "This initiative is part of TDRA's efforts to develop the telecom sector infrastructure, enhance interconnection and integration to serve the objectives of attracting investments, providing the best experience for global companies such as emerging technology companies and service providers, in addition to enhancing speed of data transmission, and improving response time." H.E. Al Mesmar added: "We would like to thank everyone who contributed to United IX achievement, especially the Emirates Telecommunications Group Company PJSC, "Etisalat by e&", Emirates Integrated Telecommunications Company "du", and all other parties involved in this project. We appreciate their cooperation to overcome challenges and achieve this goal, which will make the UAE a hub for interconnection at the regional level. The parties worked together for a long time before reaching this result, and today we are reaping the fruits of this effort, which reflects the correctness of our bet on the ICT sector to create a prosperous future in light of the major digital transformations." In turn, H.E. Masood Mohamed Sharif Mahmood, CEO of Etisalat by e&, said: "This cooperation, the first of its kind in the Middle East, with the support of TDRA, will contribute to enhancing the capabilities of our SmartHub IX platform in line with the overall strategy of e& group to provide digital transformation technologies and innovative solutions to the telecom sector's customers in various fields. It is also in line with the vision of the UAE leadership in enhancing the country's leading position as a hub of ICT and data in the region, while meeting the diverse requirements of telecom infrastructure at the international level. For us, SmartHub IX is a key supporter of our digital infrastructure in the region, and we are committed to making it the partner of choice for carriers, cloud service providers, Internet providers, and companies looking for business-class data centers." H.E. Fahad Al Hassawi, CEO of Emirates Integrated Telecommunications Company (du), said: "seamless and reliable communication is an essential pillar for modern organizations that seek to keep pace with the requirements of the digital future. Therefore, providing enhanced

communication capabilities supported by an interconnection ecosystem that meets the requirements of organizations is the main driver of our new partnership with DE-CIX and Etisalat. As part of this partnership, we will harness the world-class capabilities of our datamena center to create and design hybrid environments for ICT systems. Our interconnection services and solutions that we will provide under this partnership will enhance the capabilities and quality of modern communication technologies, enabling our partners and all stakeholders to establish direct and secure communications and link their operations across multiple sites, as well as achieve savings in time and costs." In its 10th year, UAE-IX is the first carrier and data center for neutral internet exchange in the Middle East, connecting global networks, network operators and content providers in the GCC region, with 3 terabytes of connected customer capacity, United IX serves nearly 100 customers, including global corporations, carriers, cloud, content providers, emerging technology platforms, as well as banking and financial services companies. (November 14, 2022) www.zawya.com

The Telecommunications & Digital Government Regulatory Authority (TDRA) won the "Best Leadership Development of the Year" at the GCC level, as part of the GCC GOV HR Awards 2022. With this achievement, TDRA is the first federal entity to receive such award in human resource (talent) management. The GCC GOV HR Awards recognize the region's leading organizations, HR leaders and decision-makers for their innovative contributions, effective growth strategies, and their exemplary leadership role in raising the efficiency and performance of human resources. Commenting on this win, Mohammad Al Kitbi, Deputy Director General of the Support Services Sector, said: In keeping with the rapid economic developments and the modern culture in HR

capacity building, TDRA is moving ahead at an accelerated pace towards adopting the latest innovative practices in HR management, with a view to streamlining the HCM system using AI solutions and digital tools, thereby entrenching the notion of employee well-being and strengthening the foundations of the leadership and human development culture at TDRA. He added: Based on its vision, TDRA aims to be a leader in the ICT sector, and such leadership does not only come from infrastructure development and cutting-edge technology, but from the need to upscale functional cadre and create the right environment for innovation and doing the best at their jobs. TDRA has always been an ideal place to work, through its innovative initiatives in employee motivation, its distinctly positive workplace environment that promotes trust, dedication, belonging, team spirit, productivity, and through providing suggestions, initiatives and ideas to develop business and services. TDRA has, within the same Awards, nominated for multiple categories up against 200 entities, with winners being picked by a judging panel of experts on the categories: GCC GOV HR Team of the Year, Digital HR of the Year, Excellence in Talent Management of the Year, and Business Resilience of the Year. The nomination reflects TDRA's success in its human cadre investment, by following the latest global methods and practices in human resource development. The GCC GOV HR Awards is one of the region's most prestigious awards in human resources, which aims to highlight achievements of public sector organizations and individuals who have demonstrated exemplary leadership towards driving staff development in multiple areas like human capital management, corporate diversity and strategic planning. Encompassing 20 specialist categories, the GCC GOV HR Awards honor exemplary efforts of organizations and individuals towards HR excellence. (November 2, 2022) www.wam.ae/en

REGULATORY ACTIVITIES BEYOND THE SAMENA REGION



Angola

The Minister of Natural Resources, Oil & Gas, Diamantino Azevedo, has announced that the government is preparing to open an international public tender to find new shareholders for the country's mobile market leader Unitel, reports *Jornal de Negocios*. The minister told journalists that the move is aimed at protecting strategic telecoms sector assets and ensuring greater stability and efficiency for Unitel. Last month Angola finalized the nationalization of two 25% stakes in Unitel previously held by private companies Vidatel – owned

by Angolan billionaire Isabel dos Santos, daughter of former president Jose Eduardo dos Santos – and Geni, an investment vehicle of Leopoldino do Nascimento ('General Dino', a close associate of former president dos Santos). State oil company Sonangol owns the other 50% of Unitel, partly via its subsidiary Mercury Telecom (MSTelcom). Interpol recently issued an international arrest warrant against Isabel dos Santos at the request of the Attorney General of the Republic of Angola. (November 22, 2022) www.commsupdate.com



Armenia

The telecoms regulator the Public Services Regulatory Commission (PSRC) has reportedly approved a decision to hold a series of tenders for the rights to use the 700MHz, 800MHz and 1800MHz frequency bands. In creating a tender commission to oversee the process, the PSRC said the auction should lead to the deployment of 5G mobile broadband networks in Yerevan, Gyumri and Vanadzor, as well as increasing the proliferation of Internet of Things (IoT) technology and

improvements in terms of access to mobile broadband network coverage in indoor areas. Details are sketchy, but the government hopes the auctions will raise at least AMD3.8 billion (USD9 million) for state coffers from the licensing of 90MHz of radio frequencies through the tender. Further, successful licensees are forecast to need to spend between AMD25 billion and AMD35 billion to meet the obligations stipulated by the permits. (November 24, 2022) www.commsupdate.com



Australia

The Australian Competition and Consumer Commission (ACCC) has published a revised proposed variation to NBN Co's Special Access Undertaking (SAU), along with the material that the latter has already provided in support of its proposal. The ACCC states that the SAU is a 'key part' of the regulation of Australia's National Broadband Network (NBN), given it sets the rules for broadband providers to access the infrastructure over the coming decades, including minimum service standards and wholesale price controls. Previously, in July 2022 NBN Co "withdrew an earlier proposal" <https://www.commsupdate.com/articles/2022/07/28/nbn-co-withdraws-sau-variation-proposal> for a variation of its SAU, at which date the regulator noted that a consultation on those initial plans had identified 'a range of potential issues', while it highlighted the fact that submissions that consultation from the telecommunications industry were 'generally not supportive'. Now, in light of the updated variation proposals, the ACCC has said that, upon receipt of the remainder of the supporting material from the wholesale operator, it will confirm that it meets the ACCC's disclosure requirements. Meanwhile, it added that it intends to issue a public statement on the proposals when it publishes its consultation paper in relation to NBN Co's proposal, 'likely in early 2023'. ACCC Commissioner Anna Brakey was cited as saying of the matter: 'We've published NBN Co's revised

variation proposal today in the interest of transparency, so interested parties can begin scrutinizing it ahead of the remainder of NBN Co's supporting materials becoming available ... It is too early to comment on the substance of this revised proposal, but we will develop views to test with stakeholders when we release our consultation paper.' (November 30, 2022) www.commsupdate.com

The Australian Communications and Media Authority (ACMA) has launched a consultation on proposals to redraw the legislation governing the technical framework for several spectrum license bands that are currently due to expire on 1 April 2023. In its consultation on the matter, which runs until 2 December 2022, the ACMA said that it has formed a preliminary view that the legislative instruments – which relate to the 700MHz, 1800MHz, 2.5GHz and 2.5GHz 'mid-band gap' bands – are still operating 'effectively and efficiently' and as such 'continue to form a necessary and useful part of the regulatory framework'. To that end, the regulator has proposed remaking the technical framework instruments, while it has provided reasoning for any associated amendments in its consultation. According to the ACMA, it aims to make the new technical framework instruments in the first quarter of 2023, once it has considered the outcomes of its consultation process, while it has confirmed the new

technical framework instruments will revoke the current ones 'so as to avoid duplication'. Meanwhile, the ACMA also notes that spectrum licenses in some bands will need to be amended to incorporate any remade

technical framework instrument, saying that, where required, it will work with spectrum licensees to seek their agreement to make relevant amendments to their concessions. (November 4, 2022) www.commsupdate.com



Belgium

Telecoms regulator the Belgian Institute for Postal Services and Telecommunications (BIPT) has granted Orange Belgium and Proximus permission to reorganize their frequency allocations in the 900MHz band, before new user rights obtained in this summer's multi-band spectrum auction officially enter force on 1 January 2023. The regulator had extended the operators' existing 2G and 3G licenses, originally due to expire in March 2021, until the end of the year while it finalized details of the new permits. Following consultation with the country's regional regulatory authorities, the BIPT

has agreed that Orange can switch to the 905MHz-915MHz/950MHz-960MHz frequency range and Proximus 895MHz-905MHz/940MHz-950MHz with effect from 21 November 2022. During the transition period the amount of spectrum used by Orange and Proximus on each base transceiver station (BTS) must not exceed 2x11.6MHz and 2x12.5MHz, respectively. The regulator noted the shift frees up the 885MHz-890MHz/930MHz-935MHz range for use by new entrant Citymesh Mobile.

(November 17, 2022) www.commsupdate.com



Belize

A total of twelve regional 850MHz licenses held by Telefonica Brasil (Vivo) have been extended until 29 November 2028. As per the 11 November announcement in the Official Gazette, the Band A licenses comprise 2x11MHz of spectrum in the 824MHz-835MHz/869MHz-880MHz band, alongside 2x1.5MHz at 845MHz-846.5MHz/890MHz-891.5MHz. The concessions cover Sao Paulo, Minas Gerais, Bahia, Rio Grande do Sul, Goias, Tocantins, Roraima, Acre, Mato Grosso do Sul, Espirito Santo, Sergipe and Mato Grosso, although there are a handful of geographic restrictions in some regions. The licenses were scheduled to expire between December 2022 and September 2024.

(November 15, 2022) www.commsupdate.com

In a meeting chaired by Prime Minister John Briceno on 27 October, the Belizean cabinet gave its approval

for an amendment to Statutory Instrument No. 110, titled 'Telecommunications (Licensing Classification, Authorization and Fee Structure Amendment Regulations 2021)', to amend and clarify various aspects of the licensing process. The new regulations relate to the classification of licenses, services provided under various licenses, applicable license fees and a clarification of the services which can be provided under a class license. While specific details regarding the new licensing regime have not yet been made available, the government press office explained: 'These amendments would bring about much-needed clarity to the regulations, improve the administration by the Public Utilities Commission (PUC) of license holders and update the fees payable under the regulations to be in line with current industry costs.'

(November 3, 2022) www.commsupdate.com



Brazil

The National Telecommunications Agency (Agencia Nacional de Telecomunicacoes, Anatel) expects a total of 420 municipalities to be approved to utilize the 3.5GHz band for 5G services from 1 January 2023. TeleTime notes that this figure represents a notable drop from the initial projection of 480 towns and cities. Moises Moreira, head of the government's Group for the Implementation of Solutions for Interference Problems (Grupo de Acompanhamento da Implantacao das Solucoes para os Problemas de Interferencia, GAISPI),

cautioned that commercial launches in those locations will depend on the respective expansion strategies of national mobile operators Claro, Vivo and TIM Brasil. Since 6 October all 26 state capitals – and federal capital Brasilia – have been approved for Standalone (SA) 5G connectivity, with the cities receiving the green-light on a rolling basis. Claro, Vivo and TIM currently operate 5G services in all locations, thus fulfilling their licensing obligations.

(November 18, 2022) www.commsupdate.com



Canada

Federal Court proceedings have been instituted by the Australian Competition and Consumer Commission (ACCC) against Telstra, relating to allegations that the telco made 'false' or 'misleading' representations about

upload speeds to residential broadband customers signed up to its budget brand, Belong. In a press release regarding the matter, the regulator claimed that between October and November 2020 Telstra migrated

almost 9,000 customers who were on a Belong National Broadband Network (NBN) plan with a maximum download speed of 100Mbps and a maximum upload speed of 40Mbps, to a service with a maximum upload speed of 20Mbps. According to the ACCC, Telstra failed to notify customers of the reduction in the upload speed, and did not lower its charges, even though the cost charged by NBN Co to Telstra was AUD7 (USD5) a month less for the new service. ACCC Commissioner Liza Carver said of the matter: 'We allege 8,897 consumers who signed up to a Belong NBN plan between May 2017 and October 2020 were affected by this change and deprived of the opportunity to make an informed decision about their internet service.', Whilst Telstra acknowledged this failure in respect of approximately 2,500 customers between March and April 2021 and provided them with a one-off AUD90 credit, the ACCC notes that more than 6,300 subscribers are yet to be informed of the changes to their fixed broadband plan. As such, the ACCC is now seeking 'declarations, penalties, consumer redress, costs and other orders' with regards to the matter.

(December 6, 2022) www.commsupdate.com

The Canadian Radio-television and Telecommunications

Commission (CRTC) has launched its third call for applications for its Broadband Fund, aimed at projects to improve access to fixed and mobile broadband internet services across Canada. The third call focuses specifically on the following types of projects: telecommunications transport infrastructure projects; mobile infrastructure projects that provide or upgrade mobile connectivity along major roads; and 'projects that increase satellite transport capacity (operational costs) in satellite-dependent communities.' Applications are due by 18 April 2023. The CRTC's Broadband Fund will provide up to CAD750 million (USD554 million) over five years to support the digital economy. The CRTC launched its first call for Broadband Fund applications in June 2019, targeting the territories – i.e. the northern part of Canada consisting of Yukon, Northwest Territories and Nunavut – and satellite-dependent communities. Under that call, the regulator allocated funding to five projects. The watchdog launched the second call for Broadband Fund applications in November 2019, targeting eligible areas across all of Canada. To date, under the second call, the CRTC has allocated funding to 44 projects. In total, approximately CAD226.5 million has been dedicated to 49 projects in nine provinces and two territories so far. (December 1, 2022) www.commsupdate.com



China

China's telecom sector regulator the Ministry of Industry and Information Technology (MIIT) has awarded the nation's first private 5G network licence to Commercial Aircraft Corp of China (COMAC), China Daily writes. The award enables the state-owned aircraft manufacturer to use spectrum in the 5925MHz-6125MHz and 24.75GHz-25.15GHz ranges to operate its own private 5G networks. The decision is part of a move to promote the take up of 5G technology for industrial applications. Such industrial internet services have been a key focus of the 5G development programmes of the nation's telcos. China Mobile, for example, claimed in June this year that it had developed more than 300 5G showcases (industry-specific solutions) and had signed over 11,000 agreements for industrial 5G projects, including smart hospitals, smart factories and smart mines. China Telecom, meanwhile, reported that it was working on around 9,000 5G industry projects at the same date.

(November 30, 2022) www.commsupdate.com

The Ministry of Industry and Information Technology (MIIT) has approved plans for full-service provider

China Unicom to reform frequencies in the 900MHz band currently used for 2G, 3G and 4G services for its 5G systems. The operator noted that the propagation characteristics of the spectrum in question – 904MHz-915MHz/949MHz-960MHz – enable wide coverage, with low transmission loss, strong penetration and low network deployment costs. As such, the MIIT's approval for the use of the band for 5G will enable Unicom to rapidly promote 5G coverage in rural and remote areas with less investment, improving connectivity for citizens in those areas, 'expanding low-frequency 5G industry potential' and 'building a strong network base' for the provider's future development. China Unicom claimed a total of 201 million 5G package subscriptions at the end of September 2022. Notably, this figure only represents the number of Unicom customers with a tariff that permits them to access the 5G network and does not take into consideration network availability or the compatibility of the user's device.

(November 4, 2022) www.commsupdate.com



Colombia

The Communications Regulatory Commission (Comision de Regulacion de Comunicaciones, CRC) has ordered domestic mobile operators to implement a 37% reduction on their interconnection charges from 1 January. As per Resolution 7007 of 2022, from 1 January 2023 mobile termination rates (MTRs) will drop to COP8.81 (USD0.002) per minute, before decreasing

to COP5.56 from 1 January 2024 and COP3.51 from 1 January 2025. Regarding MVNOs, meanwhile, the CRC says it has 'modified the remuneration conditions in order to encourage free negotiation between companies, as well as the exploration of new business models. (December 20, 2022) www.commsupdate.com



Costa Rica

The Superintendency of Telecommunications (Superintendencia de Telecomunicaciones, Sutel) has urged the government to help it recover unused and underused spectrum in the 2.6GHz band, which it deems to be 'vital for the development of 5G in Costa Rica'. The demand follows high-level government intervention to help secure the 3.5GHz band for 5G use (see below). As before, state-backed utility firm/telco Grupo ICE (and its RACSA subsidiary) has been named as the culprit. Gilbert Camacho Mora, president of the Sutel Council, stated: 'The Executive Branch must continue with the immediate actions necessary to recover these resources, because they have the technical and legal criteria to move forward. A further delay in the arrival

of 5G in the country means a loss of competitiveness and loss of investment in the country, as well as a limitation to the benefits that users could receive from these technologies.' On 7 September president Rodrigo Chaves Robles confirmed that he has signed an agreement which will see state-backed utility firm/telco Grupo ICE return its unused 5G-suitable spectrum in the 3.5GHz band. The agreement covered frequencies in the 3400MHz-3500MHz and 3600MHz-3625MHz bands. In addition to the 2.6GHz and 3.5GHz bands, The Grupo ICE has previously been accused of under-use of spectrum in the 1400MHz and 26GHz bands.

(November 1, 2022) www.commsupdate.com



Croatia

The Croatian Regulatory Agency for Network Operations (Hrvatska regulatorna agencija za mrežne djelatnosti, HAKOM) has received five applications to participate in its forthcoming multi-band spectrum auction which is due to begin on 16 January. The sale includes 60MHz in the 800MHz band, 70MHz at 900MHz, 150MHz at 1800MHz, 120MHz in the 2100MHz range and 140MHz in the 2.6GHz band. There will also be up to 80MHz

available in the 3.5GHz band for regional (county level) operations, though this will be allocated via a separate auction process. Incumbent cellcos Hrvatski Telekom (HT), A1 and Telemach applied to take part in the 800MHz, 900MHz, 1800MHz, 2100MHz and 2600MHz auctions, while the regional 3.5GHz license sale will be contested by Digicom and Markoja.

(November 10, 2022) www.commsupdate.com



Cyprus

Turkcell has announced that its wholly-owned subsidiary Kuzey Kibris Turkcell (KKTCCell), which operates in the Turkish Republic of Northern Cyprus (TRNC), has participated in the Information Technologies and Communication Authority's (Bilgi Teknolojileri ve Haberleşme Kurumu, BTHK's) 4G/5G spectrum auction, held on 2 November 2022. KKTCCell bid USD16.462 million for a total of 247MHz of spectrum in the 700MHz, 800MHz, 900MHz, 1800MHz, 2100MHz, 2600MHz and 3600MHz bands, and will receive a 4G license with 18-year validity and a 5G license with 20-year validity.

The BTHK was initially planning to award 16 blocks of spectrum to the two existing mobile operators in the TRNC, KKTC Telsim and KKTCCell, in October (subsequently postponed due to an objection lodged with the Competition Board). The 4G authorizations will require successful bidders to deploy 4G technology with minimum downlink of 30Mbps ten months after license award. Regarding 5G, license holders will have three years to deploy 5G with minimum download speeds of 100Mbps to 60% of the population (95% within five years of license award). (November 4, 2022) www.commsupdate.com



El Salvador

The Electricity and Telecommunications Superintendency (Superintendencia General de Electricidad y Telecom, SIGET) has launched a public tender for mobile spectrum in the 1755MHz-1770MHz/2155MHz-2170MHz (Extended AWS) frequency range. The move follows a request from mobile network operator (MNO)

Telefonica Moviles El Salvador (Movistar). Interested parties have until 20 December to submit their applications for the 2x15MHz on offer, with the auction set to take place on 23 December. SIGET has set a minimum bid price of USD22.69 million for the frequencies.

(December 13, 2022) www.commsupdate.com



Estonia

The Consumer Protection and Technical Regulatory Authority (Tarbijakaitse ja Tehnilise Järelevalve Amet, TTJA) in Estonia has announced the winners of its 700MHz 5G spectrum auction. Incumbent cellcos Telia, Elisa and Tele2 all secured two 2x5MHz licenses. The auction began on 8 November, with each of the six available licenses carrying a starting price of EUR1 million (USD1.03 million). The process ended after three rounds of bidding, with Elisa offering EUR2.11 million, Telia agreeing to pay EUR2.01 million and Tele2 bidding

the minimum EUR2.00 million for two concessions. Licensees are obliged to cover 50% of every county within two years and 95% within four years, except for five counties where 700MHz coverage cannot be guaranteed due to interference from TV broadcasts in neighboring Russia. In these counties operators can meet the 95% target using other frequency bands. Earlier this year Elisa, Telia and Tele2 won 3.5GHz licenses. (November 15, 2022) www.commsupdate.com



Ethiopia

The Ministry of Finance (MoF) has issued an Expression of Interest (Eoi) for the partial privatization of incumbent telecoms provider Ethio Telecom, while also announcing the start of a consultation process regarding plans for a third licensee in the country. In a press release regarding the matter finance minister Ato Ahmed Shide stated that, following 'careful consideration' of current market conditions and a 'very stable outlook of the country', the Ethiopian government was now ready to engage with prospective bidders for a 40% stake in Ethio Telecom. Deloitte Consulting will reportedly act as the transaction advisor representing the government. At the same briefing as announcing plans to progress the partial privatization, Ato Balcha Reba, General Director of Ethiopian Communication Authority, confirmed that a stakeholder consultation process for the third

telecommunications operating license will run for a month, with any and all interested bidders able to join the consultation process. Meanwhile, Dr. Eyob Tekalign, State Minister at the Ministry of Finance, noted that the proposed sale of a stake in Ethio Telecom, coupled with the initiation of the stakeholder consultation process for the country's third telecommunication operating license, were both part of the government's telecom sector transformation plan, in which it aims to create a 'world class' telecom industry and enhance the country digital economy. In March this year the MoF announced that the partial privatization of the country's monopoly telecoms provider had been postponed 'given the recent developments and fast-moving macroeconomic changes both globally and from a country perspective'.

(November 17, 2022) www.commsupdate.com



France

France's independent telecoms regulator, the National Agency of Frequencies (Agence Nationale des Frequences, ANFR), has published its monthly update on the number of base transceivers stations (BTS) in the country, reporting that it had authorized a total of 37,412 5G sites as of 1 December, with 28,326 of these in operation. The agency said that almost all of the 5G sites have been authorized on existing cellular sites already used for 2G, 3G or 4G technologies. Free Mobile had the highest number of operational 5G sites at 1 December with 16,346, followed by Bouygues Telecom (9,184), SFR (7,881) and Orange (5,094). ANFR said that a total of 20,714 sites are authorized in the 700MHz band, of which 16,340 are already technically operational; Orange has one authorized site in the band, while Free has 20,713 (16,144 in operation). A total of 16,335 sites had been authorized in the 2100MHz band, with 10,289 of these in operation: Orange (716), SFR (8,758) and Bouygues (13,369). Meanwhile, 22,607 sites had been authorized in the 3.5GHz band, with 15,091 of these in operation: Orange (4,948), SFR (4,825), Bouygues (4,800) and Free (4,180).

(December 8, 2022) www.commsupdate.com

The independent telecoms regulator, National Agency of Frequencies (Agence Nationale des Frequences, ANFR), has published its monthly update on the number of base transceivers stations (BTS) in the country, reporting that it had authorized a total of 36,868 5G sites as of 1 November. The agency said that almost all of the 5G sites have been authorized on existing cellular sites, already used for 2G, 3G or 4G technologies. Free Mobile had the highest number of operational 5G sites at 1 November, with 16,152, followed by Bouygues Telecom (8,634), SFR (7,539) and Orange (4,850). ANFR said that a total of 20,407 sites are authorized in the 700MHz band, of which 16,144 are already technically operational; Orange has one authorized site in the band, while Free has 20,406 (16,144 in operation). A total of 15,940 sites had been authorized in the 2100MHz band, with 9,900 of these in operation: Orange (322), SFR (4,833) and Bouygues (12,965). Meanwhile, 21,742 sites had been authorized in the 3.5GHz band, with 14,333 of these in operation: Orange (4,693), SFR (4,483), Bouygues (4,483) and Free (4,025).

(November 7, 2022) www.commsupdate.com



French Guyana

Arcep has published a decision authorizing Local Public Company for the Digital Development of Guyana (SPLANG) to use frequencies in the 3420MHz-3460MHz band in French Guiana until 31 December 2026 for fixed connectivity services. Under the approval, SPLANG will

be authorized to provide fixed broadband services using the spectrum in the following isolated areas: Regina, Ouanary, Saul, Maripasoula, Camopi, Grand-Santi, Saint-Elie, Apatou and Papaichton.

(December 12, 2022) www.commsupdate.com



Ghana

Ghana's Minister of Communications and Digitalization, Ursula Owusu-Ekuful, has revealed that more than eight million unidentified SIM cards have now been deactivated by the country's telecoms operators, following the introduction of punitive measures intended to encourage customers to complete the registration process. As part of the re-registration campaign begun in October 2021, customers who had linked a SIM to their national ID card but had failed to complete the final biometric data capture stage by 30 November are denied access to voice, data, SMS and mobile money services. Having originally set a deadline of 31 July for registrations, slow progress and technical issues forced the authorities to extend this to the end of September and finally 30 November, while measures were implemented to facilitate the process and a series of penalties introduced to encourage subscribers to fully register their SIMs. MTN Ghana announced in late November that approximately 5.7 million SIMs on its network were eligible for deactivation. Customers

will have until the end of May 2023 to reactivate their accounts by completing the bio-capture process.

(December 9, 2022) www.commsupdate.com

The government, through the Ghana Investment Fund for Electronic Communications (GIFEC), has constructed 1,003 rural telephony sites under the Rural Telephony and Digital Inclusion Project, Graphic reports. Presenting the 2023 Budget Statement and Government Economic Policy to parliament, Minister of Finance Ken Ofori Atta noted the deployments had benefitted 1,353 rural communities, which now have access to mobile voice and data services. A further 700 new sites will be deployed next year as part of the project to provide voice and data services to 4,000 unserved and underserved rural communities, thereby facilitating social and economic growth. The Minister also highlighted the initiative would help extend aerial fiber coverage by 1,300km as backhaul to rural communities. (December 6, 2022) www.commsupdate.com



Greece

The first phase of Greece's tender process to find a universal service provider has ended with a single application, from Wind Hellas. Fixed and mobile operator Wind, which is part of United Group, has offered to provide universal services for a maximum annual compensation of EUR2.052 million (USD2.13 million). Applications for the second phase of the tender process are invited on 23 November. The universal service provider in Greece undertakes to supply broadband

internet access across the entire territory at minimum nominal download/upload speeds of 10Mbps/1Mbps, with guaranteed real-world download rates of at least 4Mbps. The maximum monthly price for the service is EUR27. Alongside internet access, the provider must also offer free unlimited local and long-distance fixed voice calls, or 1,500 minutes of talk time if connectivity is via a mobile network.

(November 17, 2022) www.commsupdate.com



Guinea

The Regulatory Authority for Post and Telecommunications (L'Autorité de Régulation des Postes et Télécommunications, ARPT) has unveiled its new strategic development plan for the period 2023-2025, which will serve as the main benchmark and roadmap for the body's annual planning and performance evaluation over the next three years. According to ARPT managing director Sekou Oumar Barry, the plan is based on four pillars, namely governance, rules and regulation, protection of consumers and citizens, and innovation. In addition, there are nine strategic objectives, 17 programmes, 43 projects, a detailed action plan as well as provisions for governance and performance monitoring. Establishing

the plan forms part of the ARPT's ambition to become 'the benchmark for collaborative governance and regulation' by 2025, the executive noted, adding: 'The general management, under the impetus of the new authorities, wants to ensure the organization makes a significant contribution to Guinea's economy.' The new strategic plan is the latest in a series of measures implemented by the regulator since the ruling military junta assumed power in September 2021. These include cuts to interconnection rates and call charges, penalties for service failings, and moves to relaunch the incumbent operator Guinee Telecom (formerly Sotelgui). (December 19, 2022) www.commsupdate.com



Haiti

Starlink – the Low Earth Orbit (LEO) satellite broadband provider backed by Elon Musk's SpaceX venture – has received a license to operate in Haiti. The company has been registered as Starlink Haiti and is permitted to 'operate freely in Haiti' using the Ku-band. Starlink

equipment can be purchased directly from the company's website, or obtained by an approved, authorized reseller. A press release issued by investment firm Resscop & Delaporte, which seemingly brokered the deal, states: 'The strongest assets of Haiti are the people. Today,

the people in rural areas of Haiti do not have readily available access to the internet. With Starlink's services, the people will be provided the opportunity to obtain reliable internet services ... The future development of Haiti is in the hands of those who are empowered to support its ecosystem.' Previously, in July this year National Council of Telecommunications (Conseil

National des Telecommunications, Conatel) authorized SpaceX to commence a two-year pilot program in Haiti. Earlier that month, meanwhile, neighboring Dominican Republic became the first Caribbean country to offer connectivity from Starlink on a commercial basis.

(November 29, 2022) www.commsupdate.com



Hong Kong

The Communications Authority (CA) has opened a consultation into the reassignment of spectrum licenses in the 850MHz and 2.3GHz bands. The proposals cover 20MHz at 850MHz which is currently split between two operators, plus 90MHz in the 2.3GHz range which is split between three firms. The 850MHz licenses expire in May 2026 while the 2.3GHz concessions expire in March 2027. The regulator is proposing reallocating the

concessions by way of a competitive auction process. A CA spokesperson said: 'Under the technology neutral approach, prospective spectrum assignees may make use of the spectrum acquired for the provision of 4G, 5G services, etc. to meet the future demand for innovative mobile services and applications.'

(November 18, 2022) www.commsupdate.com



Hungary

The National Media & Infocommunications Authority (Nemzeti Media- es Hirkozlesi Hatosag, NMHH) has released documentation for the planned auction of the currently unused 32GHz frequency band, with a consultation for market participants to be held on 22 November 2022. The regulator states that the purpose of the sale is to free up the 26GHz frequency band currently used for carrier network services and make it available for 5G services. The 'greenfield' 32GHz band

has been checked by the NMHH for interference – with measurements shown to be 'adequate' according to the regulator. A total of 672MHz of frequency usage rights split into 24 units will be available for purchase via an electronic auction. The 26GHz mmWave spectrum band has increasingly featured in the 5G license auction strategies of countries worldwide.

(November 11, 2022) www.commsupdate.com



India

India's Department of Telecommunications (DoT) is reportedly in favor of increasing the 5G spectrum allocation for state-backed telco Bharat Sanchar Nigam Limited (BSNL). According to the source the DoT committee has approved BSNL's proposal and the matter will now be discussed by an inter-ministerial panel before going to the cabinet for a final decision. The spectrum in the 600MHz (10MHz), 3300MHz (40MHz) and 26GHz (400GHz) bands had been reserved for BSNL's 5G services, but the operator requested that allotment be increased. The source claimed that the DoT has greenlit plans to award 10MHz in the 700MHz range and to increase the 3300MHz reservation to 70MHz. (December 16, 2022) The Economic Times

India's Department of Telecommunications (DoT) will seek input from the Telecom Regulatory Authority of India (TRAI) on the allocation of spectrum in the 95GHz to 3THz range for use in research and development of 6G technologies. According to the source, the airwaves

would be used for 'experimental purposes to develop products and solutions based on new technologies, particularly the sixth generation (6G)'. The initiative is intended to allow institutions, research organizations and industry players to obtain airwaves to conduct pre-standardization studies. By doing so India could take a more active role in standards setting, the official added, noting that this would also strengthen India's tech manufacturing industries. (November 11, 2022) The Economic Times

The Indian government has approved a deal between state-owned operator Bharat Sanchar Nigam Limited (BSNL) and Tata Consultancy Services (TCS) for the rollout of the former's 4G network. The officials aware of the details of the deal says that BSNL will purchase 100,000 sites, whilst TCS will be responsible for the deployment and maintenance of the sites for nine years. The purchase is estimated to be worth around INR268.2 billion (USD3.3 billion).

(November 10, 2022) The Economic Times



Ireland

Ireland's Commission for Communications Regulation (ComReg) has published the results of the main stage of its 'Multi Band Spectrum Award' sale process, to determine the winners and prices for a total of 470MHz of bandwidth being offered across four frequency bands – 700MHz, 2100MHz, 2300MHz and 2.6GHz. According to ComReg, the allocation of new spectrum is expected to 'significantly increase (by 46%) the spectrum available for fixed and mobile services, while facilitating operators in making long-term investment decisions essential for the widespread rollout of 5G services in Ireland'. Further, the spectrum sale will raise around EUR448 million (USD477 million) for the state, subject to the determination of legal proceedings. A total of four companies were confirmed to have successfully bid for new spectrum, with Vodafone Ireland emerging as the biggest spender, having bid EUR145.9 million for frequencies in the 700MHz (one 2x10MHz block), 2100MHz (two 2x20MHz blocks) and 2.6GHz (two lots of 2x35MHz FDD spectrum and two 1x30MHz TDD blocks) bands. For its part, Three Ireland also secured frequencies in three bands, having bid for EUR140.4 million for a 2x10MHz block in the 700MHz band, 2x20MHz blocks in the 2100MHz band, and two 2x35MHz FDD blocks in the 2.6GHz band. Meanwhile, eir laid claim to spectrum in the 700MHz (one 2x10MHz block), 2100MHz (one 2x5MHz block and one 2x20MHz block) and 2300MHz (two 1x60MHz block), after agreeing to pay a total of EUR140.2 million for these frequencies. Rounding out the winning bidders, Imagine Communications secured spectrum in the 2300MHz (two 1x40MHz blocks) and 2.6GHz (two 1x15 TDD blocks), with a bid of EUR21.5 million. In

terms of next steps, ComReg has confirmed it will now advance to the 'Assignment Stage' of the sale process, in which the specific frequency assignments for each band will be determined. ComReg will make a further announcement regarding this stage 'in due course'. However, the regulator did reiterate that, in line with an order from the Court of Appeal dated 8 November 2022, it will not notify the winning bidders of their entitlement to apply for licenses until a final determination has been made by the courts relating to an appeal lodged by Three Ireland against the spectrum sale back in July 2022. (December 15, 2022) www.commsupdate.com

Ireland's Commission for Communications Regulation (ComReg) has announced that the Court of Appeal has made an order varying a stay on the implementation of the country's planned multi-band spectrum auction, with this decision allowing the regulator to now progress the sale process. In a press release regarding the matter, ComReg revealed that the Court of Appeal made an order on 8 November altering a stay which had previously been granted by the country's High Court back in July 2022, following an appeal lodged against the spectrum sale by local cellco Three Ireland. Now, according to the Court of Appeal's ruling, ComReg will be permitted to proceed to the 'Main Stage' of the multi-band spectrum award (i.e. the auction itself), although the regulator will notably be prevented from 'notifying the winning bidders of their entitlement to apply for licenses', pending a final determination regarding the matter from the courts. As a result of the Court of Appeals' order, ComReg has confirmed it is now progressing the main stage of its spectrum sale process. (November 10, 2022) www.commsupdate.com



Isle of Man

The telecom watchdog the Communications and Utilities Regulatory Authority (CURA) has announced the launch of a first stage competition assessment relating to the British Crown Dependency's retail mobile markets. According to the regulator the move is the first step in 'a more comprehensive review of the competitive dynamics in the Isle of Man telecoms markets, in line with best practice and the Authority's statutory obligations. In announcing the development, the CURA said that as part of its routine monitoring it had noted a number of areas for potential concern within some markets, particularly certain retail markets. With the stated purpose of its market assessment being 'to gather evidence on whether there is likely to be sufficient competition within the Isle of Man's

mobile markets', the regulator has said that should it uncover evidence which suggests that there is cause for concern with regards to the competitive nature of the mobile market, it would then commence a 'Market Review' under Part 5 Division 4 of the Communications Act 2021 and devise appropriate remedies in order to encourage effective competition in those markets. A previous mobile market review by the Isle of Man authorities was conducted in 2019, although following this no operator was designated as holding significant market power (SMP) in the retail mobile market, while the market itself was not found to be susceptible to ex-ante regulation. As such, there are currently no regulatory remedies in place.

(November 17, 2022) www.commsupdate.com



Italy

Italian state lender Cassa Depositi e Prestiti (CDP) is not now expected to make a bid to acquire the fixed network assets of Telecom Italia (TIM), with the government now looking at new options for the telco's future. Italy's previous administration had wanted to push through the spin-off and sale of TIM's fixed infrastructure, with this then merged with CDP-backed wholesale operator Open Fiber to create a single national network under government control. CDP had been due to submit a non-binding offer for the TIM assets by today (30 November). Reuters cites a statement from Industry Minister Adolfo Urso and cabinet undersecretary Alessio Butti which

says the new government under Giorgia Meloni aims to set up a working committee to find the 'best viable market solutions' for TIM by the end of the year, 'to maximize the interests of the country, of the companies involved and of their shareholders and stakeholders'. Butti favors a plan where CDP takes full control of TIM and then sells off its service business and subsidiary in Brazil. The remaining network operations would be merged with Open Fiber. CDP owns 60% of Open Fiber and almost 10% of TIM. TIM's largest investor is Vivendi of France with a 24% interest.

(November 30, 2022) www.commsupdate.com



Japan

Japan's new fourth mobile operator Rakuten Mobile has received a slap on the wrist from the Japanese government which, issuing Administrative Guidance to the company, warned it not to repeat the 'massive disruptions' of its voice and data services that affected many of its customers in September this year. The Ministry of Internal Affairs and Communications (MIC) noted that the outages affected some 110,000 people in terms of voice call service failures and 1.3 million

people were hit by the data transmission disruption, caused by a software malfunction in equipment at a data center. The MIC has since inspected the data center to ensure that corrective measures are being put in place, with Rakuten Mobile President Shunsuke Yazawa saying: 'We solemnly accept the instruction and will thoroughly follow it on a companywide basis.'

(December 12, 2022) www.commsupdate.com



Kyrgyzstan

The Telecommunications Committee of Kazakhstan's Ministry of Digital Development, Innovation & Aerospace Industry (MDAI) has placed two 1x100MHz blocks of 5G mobile frequency spectrum in the bands 3600MHz-3700MHz and 3700MHz-3800MHz on the electronic trading platform E-auction.gosreestr.kz for an auction beginning on 20 December 2022. As reported by Kazakh news site Profit.kz, the starting bid price for one block

is KZT1.761 billion (USD7.34 million), while qualified bidders must operate existing telecoms networks covering at least six regions. Kazakhstan's mobile network operators – Kcell and Tele2-Altel (both part of the Kazakhtelecom group) and private sector rival KaR-Tel (Beeline) – have all launched pilot 5G network zones but are awaiting commercial 5G licensing.

(November 30, 2022) www.commsupdate.com



Lesotho

South Africa's Vodacom Group has revealed that the Lesotho High Court has issued an order setting aside a number of decisions of the Lesotho Communications Authority (LCA), following an amicable and negotiated settlement agreement between the parties. This includes a decision by the LCA to revoke the operating license of Vodacom Lesotho. In the same order, which was issued on 1 November, Vodacom Lesotho was directed to make a payment of ZAR4 million (USD231,000) to the LCA. The dispute between the LCA and Vodacom dates back to 2019, when the regulator accused Vodacom of a number of infringements, including failure to pay regulatory fees, failure to meet Universal Access Fund

(UAF) obligations and failure to appoint an independent external auditor, as required by the terms of its operating license and the Lesotho Companies Act, 2011. While some of these issues were resolved in early 2020, in September that year the LCA fined Vodacom a total of LSL134 million (USD7.7 million), before the following month saying it was revoking the operator's license for failure to pay the penalty. Vodacom lodged an application in the High Court to have both determinations reviewed and set aside, and the court subsequently issued an interim order to prevent the license revocation and the enforcement of the fine.

(November 15, 2022) www.commsupdate.com



Malaysia

Anwar Ibrahim, Malaysia's new Prime Minister, has announced that his administration will launch a review of the country's state-owned 5G network strategy. With Digital Nasional Berhad (DNB) having been set up under the previous government to oversee the rollout of the country's 5G infrastructure, the new PM confirmed that the matter would be reassessed amid concerns there had been 'no proper tender process' in the appointing of Ericsson as DNB's network development partner. 'It needs to be reviewed because it was not done in a transparent manner,' Anwar said. In response to the development, DNB said it would cooperate with the government's review and was keen to stress that the award of the contract to Ericsson had been conducted transparently. A statement issued by the wholesale operator read: 'DNB hopes the review... will clear the air and enable full execution and implementation of

the 5G rollout for the benefit of the nation.' In related news, DNB and Ericsson claim to have achieved a world record distance for gigabit speeds over the former's 5G network. A test conducted using 28GHz millimeter wave (mmWave) spectrum was reported to have achieved a peak throughput of 1Gbps at a record distance of 11.18km from a radio antenna in Butterworth, Penang to a point off the island. Only last week DNB confirmed that its 5G network now covers 'approximately 38% of populated areas nationwide', including key industrial areas across the Klang Valley, Penang and Johor. Other coverage areas include parts of Negeri Sembilan, Malacca, Perak, Kelantan, as well as Sabah and Sarawak. Looking ahead, DNB has claimed it is on track to extend its network footprint to cover 80% of the Malaysian population by 2024.

(December 6, 2022) www.reuters.com



Montenegro

Telecoms watchdog the Agency for Electronic Communications and Postal Services (EKIP) has announced that three operators – Crnogorski Telekom, MTEL and One Montenegro – have qualified to participate in the auction to allocate spectrum in the 700MHz (694MHz-790MHz), 3.6GHz (3400MHz-3800MHz) and 26GHz (24.25GHz-27.5GHz) bands for public mobile networks, which will be staged between 19 and 23 December. EKIP aims to award a total of

1,460MHz of spectrum in the three bands as follows: seven blocks of 2x5MHz spectrum with an opening price of EUR690,000 (USD727,191) and two lots of unpaired 5MHz frequencies in the 700MHz band (EUR70,000); 38 blocks of 10MHz spectrum in the 3.6GHz band (EUR95,000); and five lots of 200MHz spectrum in the 26GHz band (EUR100,000). All frequencies will be valid for 15 years from the date of approval.

(December 5, 2022) www.commsupdate.com



Myanmar

The Ministry of Transport and Communications (MOTC) has issued a notification to inform users of a planned SIM checking scheme. The ministry advised mobile users to ensure that the name registered to their SIM was correct, as this information would be

checked against the National Database and SIMs with discrepancies would be disconnected. Users have until 31 January 2023 to make any necessary corrections.

(December 6, 2022) www.commsupdate.com



Namibia

The Chief Executive of the Communications Regulatory Authority of Namibia (CRAN), Emilia Nghikembua, has called for more private sector investment to improve telecom network coverage, particularly 4G, in the country. In a statement following the launch of the watchdog's Telecommunications Market Report for 2021, which revealed that Namibia's 4G population coverage stood at 85% last year, the executive stressed improved connectivity is particularly necessary in underserved communities such as the Kunene, Oshikoto, Kavango West, Zambezi, Omaheke, Otjozondjupa and Hardap regions. According to the report, only seven of the country's 14 regions were covered by 4G networks, while the Kunene, Kavango West and Omaheke regions had less than 50% 4G population coverage. It also

highlighted that the country continues to suffer from a lack of digital skills and high prices for mobile data and smartphones, as evidenced by the fact that only 66% of the 2.9 million mobile subscriptions at end-2021 accessed mobile data services – up from 61% in 2016. To address these concerns, the CRAN plans to implement measures to promote technological innovation and improve quality of service, including the release of additional spectrum to ensure costs for end users are affordable. Nghikembua revealed the regulator is preparing to issue 5G spectrum in March 2023, which will be accompanied by a consumer awareness campaign to address misconceptions and misinformation about the technology.

(December 14, 2022) www.commsupdate.com



The Netherlands

The Netherlands' Telecommunications Agency (Agentschap Telecom [AT], soon to be renamed the National Inspectorate for Digital Infrastructure [Rijksinspectie Digitale Infrastructuur]) is launching a 'Dynamic Spectrum Management & Sharing' (DSMS) pilot in the 3.8GHz-4.2GHz frequency band with the Dutch Trade Association of Major Telecom Users (BTG), Schiphol Airport and satellite communications operator Speedcast in Biddinghuizen. Nokia and the Finnish research institute VTT are also involved. The pilot was commissioned by the Ministry of Economic Affairs & Climate Policy. AT notes that the DSMS pilot will explore new methods that can allow local private (industrial) networks to exist in the 3.8GHz-4.2GHz band, without interference of the reception by satellite ground stations. With the test results, the agency aims to create possibilities for new methods in European regulation for frequency allocation. Testing will take place with two users in the 3.8GHz-4.2GHz band: a local 5G network at Schiphol Airport and the satellite ground station in Biddinghuizen. Under certain atmospheric conditions, a local network can cause incidental interference on the reception of satellite signals even in case of low power from a large distance. Therefore, a large protection zone applies around satellite ground stations. With the DSMS pilot, the parties involved want

to demonstrate that with new technology, such a large zone is not necessary. The first results of the pilot are expected by mid-2023. (December 12, 2022) www.commsupdate.com

On 1 January 2023 the Netherlands' Telecommunications Agency (Agentschap Telecom – AT) will be renamed the National Inspectorate for Digital Infrastructure (Rijksinspectie Digitale Infrastructuur) to reflect a broadening of its scope. As reported by Dutch news site AGConnect, the government agency will retain its current responsibilities but will widen its remit to 'invest in the digital security of the Netherlands'. The Dutch telecoms operators are chiefly regulated by the autonomous Authority for Consumers & Markets (ACM) while AT is responsible for the management of radio frequency spectrum, operating under telecoms policymaker the Ministry of Economic Affairs & Climate Policy (MEACP) and including a subordinate division, the Antenna Bureau. AT Director Angeline van Dijk told AGConnect: 'In the past we only had to deal with the [MEACP], but now we are also often at the table with the Interior and Security and Justice [Ministries]. The field of work is therefore broadening, especially with the deepening of cybersecurity.' The name change and renewed focus will be officially presented to the MEACP on 7 November. (November 4, 2022) www.commsupdate.com



New Zealand

The government has announced the successful completion of the second phase of the Ultra-Fast Broadband (UFB) network, concluding an eleven-year national program which has provided fiber connectivity to 1.8 million homes across 412 towns and cities, equivalent to 87% of the country's population. The project, a partnership between Crown Infrastructure Partners (CIP) and wholesale fixed line providers Chorus, Enable, Northpower and Tuatahi First Fiber, was completed on time and on budget. The first stage of the UFB project was completed in November 2019, at which point fiber broadband was available to 79% of New Zealanders, while an extension to the program announced in January 2017 expanded the footprint to smaller and more remote towns. The four fiber companies and their contractors have spent more than 45 million work hours installing cabling over the past decade, with Chorus alone deploying more than 98,000km of fiber in the two stages. 'Today's milestone wouldn't have been possible without a successful public and private partnership. I commend all of those companies who have helped deploy UFB up and down the country over the past twelve years,' said Minister for the Digital Economy and Communications David Clark. 'Taken alongside other government connectivity programmes such as the Rural Broadband Initiative and Mobile Blackspot Fund, we are firmly on track for ensuring 99.8% of the population has access to improved broadband by the end of 2023,' he added.

(December 16, 2022) www.commsupdate.com

Some of New Zealand's most remote communities will receive broadband for the first time thanks to a new government-led initiative. The Remote Users Scheme (RUS) will equip as many remote households as possible with the connectivity infrastructure needed to access broadband services, Minister for the Digital Economy and Communications, David Clark announced. 'Whilst these locations might be off the grid, it doesn't mean they can't be connected to it in some way,' the Minister said, noting NZD15 million (USD9.2 million) was allocated to the scheme in the 2022 budget as part of the broader NZD60 million rural connectivity package announced earlier in the year. Crown Infrastructure Partners (CIP) will administer the RUS and will soon be calling for applications from potentially eligible households and communities. Through the initiative, eligible households and communities in the country's most remote areas – where broadband is not currently available and there is only access to voice calling and text services – will be able to apply for support. The RUS will also be available in rural areas with poor internet coverage. The first phase of the scheme aims to provide a broadband internet service to an area by extending existing networks. Those still without coverage after this has been done may be eligible to receive a one-off grant of up to NZD2,000 towards set up and installation costs of a suitable broadband solution. It is expected that new broadband connectivity infrastructure for the eligible areas and households can begin being built in mid-2023. (November 18, 2022) www.commsupdate.com



Nicaragua

The Nicaraguan Institute for Telecommunications and Posts (Instituto Nicaraguense de Telecomunicaciones y Correos, Telcor) has outlined plans to utilize the 3.5GHz band to support the country's future 5G ambitions. As per Administrative Agreement No. 002-2022, which appeared in the country's Official Gazette on 24 November, the watchdog has reserved the 3300MHz-3400MHz, 3400MHz-3600MHz and 3600MHz-3700MHz bands for the provision of 5G services. Telcor has observed that the currently awarded spectrum

holdings in the 3.5GHz band – which TeleGeography believes comprises a 50MHz block held by Claro – are 'not technically adequate to satisfy the bandwidth specifications' of 5G, meaning a reorganization will take place before any new concessions are distributed. The introduction of 5G forms part of the government's Plan Nacional de Lucha Contra la Pobreza y para el Desarrollo Humano 2022-2026 (National Plan to Fight Poverty and for Human Development 2022-2026).

(December 4, 2022) www.commsupdate.com



Nigeria

The Nigerian Communications Commission (NCC) has announced that Airtel Nigeria emerged as the sole bidder in the upcoming 5G auction and therefore will proceed to the 'assignment stage' in line with the published Information Memorandum guiding the licensing process. According to the regulator, by the close of business on 5 December only two companies had expressed interest in participating in 3.5GHz spectrum auction, namely Airtel and Standard Network & Connections Limited (Standard Network). However, only Airtel paid the Intention to Bid Deposit (IBD), while Standard Network requested the deadline be extended by twelve working days, which the NCC ruled was not acceptable in view of the auction timetable. Consequently, there shall be no further bidding and the NCC will proceed to the assignment stage to allocate the spectrum to Airtel. The NCC had planned to auction off the remaining two lots of 100MHz TDD spectrum in the 3.5GHz band on 19 December, ranging from 3400MHz-3500MHz and 3600MHz-3700MHz. Each lot had a reserve price of USD273.6 million, with the nationwide spectrum licenses valid for ten years. Winning bidders are required to launch commercial 5G services within twelve months of the effective date of the license, and coverage should reach at least two states in each of the country's six geo-political zones within two years.

(December 8, 2022) www.commsupdate.com

The Nigerian Communications Commission (NCC) is set to engage telecommunications stakeholders on the final document for its planned auction of two more lots in the 3.5GHz Spectrum for the deployment of the fifth-generation (5G) services. The process for the auction of the proposed lots of frequencies for 5G services commenced on October 21, 2022 with the publication of the Draft Information Memorandum on the Commission's website. In an earlier statement and subsequent advertisements, the Commission advised stakeholders to study the Information Memorandum for comments and questions. The stakeholder interactive session will

take place at the Marriot Hotel, Ikeja, Lagos, by 9.00 am prompt on November 15, 2022. The engagement session will feature comments and submissions made by the different stakeholders on the Draft Information Memorandum. The regulator had earlier announced the plan to license additional lots in the 3.5 GHz spectrum band for the deployment of 5G Global System of Mobile communication. The auction which is set to take place in December 2022, would see the Commission and the stakeholders discuss and provide more insight into the Draft Information Memorandum (IM) that will guide the process. The outcome of the submission will be considered by the Commission in publishing the Information Memorandum for the auction.

(November 14, 2022) www.icirigeria.org

The Nigerian Communications Commission (NCC) has announced the inauguration of an industry-wide committee to facilitate the deployment of broadband infrastructure under the National Communications Backbone (NCB) project. Chaired by the NCC's Director of Digital Economy Augustine Nwaulune, the National Broadband Infrastructure Joint Committee (NBIJC) is also composed of representatives from mobile network operators, infrastructure companies and tower companies. It is responsible for supporting the drive towards the realization of the NCB targets, as outlined in the Nigerian National Broadband Plan (NNBP) 2020-2025. These include the deployment of 120,000km of fiber across the country, increasing broadband penetration to 70% by 2025, and connecting 60% of communication towers with fiber. In addition, the committee is mandated to initiate engagements with identified sources of funding, including the Nigeria Sovereign Investment Authority (NSIA), the Infrastructure Corporation of Nigeria (InfraCorp), the African Development Bank (AfDB) and the Central Bank of Nigeria (CBN).

(November 8, 2022) www.commsupdate.com



Peru

The Peruvian Ministry of Transport and Communications (MTC) has announced plans to begin reassigning spectrum in the 800MHz band in order to allow the deployment of 4G and rural services. The band in question has so far been used for the deployment of trunked networks, technology inherited from the operator Entel which is described as currently obsolete. MTC hopes that the reassignment process will allow these frequency bands to be better used, suggesting that the reassignment of the 800MHz band (806 – 824MHz 851 – 869MHz) could benefit more Peruvians, not only through the deployment of modern services based on mobile technologies such as 4G but through the development of smart cities. There is 4G coverage

already in place from a number of mobile operators. However, the 800MHz band is at the lower frequency end of mobile-friendly spectrum, which means that such signals are attractive for delivering wide geographic coverage – notably in rural areas. Thus, the hope is also that these measures will contribute to closing the digital divide, especially in rural areas. In fact, MTC argues that the investment commitments obtained from the process could be allocated to the implementation of telecommunications infrastructure in underserved rural and remote areas of the country. It's not clear, however, when this process will begin or, for that matter, how or whether an auction process will be involved.

(November 27, 2022) www.developingtelecoms.com



Poland

The Office of Electronic Communications (Urząd Komunikacji Elektronicznej, UKE) in Poland is launching a consultation process on 20 December ahead of the planned award of 5G licenses in the 3.5GHz band (3480MHz-3800MHz) next year. The allocation process has been delayed while the government updates the Electronic Communication Law and the Act on the National Cybersecurity System (KSC). In October 2022 industry body Digital Poland (Cyfrowa Polska) wrote to the government to request that 3.5GHz C-band spectrum be made available for 5G services 'as soon as possible', saying that the prompt allocation of licenses was 'necessary and urgent'. Among EU countries, only Poland and the Netherlands have failed to award 3.5GHz concessions to support 5G. UKE had previously opened an auction for four 3.5GHz licenses in March 2020, with each offering 80MHz of spectrum, but the process was cancelled due to the COVID-19 outbreak.

(December 14, 2022) www.commsupdate.com

Cable operator Vectra is facing fines for failing to meet the conditions imposed by the country's

competition regulator when approving the takeover of rival Multimedia Polska. In January 2020 the Office of Competition and Consumer Protection (Urząd Ochrony Konkurencji i Konsumentów, UOKiK) gave the green light to the merger of Vectra and Multimedia if Vectra agreed to sell networks in eight cities and offer customers in a further 13 markets the option of changing provider without costs. The watchdog now says that the cableco has sold networks in just three cities and it faces a fine of up to EUR10,000 (USD10,539) per day. Telko.in has published a response from Vectra which states: 'To date, Vectra has met the vast majority of the conditions imposed by [UOKiK], and the networks not yet sold represent only an insignificant percentage of Multimedia Polska's assets.' It says that it has increased competition in the affected markets by deploying fiber-to-the-home (FTTH) infrastructure and allowing rival operator Play to offer services over its networks. It goes on to add: 'Our actions directly address issues regarding the possibility for customers to use the services of more than one supplier.'

(December 5, 2022) www.commsupdate.com



Romania

Telecoms watchdog the National Authority for Management & Regulation in Communications (ANCOM) has announced that the country's mobile network operators (MNOs) have fulfilled an obligation to provide voice services to at least 98% of the country's population. According to field measurements conducted between May and October of this year, RCS&RDS (DIGI) covered 98.8% of the population with mobile voice services, Orange Romania 98.5%, Telekom Romania Mobile Communications 98.5% and Vodafone Romania 98.4%. Telekom Romania was fined RON700,000 (USD149,250) in January 2021 for non-fulfilment of its spectrum license obligation to achieve the required coverage by April 2017, after an earlier monitoring survey found 97.25% of the population were within its voice services footprint. (December 8, 2022) www.commsupdate.com

Telecoms watchdog the National Authority for Management & Regulation in Communications (ANCOM) has announced the completion of its 5G multi-band spectrum auction, which saw the three bidders – Orange Romania, Vodafone Romania and RCS&RDS – agree to pay a total of EUR432.6 million (USD448.3 million) for 420MHz of frequencies in the 700MHz, 1500MHz, 2600MHz and 3400MHz-3800MHz bands, equivalent to 75.6% of the spectrum on offer. The country's fourth mobile network operator (MNO), Telekom Romania Mobile Communications, opted to sit out the tender process. Orange Romania was the highest bidder, paying EUR264.61 million for two blocks of 2x5MHz FDD spectrum in the 700MHz band, all eight blocks of 5MHz in the 1500MHz band, and 16 lots of 10MHz in the 3400MHz-3800MHz band. For its part, Vodafone Romania bid a

total of EUR122.5 million for 2x5MHz of 700MHz FDD spectrum and ten blocks of 10MHz in the 3400MHz-3800MHz band, while RCS&RDS was awarded four blocks of 2x5MHz of 2600MHz FDD spectrum and five lots of 10MHz in the 3400MHz-3800MHz band, paying a total of EUR45.5 million. User rights for spectrum in the 700MHz and 1500MHz bands will be valid for 25 years from 1 January 2023, the 3400MHz-3800MHz frequencies for 22 years starting from 1 January 2026, while rights in the 2600MHz band will be valid for the period 1 January 2023 until 5 April 2029. In terms of coverage

commitments, the winning bidders will be required to provide mobile broadband services to at least 70% of the country's population, most urban areas, highways, international airports and modernized railways, as well as 240 localities identified as having no or poor mobile coverage. The EUR432.61 million raised by the auction will be paid in instalments, with the first payment totaling EUR119 million scheduled for 8 December and the final instalment of EUR80.01 million due on 17 November 2029.

(November 16, 2022) www.commsupdate.com



Russia

The State Commission for Radio Frequencies (SCRF) reportedly plans to formally allocate mobile frequencies to Russian-backed network operators in occupied territories of Ukraine, namely parts of the Zaporozhye and Kherson regions currently under Russian military occupation and the self-proclaimed People's Republics of Donetsk and Luhansk (DPR and LPR). According to an RBC article, the companies to be licensed are named as MirTelecom, Mobile Communications Systems (Luhansk), K-Telecom (an established Crimean network operator using the WIN Mobile brand) and separatist-owned DPR operator Phoenix (Feniks). GSM/UMTS/LTE

spectrum is reportedly set to be offered in the 700MHz, 800MHz, 900MHz, 1800MHz, 2100MHz and 2600MHz bands. The LPR separatist authorities transferred the mobile operations of Lugansk Communications (Lugacom) – launched in 2015 – to the newly established Mobile Communications Systems ('MKS') on 1 July 2022 – claiming 'one million active subscribers' at that date (unconfirmed). Lugacom continues to operate as a wholesale internet network provider. LPR and DPR networks have used the Russian numbering prefix '7' since 1 May for mobile and 1 August for fixed telephony.

(December 13, 2022) TelecomDaily



Senegal

The Regulation Authority for Telecommunications and Posts (L'Autorite de Regulation des Telecommunications et des Postes, ARTP) is seeking stakeholders' views on the future deployment of 5G services in the country, ahead of the planned publication of its 5G roadmap in March next year. The consultation, which will end on 3

January 2023, is intended to gather feedback on a range of issues including the most suitable frequency bands, the amount of spectrum to be allocated, license fees and validity, potential rollout schedules, and coverage obligations.

(December 16, 2022) www.commsupdate.com



Somalia

There was a recent announcement of what Somalian regulator the National Communications Authority (NCA) calls an important milestone: an interconnection agreement with Somali telecommunication companies that will allow customers of the various operators in the country to call each other seamlessly across different networks. The agreement was said to be the result of a series of discussions and consultations between the relevant parties that worked out all the fundamental issues necessary for the signing of the deal, including the tricky (as Kenyan operators may agree) mobile termination rate (MTR) issue. The interconnection agreement comes into force on 10 January 2023; the interconnection process will be completed by February of the same year. Mustafa Yasin Sheikh, General Manager of the National Communications Authority, said of the agreement: "In addition to the interconnection agreement being a requirement and a right for the customer, it is also an important benchmark for the growth of the telecommunications

market and the investment in technology and innovation, and I hope that this agreement will put an end to discussions that have lasted since the inception of telecom companies in the country." The National Communications Authority (NCA) is the regulatory body for the communications sector in Somalia. NCA was established through the Communications Act of 2017. Its mandate is to regulate the communications sector including telecommunications, internet, broadcasting, information, communications technology and e-commerce services.

(December 12, 2022) www.developingtelecoms.com

The National Communications Authority (NCA) has begun the process of awarding official mobile spectrum licenses to the country's telecoms operators. The move follows the finalization and approval of regulations concerning the allocation and licensing of radio frequency spectrum, as well as network interconnection, on 24 September. According to the

regulator's website, it has so far awarded official mobile spectrum licenses to Hormuud Telecom (3 November), Golis Telecommunications (23 November) and Telesom (23 November). Developing Telecoms cites a statement from Hormuud as saying that it was allocated spectrum

in the 700MHz, 800MHz, 900MHz, 1800MHz, 2100MHz, 2300MHz, 2600MHz and 3.5GHz bands, although the operator did not state how much it paid for the frequencies.

(November 30, 2022) www.commsupdate.com



South Korea

The Ministry of Science and ICT (MSIT) has announced it is cancelling the spectrum licenses in the 28GHz band which had previously been awarded to KT Corp and LG Uplus, while also revealing it is shortening the duration of SK Telecom's concession for frequencies in the same band. With 28GHz spectrum having been secured by all three players at auction back in 2018 – alongside 3.5GHz spectrum allocations – all concessions contained a condition requiring that the operators construct at least 22,500 base stations using the latter band and 15,000 using the former band within three years. However, the MSIT has now said that following an inspection of the trio's network it has determined that, although the target for construction in the 3.5GHz band had been achieved,

the cellcos had fallen far short of the requirements in the 28GHz band. According to the MSIT, with both KT and LG Uplus having scored fewer than 30 points in its inspection, it was cancelling their respective spectrum allocations in line with the terms outlined in the initial spectrum award announcement. Meanwhile, SKT has been given a temporary reprieve after narrowly scoring above a 30-point threshold – it scored 30.5 points, compared to 28.9 and 27.3 for LG Uplus and KT, respectively. As a result, SKT's concession will remain valid until 31 May 2023, but should it fail to have achieved the mandated rollout target for 28GHz base stations by that date, the MSIT has confirmed its license will also be cancelled. (November 17, 2022) www.commsupdate.com



Spain

The Ministry of Economic Affairs and Digital Transformation (Ministerio de Asuntos Economicos y Transformacion Digital) has confirmed that the auction of 26GHz band spectrum suitable for 5G services will commence on 21 December 2022, with four telecoms operators pre-selected to bid. The four companies – Telefonica Espana (Movistar), Vodafone Spain, Orange Espana and Valladolid-based Globe Operator Telecom SI – will bid for the national concessions on offer which each have a reserve of EUR4 million (USD4.24 million). In a press release, the Ministry noted that the tender for 26GHz band frequencies forms a cornerstone of the country's recovery plan ('Plan de Recuperacion') it committed to in H2 2022 to foster the development of 5G technology. The first round of bidding will begin on 21 December, once the application submission and evaluation period has ended (on 20 December), and will see a total of 2,400MHz, divided into 200MHz blocks, up for sale. The concessions will be distributed in twelve national concessions in the 25.10GHz-27.50GHz band, along with 38 regional concessions in the 24.70GHz-25.10GHz band (two blocks of 200MHz in each of the autonomous communities and cities). All licenses will have a duration of 20 years, extendable for an additional

20-year period. 'The concessions are in accordance with the technical specifications established by the European Commission, in relation to the harmonization of the 24.25GHz-27.5GHz frequency band for terrestrial systems capable of providing wireless broadband electronic communications services in the Union,' the Ministry said. (December 21, 2022) www.commsupdate.com

The Ministry of Economic Affairs and Digital Transformation, acting via the Secretary of State for Telecommunications and Digital Infrastructures, has established bidding conditions ahead of its planned auction of 5G-suitable 26GHz spectrum. The auction will comprise twelve national 200MHz concessions in the 25.10GHz-27.50GHz range, alongside 38 regional concessions in the 24.70GHz-25.10GHz range. The starting price for each national concession has been set at EUR4 million (USD4 million), while the prices of regional concessions will be proportional to the population of the autonomous community or city under consideration. All licenses will have a duration of 20 years, extendable for an additional 20-year period.

(November 11, 2022) www.commsupdate.com



Sweden

The Post and Telecom Agency (Post & Telestyrelsen, PTS) in Sweden is inviting applications for spectrum in the 3.7GHz band (3720MHz-3800MHz) from 1 January. The frequencies will be available on a regional basis to support industrial 5G and IoT services. Existing licensees in the 3760MHz-3800MHz range can apply to

extend their licenses to the full bandwidth, subject to availability. (December 14, 2022) www.commsupdate.com

The Swedish Post and Telecom Agency (Post & Telestyrelsen, PTS) has distributed its broadband support for 2022, with SEK1.245 billion (USD118

million) made available to fund rural network rollouts. The regulator says the funding covers 384 projects and 33,867 buildings in the targeted regions of Norrland, Svealand and Gotaland. 44% of the total subsidies

went to community associations set up to improve rural connectivity. PTS expects around SEK1.3 billion to be made available for similar projects in 2023.

(November 11, 2022) www.commsupdate.com



Switzerland

The Federal Supreme Court has upheld a ruling from the Administrative Court regarding Swisscom's fiber rollout. In December 2020 the Competition Commission (Wettbewerbskommission, WEKO) opened proceedings against Swisscom amidst concerns that its decision in February that year to migrate to a point-to-multipoint (P2MP) topology would restrict competition by preventing other telcos from gaining physical access to Layer 1 infrastructure. As part of its investigation, WEKO imposed precautionary measures on the operator, barring it from arranging its fiber network in a way that would restrict access to its competitors. The Federal Administrative Court rejected Swisscom's subsequent appeal against the measures in September 2021 and confirmed WEKO's precautionary measures.

The apex court has now upheld that ruling, stating that the decision was not arbitrary. For its part, Swisscom issued a statement on the matter, noting that it had decided in October 2022 to install the majority of fiber-to-the-home (FTTH) lines using a point-to-point (P2P) architecture and to convert some existing P2MP connections to P2P. The state-owned provider added that the P2MP system allows for a faster buildout and WEKO's intervention had prevented it from putting into operation or marketing lines using this topology. Swisscom claimed that 500,000 connections were affected by the order. Swisscom went on to say that it offers all of its competitor's non-discriminatory access to its networks under regulated or commercially agreed conditions. (November 30, 2022) www.commsupdate.com



Tanzania

The Tanzania Communications Regulatory Authority (TCRA) has announced that Starlink, the satellite internet service of SpaceX, has applied for a license to operate high speed, low latency satellite broadband services in Tanzania. According to The Citizen, Starlink

aims to launch in the country during the first quarter of 2023, subject to regulatory approval. Starlink's low orbit satellites are designed to offer high speed, low latency broadband internet in remote and rural locations across the globe. (November 28, 2022) www.commsupdate.com



Uganda

The government of Uganda has transferred the assets of Uganda Telecom Limited (UTL) to the state-owned company Uganda Telecommunications Corporation Limited (UTCL). UTCL is 60% owned by the Ministry of Finance, Planning and Economic Development and 40% by the Ministry of ICT and National Guidance. The firm was established in April 2021 when UTL went into administration, and in February this year signed an asset sale agreement to take over the business of UTL. With effect from 1 December all UTL employees will transfer

to UTCL. UTL was part-privatized in 2000 and in 2007 Libyan investment vehicle Libya Africa Portfolio Green Network (LAP GreenN) took control of a 69% interest in the telco. By 2017, however, UTL was struggling to stay afloat and the Ugandan government announced that it would take control of the firm in an effort to revive its fortunes. A report from PML Daily says the management of UTCL now plans to offer improved mobile money and broadband services to help turn the business around.

(November 21, 2022) www.commsupdate.com



United Kingdom

British telecoms regulator Ofcom has announced that it has been notified of new fibre-to-the-premises (FTTP) pricing arrangements – known as 'Equinox 2' – that Openreach intends to put in place from 1 April 2023. Announcing the development, the watchdog noted that under its wholesale fixed telecoms market review rules, Openreach – the network unit of BT Group – is required to notify it of certain offers 90 days before they come into effect. This requirement, Ofcom claims, allows it and the wider industry to assess the offer, with the regulator where necessary having the power to intervene to prevent such terms being introduced.

According to Ofcom, it will now consider whether the notified offer raises competition concerns requiring intervention and reach a provisional view. It has said it expects to publish a consultation on this provisional view by early February, to which stakeholders will have 30 days to respond. For its part, Openreach has claimed that Equinox 2 will amend and supplement its original 'Equinox Offer' (the pricing schedule which became effective from 1 October 2021) by introducing new rental and connection discounts and certain new terms and conditions. According to the network operator: 'In particular, Equinox 2 will provide additional commercial

incentives to Communications Providers (CPs) in order to encourage the adoption of GEA-FTTP through the migration of existing copper end customers to GEA-FTTP.' (December 15, 2022) www.commsupdate.com

British communications regulator Ofcom has announced the launch of an industry-wide enforcement program into whether in-contract price rises were laid down clearly enough by operators before customers signed up. In a press release, Ofcom announced that, having analyzed customer complaints and other preliminary evidence, it was concerned that consumers who took out contracts between 1 March 2021 and 16 June 2022 may not have been provided with sufficiently clear information about in-contract price rises, which are usually applied in March or April each year. As per the regulator's rules during that period, if a provider included potential future price rises in the terms of a contract, these were required to be set out prominently and transparently at the point of sale. If it were the case that customer had not agreed to those terms when signing up – because they had not been made sufficiently prominent and transparent – providers should have notified them of the price increase and offered them a right to exit penalty-free. Ofcom has said it is now investigating 'what happened in practice', while noting it plans to collect additional information from a range of service providers to assess the steps they have taken to ensure these terms are prominent and transparent. Should the watchdog identify specific issues with providers complying with our rules, it may launch separate investigations into individual firms. Commenting on the matter, Lindsey Fussell, Ofcom's Networks and Communications Group Director, said: 'As millions of people are having to deal with rising household bills, it is more important than ever that telecoms companies don't shirk their responsibilities and keep customers fully informed about what they are signing up to ... It's vital that people are told clearly upfront about any future price rises they will face while

they are in contract, and we're investigating to check whether this happened in practice.'

(December 2, 2022) www.commsupdate.com

The communications regulator Ofcom opened an investigation into whether terms around in-contract price rises had been communicated clearly enough to consumers by mobile and fixed operators prior to sign-up. After analyzing complaints and other preliminary evidence, the regulator stated it had concerns customers who took out plans between the start of March 2021 and 16 June 2022 may not have been provided with sufficiently-clear information. Ofcom's investigation covers the above period, which ends the day before new regulations on the matter came into force. At the time covered by the probe, Ofcom noted service providers were required to "set out" any potential future price rises in contracts "prominently and transparently at the point of sale". "If the customer hadn't agreed to those terms when signing up, because they hadn't been made sufficiently prominent and transparent, providers should have notified them of the price increase and offered them a right to exit penalty-free." Ofcom noted it could subsequently launch separate investigations into specific providers if issues with them were found.

(December 1, 2022) www.mobileworldlive.com

Ofcom's Content Board is a committee of the main Ofcom Board. It has delegated, advisory responsibility for a wide range of content issues, including the regulation of television, radio and video-on-demand quality and standards. The Content Board provides senior editorial and content experience to Ofcom. It is made up of experts from a range of commercial, media and telecoms backgrounds, including newspapers, Channel 4, Sky, tech platforms and broadcasting. Maria will to Ofcom the interests and opinions of people living in Northern Ireland. She will join Ofcom's Content Board on a three-year term, beginning on 21 November 2022. (November 21, 2022) www.ofcom.org.uk



United States

The Federal Communications Commission's (FCC's) ability to auction spectrum is up for renewal on 16 December 2022, following a temporary postponement earlier this year. According to a recent report from the Congressional Research Service, members of Congress are understood to be debating the duration of a future extension and the best legislative vehicle for the extension. This may take the form of a standalone bill, an annual appropriation bill, or some other vehicle. Members are also continuing to discuss the development of a comprehensive spectrum package that would include a further extension among other provisions. Back in 1993 Congress authorized the FCC to use competitive bidding (i.e. auctions) to grant licenses for rights to use specific frequencies for

commercial mobile communications. That authority was originally due to expire on 30 September 1998, but Congress has extended it several times. The most recent long-term extension in 2012 – which ran until 30 September 2022 – was granted as part of the 'Middle Class Tax Relief and Job Creation Act of 2012'. On 30 September 2022, Congress passed – and President Biden signed – a continuing resolution that extended the FCC's spectrum auction authority until 16 December 2022. That extension allowed the FCC to complete licensing and other activities related to its 2.5GHz band auction ('Auction 108'). (December 1, 2022) www.commsupdate.com

US regulator the Federal Communications Commission (FCC) released updated broadband maps showing

where 5G and internet services are accessible in a move to provide users with more accurate information about pricing, speeds and availability. While the latest maps provide the most detailed information to date, the FCC acknowledged they are a work in progress. Previous maps displayed areas where consumers supposedly could get access, despite some not actually being covered by service providers. The maps display location-specific information about the broadband services available instead of relying on census block level data previously collected. The updates also offer detail on data rates by street. There will also be a key role for the updated maps in government broadband funding projects to bridge the digital divide in rural and underserved areas. "Our pre-production draft maps are a first step in a long-term effort to continuously improve our data as consumers, providers and others share information with us," FCC chair Jessica Rosenworcel

stated. She added improving the accuracy of broadband coverage information will enable local and national government to "better work together to ensure no one is left on the wrong side of the digital divide". The FCC is required to update mobile and fixed maps as part of the Broadband DATA Act, with funding for the effort coming from a \$1.2 trillion government pot. It plans to update the details with new information from service providers around every six months, with consumers able to report if fixed-line services shown are not available. Map users will also be able correct and add location information. The draft maps will also allow users to view the wireless coverage reported by mobile operators. The FCC also launched an updated version of its mobile network performance app, enabling consumers to challenge operators' claimed coverage.

(November 21, 2022) www.mobileworldlive.com



Virgin Islands

The Telecommunications Regulatory Commission (TRC) has announced the renewal of all four unitary licenses in the British Virgin Islands (BVI). The four renewed licenses were issued to BVI Cable TV, Cable & Wireless (BVI), Caribbean Cellular Telephone and Digicel (BVI). The concessions were first issued in 2007, signaling the start of liberalization in the BVI. The unitary licenses are valid for 15 years apiece (starting 12 December 2022), but subject to five-year compliance checks. All companies offer mobile connectivity – with the notable exception of BVI Cable TV. In June 2017

it was announced that the cableco was to be merged with CCT and it has essentially disappeared from view. Given the year-long consultancy period that preceded the license renewal, BVI Cable TV is something of a surprise inclusion on the new unitary license list. Indeed, as per TRC paperwork, the renewal process 'involved in-depth review of applications, allowance for public comments, public hearings, compliance evaluations, and the revision of the terms and condition of the unitary licenses.

(December 20, 2022) www.commsupdate.com



Zambia

The Zambia Information and Communication Technology Authority (ZICTA) has disclosed that the country's fourth mobile network operator Beeline Telecom will launch commercial LTE-based services by the end of January 2023, Broadcast Media Africa reports. ZICTA Manager of Legal and Regulatory Affairs Banji Michelo was quoted as saying: 'We granted an extension [from the previous launch target date of 30 June 2022] because the company was unable to commence operations due to challenges with the procurement process owing to COVID-19. But now the company will launch operations on January 31, 2023.' The regulator also asserted that the locally-owned new

entrant possesses sufficient financial capability to raise levels of competition in the Zambian telecoms sector. Beeline Telecom – which won its operating license in February 2021 – has claimed it will invest USD400 million and create more than 450 direct jobs via its mobile service launch. Zambia had approximately 19.2 million mobile subscriptions at end-September 2022, giving a cellular population penetration rate of about 95%, with Airtel currently leading in terms of subscription volume market share (nearly 42%), closely followed by MTN (around 39%), with Zamtel accounting for the remainder.

(December 12, 2022) www.commsupdate.com



Zimbabwe

The Postal and Telecommunications Regulatory Authority of Zimbabwe (Potraz) has said internet and data usage in the country has been consistently increasing owing to a more digitalized economy. This development comes at a time the internet penetration rate is expected to rise to 75,4 percent by 2025, as the Government moves to ensure improved access and usage

of ICTs as part of the National Development Strategy 1 (NDS1). According to the sector performance report for the third quarter 2022, Potraz Director General Dr. Gift Machengete said the postal and telecommunication sector has continued to grow as more services move to the digital space, contributing to increased demand and consumption of telecommunication services. "Internet

and data usage has been consistently increasing owing to a more digitalized economy, with mobile internet data traffic totaling 32 473,1 terabytes in the third quarter of 2022, representing a 26.1 percent growth from 25 755,9 terabytes recorded in the previous quarter.” He said the postal and telecommunication sector is expected to grow exponentially with increased adoption of ICTs, operator investment and innovation efforts, as well as the Authority’s efforts to close the digital divide. Dr. Machengete said the sector will continue enabling other sectors as envisioned in Government’s NDS1. He added: “Prioritization of the sector in terms of Government expenditure, power availability, protection against vandalism, resource mobilization, foreign currency availability among other issues is pertinent.” In terms of the total active mobile subscriptions, Dr. Machengete said it increased by four percent to reach 14,5 million up from 14 million, hence, the mobile penetration rate increased by 3,6 percent to reach 95,9 percent from 92,3 percent.” He said the total active internet and data subscriptions increased by 4,3 percent, while internet penetration rate increased by 2,6 percent to reach 63,9 percent from 61,3 percent in line with the growth in active subscriptions. Dr. Machengete added: “Total active fixed telephone lines increased by 2,8 percent. Hence, the fixed tele-density increased by 0,06 percent to reach 1,92 percent from 1,86 percent. Used incoming international internet bandwidth capacity also increased by 4,3 percent.” He said mobile voice traffic totaled 3,08 billion minutes and this represented a considerable 31,2 percent growth from 2,35 billion minutes recorded in the second quarter of 2022. In terms of volumes, he said total postal and courier volumes increased by 4,5 percent to record 547 125 items from 523 342 items recorded in the second quarter of 2022. Dr. Machengete said: “The growth in total mail volumes experienced in the quarter under review comes after consecutive periods of persistent contraction. The growth could be a sign of recovery for the postal and courier sector.” He said total mobile operator revenues grew by 103,9 percent to record ZWL\$61,39 billion from ZWL\$30,1 billion, while Internet Access Provider (IAP) revenues grew by 104,8 percent to record ZWL\$30,86 billion from ZWL\$15,07 billion. Dr. Machengete said total revenue

generated by the postal and courier sector increased by 49,4 percent to record ZWL\$3,9 billion from ZWL\$2,6 billion. Despite revenue growth, he said: “Total mobile operator operating costs grew by 97,1 percent to record ZWL\$48,6 billion from ZWL\$24,7 billion, while operating costs for IAPs grew by 52,9 percent to record ZWL\$18,25 billion from ZWL\$11,93 billion. The postal and courier sector operating costs increased by 40,5 percent to record ZWL\$2,9 billion from ZWL\$2,08 billion. The increase in operating costs was less than revenue growth, across all markets.” Meanwhile, in 2020, the internet penetration rate in Zimbabwe was 59,1 percent and the Government intends ramp up the penetration rate by over 15 percent in the next two years. Further, the mobile penetration rate is expected to grow from 94,2 percent to 100 percent by 2025. The Government has challenged the postal and telecommunication sector to contribute to the growth trajectory by expanding their networks to include the under-served areas and bringing in international bandwidth to achieve the targeted internet penetration rate.

(December 13, 2022) www.samenacouncil.org

The Postal and Telecommunications Regulatory Authority of Zimbabwe (POTRAZ) has awarded an MVNO licence to Dolphin Telecoms, which aims to become the country’s first successful reseller after other attempts to launch an MVNO failed to get off the ground. A report from Zimbabwe Independent says Dolphin has secured a wholesale arrangement with one of Zimbabwe’s three mobile network operators (MNOs), though the identity of the partner was not published. According to the report, Dolphin’s service will be available across ‘a large coverage area, built on the partner’s extensive backbone’ and a commercial launch is planned for later this year. Dolphin says it has so far invested USD15 million in its Zimbabwe launch and it aims to offer users a highly customizable portfolio of service bundles, while it will also target the financial services sector. Telecoms providers in Zimbabwe are current struggling to stay afloat amidst the country’s ongoing economic crisis.

(November 1, 2022) www.commsupdate.com

Unleash your connectivity with Equinix Internet Exchange[®]



Available In Mobily Jeddah data center



EQUINIX



0100 100100 100100
1001 001 1001 001
100 100100 000100
11 0110 01 1010
0110 10 10 100

BUSINESS
NETWORKS
SOCIAL NETWORK
TECHNOLOGY
HEALTH
CREATIVE
FINANCE
LIFE SCIENCE
CONSUMER
ECONOMY

110 1011 000110
10 11 10010 001010 1101
1101 001 001010 01
01 00101 1010
100 1011 1101 01 011 1